



Northville Record



Your hometown newspaper serving Northville for 136 years

Thursday, June 29, 2006

northvillerecord.com

50c

Look inside for your **GREEN SHEET** Classifieds
Greensheetclassifieds.com

What you **NEED TO KNOW**

Town Hall Meeting
Tonight Northville residents are invited to attend a public town hall meeting where details about two August millage proposals will be discussed. The 7 p.m. meeting will be held at Township hall and will include a Power Point presentation and details about the public safety and shared services millages slated for the Aug. 8 election. "I want people to attend ... so they can see for themselves where the money will be spent," said Mark Abbo, township supervisor.

What's Going On?
In town See what's happening locally this weekend by checking out Northville's official events calendar. Page 16A.

Library Board
The filing deadline for candidates interested in serving on the Board of Trustees of the Northville District Library is July 20. The seven-trustee board, responsible for overseeing the operation, policy-making and resource allocation of the Northville District Library, is expected to have four available trustee positions at the end of the year. The library district includes the City of Northville and Northville Township. City and township residents are eligible.

Record Sections!
Get to know area businessmen in today's special section!

INDEX

Classifieds.....	3D
Opinion.....	14A
It's Always Something.....	13A
Letters.....	14A
Police Briefs.....	6A
Sports.....	1B
What's Going On?.....	16A

CONTACT US

- Classifieds: (888) 999-1288
- Newsroom: (248) 349-1700
- Home Delivery: (888) 840-4809



Postal Information: (888) 999-1288
HONG & SONS BK BINDERY
PO BOX 162
SPRINGPORT MI 49284-0162

COLLIGAN RETIRES

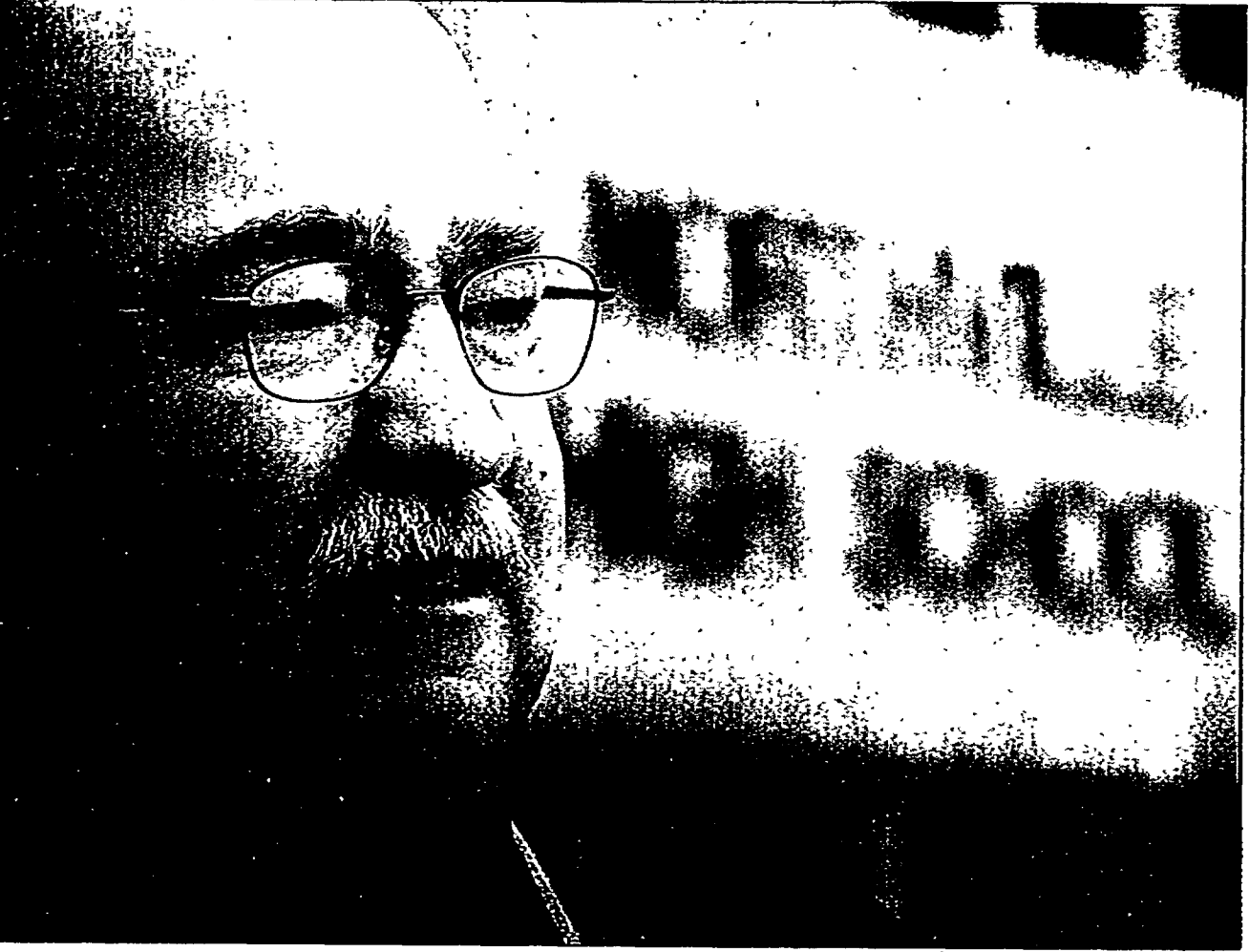

Principal Dennis Colligan, who officially retires tomorrow, stands outside his second home: Northville High School.

LEAVING HOME

After 32 years, Dennis Colligan says good-bye to Northville Public Schools

By Victoria Mitchell
RECORD STAFF WRITER

You can hear Dennis Colligan smile when he talks. Incessantly jovial, he could say you aren't graduating, and you'd thank him. Colligan's not the archetype of a leader of Northville's largest school. Then again, wielding tyrannical rule has never been his style. So when Colligan announced in April he would retire after 32 years with Northville Public Schools, the district gave a collective sigh before trying to imagine how to say goodbye. And how to replace him. Tomorrow, Colligan will place the final box top on the contents of his desk drawer, walk down the expansive hallway and exit through the doors one last time as principal.

Going out on top
There are two ways to make an exit: on top, or after the fall. "I always thought about retirement coming at a time when you still felt good about yourself and good about your position," Colligan said, who's seen his share of people come and go, noticing what frustrated them. He didn't

want to reach that point. Colligan, 57, said he is going out on top. "I wanted to walk out feeling pretty good about things," he said. "And I feel really good about the position the high school is in right now and the time was good."

Hired:
New principal Robert Watson was named Tuesday as the new high school principal. Page 10A.

Nearly 2,100 high school students, the largest to date, have exceeded federal and state academic standards, collected record-breaking numbers of awards and trophies and participated in groups and clubs. School officials said the graduating class of 2006 earned nearly \$7.5 million in scholarship dollars and 70 percent of the class graduated with honors. State championships, 23 National Merit Scholarship Program honorees, 14 division titles in the Western Lakes Activities Association and a student-run blood drive responsible for collecting 280 pints of blood spell success to Colligan.

continued on Page 5A



Retiring Northville High School principal Dennis Colligan laughs while students Shawn Spire, left, and junior Brett Spencer, right, acknowledge what many have long felt: "He's the man!"

Cooke heads for heated discussion

But reclaiming former middle school would come with notable human costs

The second installment in a series regarding Northville Public Schools growth talks.

By Victoria Mitchell
RECORD STAFF WRITER

Marie Morrison can't imagine her world without Cooke School. She feels so strongly, she penned a letter to Northville Board of Education members letting them know how much the school and the district's participation means to her and Elizabeth — her daughter born with Down Syndrome. The Northville mom said she compares the district to a loving, caring family looking out for her daughter's best interest.

"We'd lose something that is valuable."

Joan Wadsworth
Treasurer, Northville Public Schools
Board of Education

"I hope ... you (the board members) will be able to understand just what Northville Public Schools, Cooke School means to Elizabeth and me — what



Cooke School principal, Marilyn Bachorik, right, chats with student Danielle Malaniak.

Get busy

Geared up for downtown makeover, officials seek volunteers

By Maureen Johnston
RECORD STAFF WRITER

Frequent downtown concert fans, Jerry and Terry Mittman have long thought there should be more grass around the gazebo. Jim Long wants to talk about whether Mary Alexander Court should become a two-way street. Carolann Ayers wishes parking rules were clearly posted. On Monday night, the Northville City Council accepted an inch-thick downtown strategic plan from Ann Arbor-based consultant Beckett and Raeder encompassing those ideas. Now city leaders are turning to their constituents with one question: What's your passion?

Sign me up:
Get involved

Proven strategy
Ten years ago, the community's rallying point.

Fort Griswold, grew from a commitment by grassroots experts and local individuals. The revitalization of downtown is Northville's new playscape, where design ideals are about to collide with existing conditions and regulations, challenging leaders to make the best use of local talent and investor interest. "The Northville community has a long history of volunteering," said Jerry Mittman, a former councilman and perennial volunteer. "Once the key elements of the downtown strategic plan are identified and the implementation

continued on Page 7A

PARADE

Northville grad will make 'Stealth' flyover Tuesday

By Maureen Johnston
RECORD STAFF WRITER

Flying a Stealth jet while your whole hometown is watching: How cool is that? U.S. Air Force Capt. Tim "Maddog" Smith, a 1995 Northville High School graduate, will have better than a bird's-eye view for the Independence Day parade Tuesday. Last year, Smith stood along a downtown sidewalk for the parade. Next week, he'll be one of the pilots who will swoosh over the thousands of spectators lining Main Street for the 10 a.m. community celebration. "This is a once in a lifetime opportunity in which I am proud to showcase the USAF Stealth Fighter for such a patriotic event and crowd," Smith e-mailed from

continued on Page 3A

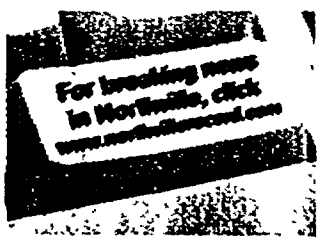

TOWN & COUNTRY EYECARE
Thanks for Voting us "Best Eyecare"
Novi Road at Nine Mile • 248-347-7800 • www.tceyecare.com



MODEL YEAR CLEARANCE

0% DRIVE \$0
 APR + Until 2007
 Financing Including **EB5 FUEL CAPABLE**

OR LEASE ONE OF THESE VEHICLES

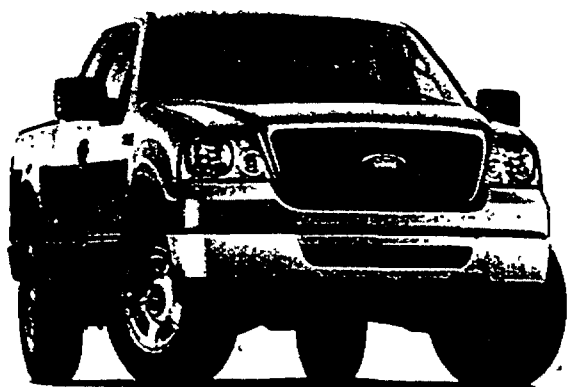

Eligible Ford Employees can Lease a 2006 F-150 SC 4X4 XLT

For as low as **\$159** A month(1) with a 24 month low mileage Red Carpet Lease

With \$1,954 customer cash due at signing.

Includes acquisition fee; security deposit waived.** Excludes tax, title and license fee. Cash due is after \$3,500 cash back.



Eligible Ford Employees can Lease a 2006 Explorer XLT 4x4

For as low as **\$199** A month(1) with a 24 month low mileage Red Carpet Lease

With \$2,919 customer cash due at signing.

Includes acquisition fee; waived security deposit.** Excludes tax, title and license fee. Cash due is after \$4,000 cash back.

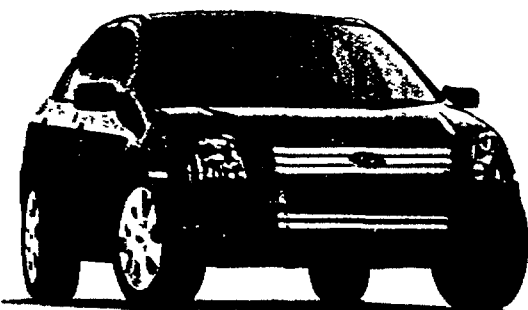

Eligible Ford Employees can Lease a 2006 Ford Fusion SE

For as low as **\$199** A month(1) with a 24 month low mileage Red Carpet Lease

With \$2,134 customer cash due at signing.

Includes acquisition fee; security deposit waived.** Excludes tax, title and license fee. Cash due is after \$1,000 cash back



Eligible Ford Employees can Lease a 2006 Ford Escape XLT FWD

For as low as **\$199** A month(1) with a 36 month low mileage Red Carpet Lease

With \$2,919 customer cash due at signing.

Includes acquisition fee and security deposit. Excludes tax, title and license fee. Cash due is after \$1,500 cash back.



BOLDMOVES

Your Suburban Ford Dealers

fordvehicles.com

(1) Not all buyers will qualify for Ford Credit Red Carpet Lease. Payments may vary. All payment examples are for Current Ford Employees and eligible family member Lessees. Residency restrictions apply. For special lease terms, RCL Cash, AZ Plan Cash and FMOC bonus cash, take new retail delivery from dealer stock by 7/5/2006. Supplies are limited, not all dealers will have all featured models. See dealer for complete details. Customers must finance through Ford Credit. **Not all buyers qualify for Ford Credit limited term financing. Not available on Ford GT, Mustang GT. Receive maximum \$1,100 debit card amount varies by model. Not available on Ford GT, Mustang GT, F-350 & E-350 models and higher. Take new retail delivery from dealer stock by 7/31/06. See dealer for qualifications and complete details. *Security deposit waived.

HINES PARK FORD

I-96 at Milford Rd.
 248-437-6700

OPEN SATURDAYS

Behind the scenes: Northville's annual patriotic salute taking shape

Flower power helps keep Fourth effort afloat

By Maureen Johnston
RECORD STAFF WRITER

Laura Droze makes paper napkin flowers in her sleep.

In her sixth year as float coordinator for Our Lady of Victory Church, the Northville resident targeted a goal of 15,000 white, yellow, black and green pods of color. On Monday, she and her volunteer corps will finish securing flower-studded chicken wire and wood forms in place on a mobile platform.

Rain or shine, the church's float will be ready to roll in time for Tuesday's 10 a.m. start of Northville's Independence Day parade, Droze said.

"This next week will be our crunch week," she said. "We'll be there July 3 until it's done."

"We'll pray for nice weather," she added with a laugh.

Mercy Hospital.

Festivities will begin with the Sweet Adelines singing patriotic tunes in front of city hall prior to the parade, followed by the National Anthem.

Foundation president Shari Peters said she added many children's characters to the parade cast so the youngest spectators will have a chance to wave to Paws from the Detroit Tigers, Louie the Lighting Bug, the Hamburglar, Shooter from the Whalers, the Big Boy and others.

The reward of teamwork

Droze hasn't stood by the parade sidelines for several years. She said the march down Main Street alongside the church's float is a reward for the months of teamwork she's supervised.

"You can just see the pride and hear them, 'I made flowers for that,'" Droze said. "It's a nice lit-

tle community social gathering for them."

When the float is parked in the church lot after the parade, volunteers take their photograph near the finished project, Droze said. The mother of four recruits her husband and children early on.

"We do it at home watching TV, one will be cutting wire, one will be folding."

Creating flowers joins 9-year-olds to 90-year-olds toward the same purpose, Droze said.

"There's not many projects with that span that you can say, 'We worked on this together,'" she said. "It's about giving back to the community."

"This is my one big project for the church. It's time consuming, but it's good to see people socializing."

Maureen Johnston can be reached at (248) 349-1700, ext. 103, or mjohnston@gannett.com.



Submitted Photo

Capt. Tim "Maddog" Smith, a 1995 Northville High School graduate.

continued from 1A

Holloman Air Force Base in New Mexico. "Besides, how many people get to fly a \$50 million fighter jet over their hometown!"

"It will be great!"

Once in a lifetime

The military fly-over, always a show stopper while crowds are watching the annual patriotic procession, landed in Smith's lap by chance.

"It was completely random that our squadron (9th Fighter Squadron) was assigned this flyby," Smith wrote. Headquarters Air Combat Command has an air show office that processes all aerial event requests, he explained, handing them off to individual bases with the type of jet for the event.

Smith said when he saw the air show schedule about a month ago, he volunteered for the Northville event. A seven-year Air Force veteran, he has more than 1,200 flight hours in fighter aircraft, including the F-16 and F-117.

"This is a once in a lifetime opportunity in which I am proud to showcase the USAF Stealth Fighter for such a patriotic event and crowd."

Tim "Maddog" Smith
Captain, U.S. Air Force, 1995 Northville High School graduate

Veteran flyer

Smith has been stationed at five different bases, including Shaw Air Force Base in South Carolina, Laughlin and Kelly bases in Texas, Eielson Air Force Base in Arkansas and currently at Holloman.

He's been deployed all over the Pacific theater, serving in Korea, Okinawa, Singapore, and Guam. He's also flown in support of Operation Nobel Eagle and Enduring Freedom.

On Tuesday, his in-laws, Phyllis and Anthony Heckemeyer, will be on Main Street below. His wife, Katrina, another 1995 Northville High School graduate, and their three children will be back on the base.

Maureen Johnston can be reached at (248) 349-1700, ext. 103, or via e-mail at mjohnston@gannett.com.

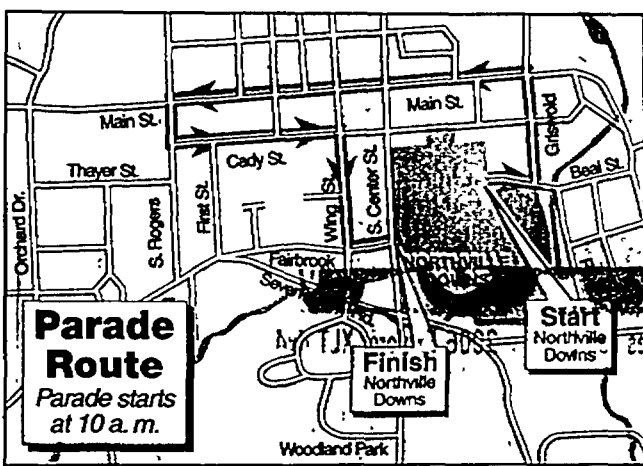

SOURCE: Northville Community Foundation



Photo by JOHN HEIDER/Northville Record

Claire Naughton, 12, right, helps make thousands of paper flowers that will adorn the Our Lady of Victory Fourth of July Parade float.

"You can just see the pride and hear them, 'I made flowers for that'"

Laura Droze
Float Coordinator, Our Lady of Victory church

Family Law with your future in mind

Peg Frank Schweitzer
Attorney and Counselor at Law
Ann Arbor W Bloomfield
734-214-7686 248-406-5015
www.pegschweitzer.com

Traditional & Collaborative Methods for Resolution

BURTON & SONS INC.
PLUMBING HEATING
FAMILY OWNED & OPERATED FOR THREE GENERATIONS
For FAST In-Home Service!
Call: 734-427-7777
See Our Website For Savings
www.BurtonAndSons.com

THE NORTHVILLE RECORD
Published Each Thursday
By The Northville Record
104 W. Main Street
Northville, Michigan 48167
Periodical
At Northville, Michigan

Subscription Rates:
Inside Counties \$26 one year home delivery. Outside Counties (in Michigan) are \$40 per year, prepaid. Out of state, \$50 per year.

The Northville Record is published by Federated Publications, Inc a wholly owned subsidiary of Gannett Co. Inc. Postmaster, send address changes to: The Northville Record, Post Office Box 470, Howell, MI 48844. POLICY STATEMENT: All advertising published in The Northville Record is subject to the conditions stated in the applicable rate card, copies of which are available from the advertising department, The Northville Record, 104 W. Main Street, Northville, Michigan 48167. (248-349-1700). The Northville Record reserves the right not to accept an advertiser's order. The Northville Record ad-takers have no authority to bind this newspaper and only publication of an advertisement shall constitute final acceptance of the advertiser's order.

Publication Number USPS 3989-20

BUSCH'S
Fresh. Food. Ideas.

PRICES EFFECTIVE THROUGH SUNDAY, JULY 2, 2006

\$1.78 lb. FAMILY PACK CERTIFIED GROUND CHUCK

\$1.99 lb. FAMILY PACK FARM FRESH BONELESS, SKINLESS CHICKEN BREAST

99¢ BUSH'S BEST BAKED BEANS ALL VARIETIES 28 OZ.

\$1.79 lb. FRESH PACKED RED, RIPE STRAWBERRIES

HAPPY 4TH!

WWW.BUSCHS.COM HAVE A SAFE & HAPPY FOURTH OF JULY!

CIRCLE GOLD CHECKING WITH INTEREST
2.00% APY
ON CHECKING BALANCES

HOME EQUITY LOAN
6.59% APR
10-YEAR TERM

Charter One
Not your typical bank.®

High interest where you want it. Low where you need it.

To get Circle Gold Checking with Interest or a Home Equity Loan, visit any of our 124 Michigan branches, go to charterone.com or call 1-877-TOP-RATE.

Member FDIC. Checking balances mentioned above refer only to Circle Gold Checking with interest balances. Other financial institutions may charge for use of their ATMs. The \$20 monthly fee is waived with a combined relationship of \$20,000 Annual Percentage Yields (APYs): 2.00% APY for balances \$5,000 or greater, 2.00% APY for balances \$0-\$4,999. APYs accurate as of this publication date. APY on checking is variable and may change before or after account opening. Fees on deposit accounts may reduce earnings. Home Equity: 6.59% Annual Percentage Rate (APR) available for qualifying properties in MI, IN, OH with a loan-to-value (LTV) of 85% or less for loans of \$10,000-\$500,000. An LTV of 80% or less for loans of \$500,000-\$750,000 or an LTV of 75% or less for loans over \$750,000 with auto-deduction from Circle Checking™ and a 10-year term. Circle Checking Account with \$50 minimum opening balance required. An equity loan of \$10,000 with a 10-year term at 6.59% APR results in 120 monthly payments of \$114.01. Other rates and terms available. Rates and terms vary by property type, loan amount and LTV ratio. Offer subject to change without notice. 1- to 4 family owner-occupied properties only. Not available for homes currently for sale or intended to be sold within six months of closing. Property insurance required. Flood insurance may be required. Trust review fees ranging from \$85 to \$175 apply for properties held in trust. All accounts are subject to individual approval. See a banker for details. © Equal Housing Lender.

CLINIQUE free 7-piece bonus

WITH ANY CLINIQUE PURCHASE OF \$25 OR MORE, NOWHERE BUT LORD & TAYLOR



Your bonus

Includes:

- Dramatically Different Moisturizing Lotion
- New! Turnaround Concentrate Visible Skin Renewer
- Colour Surge Eyeshadow Palette
- Long Last Lipstick in Glow Bronze
- Lash Doubling Mascara in Black
- Floral Cosmetic Bag
- Mini Wristlet

Allergy tested. 100% fragrance free (with the exception of Clinique fragrance products).

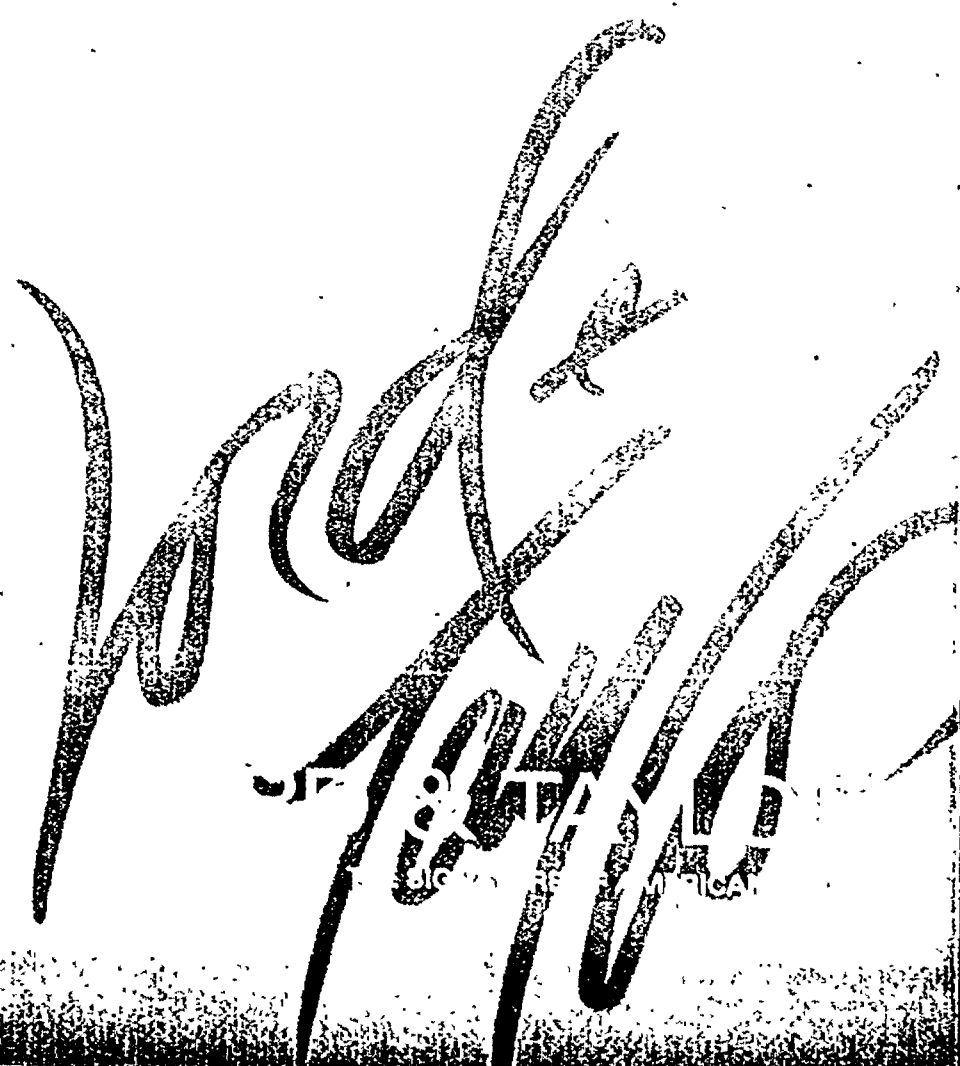

LEAVING HOME: Colligan retires

continued from Page 1A

A far cry

The successes Colligan experiences today differ dramatically from 35 years ago when he began his education career. In 1971, he accepted a special education teacher position at the Hawthorn Center.

But it was a 7 a.m.-3p.m. job, and Colligan wanted more. He wanted after-school football practices and the rush of cheering students through tight games.

Colligan accepted a special education teaching position with Northville Public Schools in 1974.

"I started really enjoying the after-teaching part of the position of education right away," he said. "That was a lot of fun and that was the start of my career," he said.

By 1983, when Northville Public Schools Assistant Superintendent for Administrative Services David Bolitho was principal of the high school, Colligan was already head football coach.

Later, Colligan became part-time, then full-time, athletic director before taking on the role as assistant principal and ultimately principal.

"Dennis has always exhibited the highest degree of professionalism possible," Bolitho said. "Always focusing on the welfare of his students, the high school and the district."

Triple hit

Colligan looks at his career in three different sections:

Back in the saddle:

■ He's back!

Dennis Colligan may be retiring from the principal's chair, but he's returning to the gridiron as a JV coach with friend Darrel Schumacher. Page 1B.

administrator for 32 years. I wasn't a teacher for 32 years. I was able to do three different things, and I think that really was healthy in my career."

Colligan remembers fondly his stint as athletic director.

"I was able to kind of work a hobby and work with all the athletes and break away from just the football element I was coaching at the time," he said.

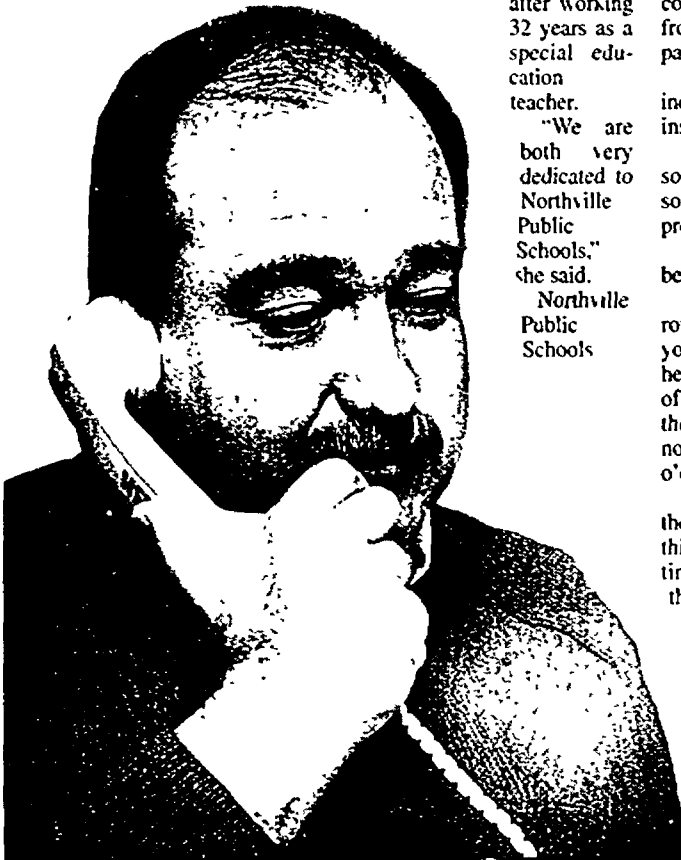

FAREWELL FRIEND

Over the years, I watched Dennis Colligan shake the hand of every graduate of Northville High School and call them by name as they approach. It takes a special person to know every student in a class of 500. Your relationship with students was really something special Dennis. Thanks for giving so much of yourself to this community.

— Casey Reason, Northville Public Schools Assistant Superintendent

Dennis, enjoy spending well deserved time with your family and know there are 35 years worth of students who have benefited greatly from your teaching, coaching, athletic directing and leadership as principal at NHS. As a board member, I always enjoyed listening to the personal comments you made to each graduate as they shook your hand after receiving their diploma. Many of the students greeted you with a big hug and thanked you for all you did to support them in their education. You're clearly a very positive influence in the lives of our students and will be missed. Warmest wishes.

— Karen Paclorek, President Northville Board of Education

WE WILL MISS YOU!

Dennis was an excellent mentor as I succeeded him as the athletic director for the Northville Public Schools. He always took the time to answer my questions and help me whenever necessary. He understood the complex issues of running an athletic department and his administrative support was greatly appreciated. Now that he is retiring I will need to get additional strokes on the golf course.

— Larry Taylor, Retired NPS Athletic Director

Dennis has been a tremendous leader of Northville High School. The students and staff respect and love what he brings to them daily in the form of stability, boundaries, and encouragement. He supports the efforts of kids far beyond the school day and can be found at a band concert just as readily as a football game. He leads with his heart and teaches by example. Dennis has given us the perfect mixture of administrative talent, empathy, wisdom, and a sincere respect for a community he loves, and that in turn, loves him.

— Shelia Brown, Northville High School Assistant Principal

I have had the privilege of working with Dennis for the last seven years (five as his assistant). Dennis has mentored me and helped me grow in my profession. He has given me invaluable advice as it relates to work as well as raising my own family. Though I am happy for his opportunity to retire at the top of his game, I am saddened to not see him every day.

— Rob Watson, Northville High School Assistant Principal

HAPPY RETIREMENT!

But in the early to mid 1990s his own children began competing athletically at Novi High School. Colligan knew he had difficult decision to make. He couldn't be a bleacher parent while serving as Northville's athletic director.

Family won. Colligan applied for a job opening as an assistant principal at the high school.

"I went into the assistant principal job around, I believe, 1995 and I was able to watch my kids compete at Novi and still fulfill the requirements of the assistant principalship here," he said.

All in the family

Joanne Colligan said it is no surprise her husband of 34 years changed career paths to relish his family.

"He is a devoted family man, always managing to find a balance between his family and career," she said.

The Colligans have three children, their youngest graduating from college this year.

The couple also had their first grandchild in January.

"Certainly a big change in our life is having a grandson to spoil and to pay some attention to and they are local so we can get down there and do a good job of spoiling him," Dennis said.

Joanne joins Dennis in retirement this year, leaving Amerman Elementary School in January after working 32 years as a special education teacher.

"We are both very dedicated to Northville Public Schools," he said.

Northville Public Schools



Northville High School principal Dennis Colligan has worked in Northville since 1974.

Superintendent Leonard Rezmierski said he has tremendous respect for both.

"Dennis and his family are a part of the fabric of Northville Public Schools," he said.

A new attitude

The sight of a Dunkin' Donuts coffee cup will likely be absent from the credenza in the principal's office after tomorrow.

A familiar morning drive, including a stop for coffee, will instantly vanish for Colligan.

"I do have routines, and I am somewhat predictable and maybe some cohorts would say I'm very predictable," Colligan said.

But finding a new routine will be something he will work at.

"Maybe get into a nice exercise routine that is hard to do when you are in the position I am in," he said. "Being able to take care of yourself a little better and read the morning paper. Sometimes now I read the paper at 10-11 o'clock at night."

"It would be nice to read it in the morning, and just catch up on things and get into some new routines. I'm looking forward to that."

Another daily constant he will miss: his assistant Cindy Wolso.

For 12 years, she has greeted him with a smile.

"Cindy has just been a pillar of strength in running the administra-

"I think the community, the students, the parents and the staff have given me much more than I have given them, and I am really appreciative of being able to spend my career here."

Dennis Colligan
Principal, Northville High School

Colligan said he's experienced extreme satisfaction throughout his career with the district.

"I think it was a great opportunity for me every step of the way, being able to spend 32 years in a school district like Northville," he said.

"I can't imagine how it is for other districts because I am pretty spoiled being here and there will always be a special place."

"I think the community, the students, the parents and the staff have given me much more than I have given them, and I am really appreciative of being able to spend my career here."

Colligan said he's experienced extreme satisfaction throughout his career with the district.

"I think it was a great opportunity for me every step of the way, being able to spend 32 years in a school district like Northville," he said.

"I can't imagine how it is for other districts because I am pretty spoiled being here and there will always be a special place."

"I think the community, the students, the parents and the staff have given me much more than I have given them, and I am really appreciative of being able to spend my career here."

"I think the community, the students, the parents and the staff have given me much more than I have given them, and I am really appreciative of being able to spend my career here."

"I think the community, the students, the parents and the staff have given me much more than I have given them, and I am really appreciative of being able to spend my career here."

"I think the community, the students, the parents and the staff have given me much more than I have given them, and I am really appreciative of being able to spend my career here."

"I think the community, the students, the parents and the staff have given me much more than I have given them, and I am really appreciative of being able to spend my career here."

"I think the community, the students, the parents and the staff have given me much more than I have given them, and I am really appreciative of being able to spend my career here."

"I think the community, the students, the parents and the staff have given me much more than I have given them, and I am really appreciative of being able to spend my career here."

"I think the community, the students, the parents and the staff have given me much more than I have given them, and I am really appreciative of being able to spend my career here."

"I think the community, the students, the parents and the staff have given me much more than I have given them, and I am really appreciative of being able to spend my career here."

"I think the community, the students, the parents and the staff have given me much more than I have given them, and I am really appreciative of being able to spend my career here."

"I think the community, the students, the parents and the staff have given me much more than I have given them, and I am really appreciative of being able to spend my career here."

"I think the community, the students, the parents and the staff have given me much more than I have given them, and I am really appreciative of being able to spend my career here."

"I think the community, the students, the parents and the staff have given me much more than I have given them, and I am really appreciative of being able to spend my career here."

"I think the community, the students, the parents and the staff have given me much more than I have given them, and I am really appreciative of being able to spend my career here."

"I think the community, the students, the parents and the staff have given me much more than I have given them, and I am really appreciative of being able to spend my career here."

"I think the community, the students, the parents and the staff have given me much more than I have given them, and I am really appreciative of being able to spend my career here."

"I think the community, the students, the parents and the staff have given me much more than I have given them, and I am really appreciative of being able to spend my career here."

"I think the community, the students, the parents and the staff have given me much more than I have given them, and I am really appreciative of being able to spend my career here."

"I think the community, the students, the parents and the staff have given me much more than I have given them, and I am really appreciative of being able to spend my career here."

"I think the community, the students, the parents and the staff have given me much more than I have given them, and I am really appreciative of being able to spend my career here."

"I think the community, the students, the parents and the staff have given me much more than I have given them, and I am really appreciative of being able to spend my career here."

"I think the community, the students, the parents and the staff have given me much more than I have given them, and I am really appreciative of being able to spend my career here."

"I think the community, the students, the parents and the staff have given me much more than I have given them, and I am really appreciative of being able to spend my career here."

"I think the community, the students, the parents and the staff have given me much more than I have given them, and I am really appreciative of being able to spend my career here."

"I think the community, the students, the parents and the staff have given me much more than I have given them, and I am really appreciative of being able to spend my career here."

"I think the community, the students, the parents and the staff have given me much more than I have given them, and I am really appreciative of being able to spend my career here."

"I think the community, the students, the parents and the staff have given me much more than I have given them, and I am really appreciative of being able to spend my career here."

"I think the community, the students, the parents and the staff have given me much more than I have given them, and I am really appreciative of being able to spend my career here."

"I think the community, the students, the parents and the staff have given me much more than I have given them, and I am really appreciative of being able to spend my career here."

"I think the community, the students, the parents and the staff have given me much more than I have given them, and I am really appreciative of being able to spend my career here."

"I think the community, the students, the parents and the staff have given me much more than I have given them, and I am really appreciative of being able to spend my career here."

"I think the community, the students, the parents and the staff have given me much more than I have given them, and I am really appreciative of being able to spend my career here."

"I think the community, the students, the parents and the staff have given me much more than I have given them, and I am really appreciative of being able to spend my career here."

"I think the community, the students, the parents and the staff have given me much more than I have given them, and I am really appreciative of being able to spend my career here."

"I think the community, the students, the parents and the staff have given me much more than I have given them, and I am really appreciative of being able to spend my career here."

"I think the community, the students, the parents and the staff have given me much more than I have given them, and I am really appreciative of being able to spend my career here."

"I think the community, the students, the parents and the staff have given me much more than I have given them, and I am really appreciative of being able to spend my career here."

Principal has seen changes

By Victoria Mitchell
RECORD STAFF WRITER

When Dennis Colligan began his Northville Public Schools career things were just a little different around Northville.

"He started in 1974 when we were a small-town school district," said Leonard Rezmierski, Northville Public Schools superintendent.

Colligan said the population changed quite a bit during the 1970s and 80s.

"We had a low of about 1,000 kids at the high school," Colligan said. "To a high now of 2,100, of course we're bigger than we've ever been this year."

Colligan said historically attendance went up to about 1,300-1,400 and leveled off at about 1,200 before it would grow again.

"I was able to see a lot of growth; a lot of change within the community and the school district; a lot of people coming and going; and the population has definitely changed," he said.

Biggest challenge

The biggest challenge Colligan said he faced as principal of Northville High School was trying to deliver a personal experience to a student body hovering at 2,100 young adults.

"One of our goals since I started with the administrative team was to make sure kids are involved with their high school and not just a 7:30-2:15 student," Colligan said. "To offer activities outside of the athletic world and band and music."

Initiatives like gaming club, SADD, Make a Difference club and Rotary Interact helped offer respite for everyone.

"The personality of the high school is largely dependent on what the kids do," Colligan said. "We work hard to try and get students involved."

"I think that is what high school is all about."

Another challenge Colligan said he faced while changing from a 1,000-student enrollment to 2,100 kids: knowing every student's name one day, then suddenly realizing it's no longer possible.

"I can remember when it was 1,000 kids or 1,200 kids and you knew every body, it was just one of those things you needed to do," he said. "You miss that, that personalization and you miss that as you grow."

Biggest success

Rezmierski said Colligan's career is about never losing focus.

"What he has taught us is phenomenal," Rezmierski said.

But Colligan won't acknowledge personal successes.

"When I look at success as a person, I have a hard time individualizing that it is all me," Colligan said. "It is just success that the team has had, success we've had as a school and as a unit."

"I try not to take credit as a person, it is a team approach."

Colligan lists success as watching students come in as nervous freshmen and leave as mature young adults, with so many wonderful opportunities.

Other success stories include seeing the smiles on students' faces as they are accepted to the college of their choice.

"Knowing they were able to pursue the further degrees because of training and some of the background they've had at Northville High School and certainly from their parents," he said.

A word of advice

Colligan has this advice for his successor: "continue the relationship with the people you work with, continue the open relationship and open-door policy with students, and be personable on the job."

"Lend that personal element that people are comfortable to come in and talk."

Colligan said he hopes people feel that way about him. He hopes that is his legacy.

"I think when you come in as the principal of such a large school, with 125 staff members plus and 2,100 kids, which means over 4,000 parents and central office folks ... I think you have to be approachable."

"And I think the biggest thing that a principal needs to have and one of the most important communication skills that a principal needs to have is to be an active listener."



The answer is ...

By Victoria Mitchell
RECORD STAFF WRITER

As principal of Northville High School, Dennis Colligan experienced years when one day never matched another.

It's been a profession where fielding responsibilities was like standing in front of school doors on the last day of the year.

So what was the biggest surprise of taking the leadership reins? "The one thing I didn't prepare for is ... I might have to answer 300 different questions everyday and that was really surprising to me," Colligan said.

Colligan said he knew he answered a lot of questions as an assistant principal, and watched his mentors answer query after query. But it wasn't until he assumed the high school's lead administrative role that it really hit him.

"A lot of them are minor decisions and just common sense things, but boy you get asked a lot and you really have to be on guard and ready to give a response," he said.

Colligan said questions came from students, faculty, parents, administrators and outsiders calling in.

"You just have to be prepared to answer a lot of concerns," he said.

Victoria Mitchell can be reached at (248) 349-1700, ext. 122 or vmitchell@gannett.com.

When Dennis Colligan joined Northville Public Schools in 1974...

- Faced with impeachment for his role in the Watergate affair, President Richard Nixon resigns
- Vice President Gerald Ford is sworn in as the 38th President of the United States
- President Gerald Ford pardons former President Richard Nixon
- OPEC ends oil embargo begun in 1973
- Patricia Hearst, daughter of multimillionaire publisher Randolph Hearst, is abducted
- Screaming - running naked in a public place - becomes a fad
- Golda Meir resigns as premier of Israel
- Henry "Hank" Aaron hits his 715th home run, breaking the record set by Babe Ruth
- Miami plays Minnesota in the Super Bowl
- The Oakland A's play LA Dodgers in the World Series

- Muhammed Ali knocks out George Forman and regains the heavyweight title.
- "People" magazine debuts with Mia Farrow on the cover
- "The Sting" wins an Academy Award for Best Picture
- "Killing Me Softly With His Song" by Roberta Flack wins Record of the Year at the Grammys
- People mourn the loss of Bud Abbott, Dizzy Dean, Duke Ellington, Charles Lindbergh and Ed Sullivan
- Movies released this year are: "Chinatown," "The Godfather Part II," "Day for Night," "Blazing Saddles," "The Towering Inferno" and "Alice Doesn't Live Here Anymore."
- Top TV shows are: "All in the Family," "Sanford and Son," "Chico and the Man," "The Jeffersons" and "M*A*S*H"

SOURCE: W. H. WALKER

POLICE BRIEFS

In the park

Police cited a 22-year-old Commerce man June 20 for allegedly urinating in public at Northville Recreation Park. The man told police he was aware of the public restroom nearby. He was given a July 9 court date at the 35th District Court in Plymouth.

Purse found

Police were dispatched to Babies R' Us on Haggerty Road after an unknown person turned in a black leather purse, containing more than \$1,275 in cash found in a shopping cart outside the store, according to the store manager. Police were unable to locate any identification from the purse. The case remains open.

Gas and go

Police were dispatched to the Mobil gas station on Six Mile and Haggerty roads after a 29-year-old Redford Township man, driving a 1993 GMC pickup truck, allegedly stole \$30 worth of gas. Police said a sales associate approached the suspect while he attempted to leave via Haggerty Road, but the suspect turned his vehicle around and fled through the north exit onto Six Mile Road.

Police contacted the suspect who said he would make full restitution to avoid prosecution. Police said if full payment was not received, a warrant for the suspect's arrest would be issued. The case is closed.

Family trouble

A 36-year-old Northville Township woman reported family trouble after her husband allegedly pushed and knocked her to the floor. According to reports, the couple is going through a divorce and the woman asked for her new credit card. The woman told police her husband knocked her to the floor and slammed the door, saying she had been evicted from the bedroom. The woman did not want police to contact her husband at this time. The case is closed.

Break-in

Police were dispatched to Northville High School after an 18-year-old female custodian

and her mother, working in the school cafeteria, witnessed two male suspects allegedly break into their car and steal a Louis Vuitton wallet containing \$30. Police were unable to locate the suspects. The case is closed.

Stolen on lunch

A Toll Brothers Construction manager called police after a condenser valued at \$1,400 was allegedly stolen while workers were at lunch. According to reports, the manager said he was working in the basement of a home on Pine Hurst when an unknown suspect cut the piping and electrical wiring from the machine and fled the scene. The case remains open.

Busted

A 22-year-old Detroit man was arrested from Meijer on Haggerty Road after he was caught allegedly stealing five bottles of Grey Goose vodka. According to reports, loss prevention officials observed the man place the bottles into a grocery bag inside a shopping cart and attempt to exit the store. Police arrested the man, who was given a court date for today at the 35th District Court in Plymouth.

Garage invasion

Police were dispatched to a home on Weatherfield after the homeowner observed an unknown male suspect inside her garage. According to reports, the man fled to an awaiting car once he noticed the homeowner. Police said nothing was stolen from the garage. The case is closed.

Identity theft

An 18-year-old Northville Township woman called police after being contacted by Community Financial Credit Union in reference to several suspicious transactions on her account. According to reports, three June 3 transactions were made from Montreal, Quebec in the amounts of \$83, \$86 and \$89. The woman said she didn't allow anyone to use her account information. The woman told police she had canceled and destroyed the credit card. The case is closed.

City nearing decision on police chief replacement

But state rep. candidate asks: do they need one?

By Maureen Johnston
RECORD STAFF WRITER

Northville police chief candidates had five minutes to prioritize an in-basket of problems Friday.

The time-management exercise, along with role-playing with irate citizens and an oral exam, were part of the regimen being used to select a new City of Northville police chief. A city consultant put the five finalists through their assessment paces in order to rank their capabilities for the city's top cop job.

Meanwhile, police Capt. Mike Carlson is filling in for recently retired chief James Petres.

City Manager Patrick Sullivan expects to have a replacement named by August. Until then, he said Carlson will continue wearing two hats.

"It's going great," Sullivan said. "He's doing two jobs."

Department leadership

But Carlson's double-duty is a stop-gap measure, Sullivan said, and he discounted a recent public claim that cities the size of Northville and Plymouth do not need a police chief.

"That department needs a department head," Sullivan said. "The kinds of questions that a police chief gets called for in the middle of the night you don't want me answering. 'Do we need to get a search warrant?' 'The suspect's in the building,

■ Chief Vacancy
Candidates: 80 applicants narrowed to 5
Hire date: Expected August
Salary range: \$76,000-85,000
Staff size: 15 full-time sworn officers

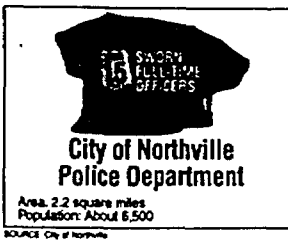

do we kick the door down?' 'You want someone with a law enforcement background that can answer those questions.'"

As part of his bid for the 20th District state representative seat, Plymouth resident Jason Vorva suggested Northville police sergeants can adequately schedule and supervise police personnel, reporting directly to the city manager.

"In these economic times, I think it's a great opportunity for small municipalities to look at what they really need," Vorva said. "For cities this size, you don't really need any officer higher than a sergeant."

"They don't need another level of administration," Sullivan said he does not know of any city that does not have a police chief. He said he has not scrutinized the department's structure during his two months in Northville, but the chief's position calls for after-



Photo by JOHN HEIDER/Northville Record

Acting City Northville police chief Mike Carlson reviews paperwork with newly-hired officer Claudia Finn.

hours judgment calls during special circumstances, as well as routine responsibilities.

"It's not just the things he does all day long when he's actually in the building," Sullivan said. "There are communities that have a public safety chief, but he has to have expertise in police and fire areas."

"Here, they are separate functions."

Adding staff

With the recent addition of Claudia Finn and the offer pending hire of another patrol officer, Northville Police Department will return to 15 full-time sworn officers. When the new chief joins the force, two sergeant vacancies will remain.

"There hasn't been any discussion of the framework of the organization," Sullivan said. "I want to continue it (as is) with the new chief."

Friday afternoon, Sullivan reviewed with the consultant results of the evaluations to determine which of the candidates, all men, to interview. After reviewing 80 resumes, the city manager narrowed to five the candidates for the consultant to scrutinize.

"It's a full day they put the candidates through," Sullivan said. "That gives us an objective, very credible assessment of their qualifications for this job."

"The next step is the actual interview."

Sullivan said candidates vying to replace Petres, who retired in April after 34 years on Northville's police force, are small-city chiefs or command officers in larger Michigan cities. Each candidate asked for confidentiality until making the final cut, he said.

The city council budgeted a \$76,000-\$85,000 annual salary range, plus health insurance and pension benefits.

OBITUARY POLICY

The first seven lines of an obituary are published free of charge. After that, there is a fee of \$3 a line. Pictures may be published for \$25.

*Deadline for obituaries is Tuesday at 10:00 a.m. for publication in Thursday's newspaper.

For more information, call 888-999-1288, or contact your funeral home.

*Holiday deadlines are subject to change.

ADELSON EYE & LASER CENTER

Dr. Howard B. Adelson
Eye Physician & Surgeon • Board Certified Ophthalmologist
Fellowship Trained LASIK and Cataract Surgeon

Comprehensive Medical & Surgical Eye Care

- Most Insurances Accepted
- Welcoming New Patients
- Flexible Scheduling
- General Eye Exams
- Advanced Cataract Surgery
- Eyelid Surgery
- Diabetic Eye Care
- Medicare Provider
- LASIK
- Conductive Keratoplasty (CK)



LASER VISION CORRECTION

248.449.9292 215 East Main, Suite 202 Northville, MI 48167

Summer Hours:
Sat. - Thurs. 11am - 10pm
Fri. & Sat. 11am - 10pm

Paradise Park

The Birthday Capital!

GO KARTS • MINIATURE GOLF • TRAMPOLINES
• SOCCER CAGES • CLIMBING WALL • ARCADE
• LASER TAG • BIRTHDAY PARTIES • GRADUATION PARTIES
• FIRST COMMUNIONS • CORPORATE EVENTS
• FAMILY PICNIC AREA • HOMEMADE PIZZA, SUBS & MORE

<p>MON. - THURS. ONLY</p> <p>1 FREE Miniature Golf 10 FREE Arcade Tokens with purchase of 1 Miniature Golf</p> <p><small>With this coupon. Exp. 7.31.06</small></p>	<p>FRI. - SUN. ONLY</p> <p>Buy One Get One FREE Miniature Golf</p> <p><small>With this coupon. Exp. 7.30.06</small></p>	<p>FREE</p> <p>Trampoline Center with the purchase of 3 Go Kart Tickets</p> <p><small>With this coupon. Exp. 7.31.06</small></p>
--	---	---

45799 Grand River, Novi • 248.735.1050 • www.paradiseparknovi.com

Northville Christian School

Preschool, Childcare and Kindergarten - Eighth

We Have been preparing children to excel in life for 25 years in academics and character.

- Culture of Integrity
- Effective literacy program
- Saxon math
- Resource room

- Hands on science
- Fine arts & computers
- Childcare
- Sports

Enrollment is now open. Call for a visit.

41355 Six Mile Road • Northville, MI 48167 • 248-348-9031

website: www.northvillechristian.org • email: school@northvillechristian.org

DRAW DATE
JUNE 30th - 8 PM
Must be present to win.

Hot DAYS Cool CARS

WIN 2 MUSTANG CONVERTIBLES PLUS \$2500^{Cdn} IN GAS MONEY!

June 1 - July 4

Print one ballot per day. Deposit them all at once or spread them out over either draw date: June 30 - 8 pm or July 4 - 4 pm. Ballots deposited in the drum on June 30 will be carried over for the July 4 draw.

For more information call 1-800-991-7777.

DOWNTOWN: officials gear up, gathering volunteers is next step

continued from 1A

phase is ready to be launched. I anticipate numerous volunteers will step forward — both from the city and the township.

"Downtown Northville is the community's downtown and there is a lot of enthusiasm and energy out there to help move projects on to further strengthen this core area of the community."

Time to sign up

At last week's Northville Downtown Development Authority meeting, board members agreed to restructure their body, incorporating volunteer assignments.

Development authority members — downtown property owners, merchants, residents and city officials — will chair subcommittees stacked with volunteers to target specific tasks.

"Volunteers will be able to focus on areas of special interest to them," Mittman said. "I believe they will be excited to help. And to see the results of their efforts come to fruition."

Greg Presley, authority board member and chair of the downtown steering committee that worked alongside Beckett and Raeder representatives, proposed dividing tasks into five categories: organization, business mix, marketing/promotion, design/aesthetics and parking/circulation.

"We're going to need more than just DDA members to get any work done," City Manger Patrick Sullivan said, adding some of the steering committee volunteers will remain involved.

"We're going to need more than just DDA members to get any work done,"

Patrick Sullivan
Manager, City of Northville

Time to make it happen

According to Presley's proposal, each subcommittee will be chaired by a development authority member, supported by volunteer voices. The downtown development group will serve an oversight role.

The business mix group will look at retention, recruitment and downtown businesses, and encouraging healthy practices, such as standardized hours of operation and open hours during special events.

The design/aesthetics subcommittee will help police design, ensure proper maintenance routines and help develop an effective sign program, Presley said.

Mittman said he would like to see the greenspace expanded. "The major studies are complete,"

What's next
What: Northville Downtown Development Authority meeting
When: 8 a.m. Tuesday, July 18
Where: City Hall council chambers
Who: Public invited
More info: (248) 349-1300

he said. "It is now time to make things happen."
"I look forward to the upcoming implementation phase."

Maureen Johnston can be reached at (248) 349-1700, ext. 103, or via e-mail at mjohnston@gannett.com.

Want To Volunteer?

To do: Downtown Makeover

To Volunteer
Call (248) 349-1300

My Interests:

Marketing Design

Business Mix Parking

NOTICE

is hereby given that on 7/20/06 at 4:30pm at STORAGE UNLIMITED 15176 BECK ROAD, PLYMOUTH, MI the undersigned, STORAGE UNLIMITED will sell at Public Sale by competitive bidding:

Michael Moran
Unit #C38
Household Furnishings, Misc. household goods, Misc. boxes/bags, Other Misc. Items

Dianne E. Downing
Unit #G25
Misc. household goods, Misc. boxes/bags, Recreation Equipment, Other Misc. Items

Make a Difference
RECYCLE

ON CAMPUS

Northwood University

Northville residents, Lauren Brackel, Jeffrey McCullough, Ian O'Gieblyn, Eric Pfefferle and Alena Vancleave, were named to the spring 2006 term dean's list at Northwood University.

Washtenaw Community College

Northville residents, Kim Aigner, Kara Beckerman, Hailey Buchinger, Karen Formella, Heather Gillespie, Deanne Hatton, Christopher Haywood, Mai Ishihashi, Tammy Impullitti, Kirsten Migoski, Jason Moore, Lindsay Pearce, Daneil Pitts, Jordana Ringo, Laura Roberts, Troy Ross, Elizabeth Senak and Melissa Zilch were named as honor students at Washtenaw Community College in May 2006.

Indiana University-Purdue University, Fort Wayne

Northville resident, Michelle Manno, was recently honored at the 2006 North Central Sociological Association June meeting. She won second place in the undergraduate student paper competition.

Wal-Mart Scholarship Recipients

Northville High School student, Ashley Flohr, has been awarded a Sam Walton Community Scholarship for 2006-07.

Grand Valley State University

Northville residents, Katherine Bradley, Jeffrey Breault, Joshua Cassidy, Emily Cummins, Charles DeCoster, Lauren Denomme, Lauren Duggan, Maureen Emaus, Anna Griebel, Kristin Kirk, Svaja Mikulionis, Drew Montgomery, Karen Paterson, Andrew Paterson, Brooke Richard, Courtney Siracusa, Victor Sultana, Patrice Wade and Adam Zobl, were named to the winter 2006 dean's list at Grand Valley State University.

Steer clear from harm, install smoke alarms!

PREVENT FIRE. SAVE LIVES.
<http://www.usfa.fema.gov>

United States Fire Administration
Federal Emergency Management Agency



HOME EQUITY LINE OF CREDIT

Low introductory rate **4.99%** APR* | Regular variable rate as low as **7.25%** APR*
Home Equity Line of Credit | after October 31, 2006

Apply for a new Home Equity Line of Credit or switch your account to LaSalle Bank by July 15 and take advantage of our low intro rate. You can borrow up to 100% of your home's equity. Plus, pay no closing costs, application fees, or appraisal fees.* Just call (866) 904-8462, stop by any LaSalle branch, or visit lasallebank.com. More flexibility. More value. More access to life's good stuff.

Making more possible **LaSalle Bank**
ABN AMRO

lasallebank.com

*The introductory rate of 4.99% APR ends on the last date of the billing cycle applicable to October 31, 2006. The last date of the billing cycle is November 5, 2006. To qualify for the introductory rate, the account application must be submitted no later than July 15, 2006, and the proceeds of the new Home Equity Line of Credit may not be used to pay off an existing LaSalle Bank Home Equity Line of Credit or Fixed Rate Home Equity Loan. After the introductory period, the Annual Percentage Rates (APRs) on LaSalle Bank's Home Equity Lines of Credit are based on Prime plus or minus a margin. Prime is the highest Prime Rate as published in the "Money Rates" section of The Wall Street Journal on the last publishing day of the calendar month immediately preceding the billing cycle. The margin tied to Prime varies and depends on the approved credit line amount and combined loan-to-value. As of May 31, 2006, Prime was 8.00% and the regular rate on LaSalle Bank's Home Equity Line of Credit products varied between 7.25% and 11.00% APR. Prime is a variable rate; as it changes, the APR on your account will change. The maximum APR is 21%. A balloon payment will result at the end of the ten-year draw period. Home Equity Lines of Credit advertised are limited to owner-occupied, 1-4 family principal residences, do not include bridge lines of credit, and are subject to no less than a second lien position on your property. You must carry insurance on the property that secures this loan. Flood insurance required if necessary. There is a \$50 annual fee after the first year. Annual fee may be waived for customers participating in certain LaSalle Bank checking account programs. There is a \$395 early termination fee if you close your account within 36 months after account opening (except MA and NJ). All third party closing costs are paid by LaSalle Bank in states with no state or local mortgage, intangible, or stamp taxes. Consult your tax advisor concerning the deductibility of interest. The APRs are subject to change without notice. This offer may not be combined with any other home equity offer. LaSalle Bank N.A., LaSalle Bank Midwest N.A., Members FDIC ©2006 LaSalle Bank Corporation

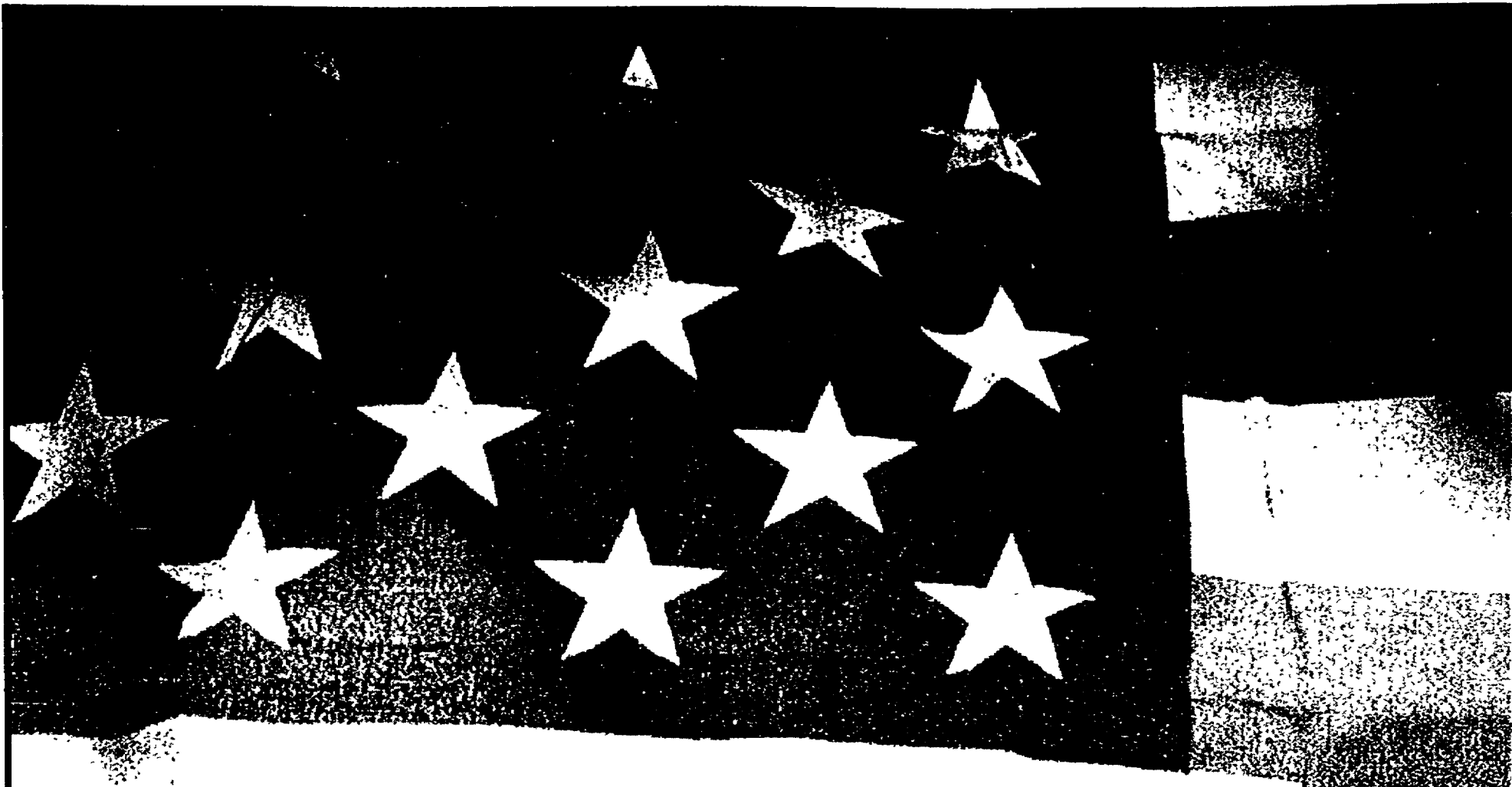

1st Presbyterian Northville Presents
Patriotic
Worship Service

Sunday, July 2nd
One service only at 10:30am

***Come worship and sing your
favorite Patriotic Songs***



**First Presbyterian
Church
of Northville**
**200 E. Main
Downtown Northville**
248-349-0911

Welcome, district guests

High school serves as site for national learning conference

By Victoria Mitchell
RECORD STAFF WRITER

Katie Doerr Parker might just take a breather today. She's been working hard all week making sure educators are learning how to build better schools.

Parker, Northville Public Schools Director of Instructional Projects, was in charge of overseeing a national learning conference hosted at Northville High School.

The three-day "Professional Learning Communities at Work Institute" conference was expected to wrap-up today, bringing nearly 1,000 educators from across the country to the high school.

"It has really been an honor, but a lot of hard work and a lot of thanks needs to go to many, many people in the district for working very hard," Parker said. "The event is the first of this kind for the district."

School officials said there is no financial benefit for the district, but the community exposure is welcomed.

Parker said the Northville Chamber of Commerce placed brochures in registrants' packets, highlighting places to dine.

"Unfortunately ... they are going to miss the Thursday evenings where the stores are open, but we are just hoping they will have a chance to get into town and see the community," Parker said.

School officials said the district was one location contacted last summer to host the event.

Northville Public Schools Assistant Superintendent for Instructional Services Casey Reason said the district was ultimately selected because of its investment in the community, new facilities and long-time involvement with the Galileo Leadership Consortium.

The consortium is a nationally recognized leadership develop-

"The event is the first of this kind for the district."

Katie Doerr Parker
Director of Instructional Projects,
Northville Public Schools

ment program for educators comprised of nine school districts, three community colleges and two regional educational service agencies in southeastern Michigan.

Reason said Northville Public Schools began exploring Professional Learning Concepts more than five years ago.

"A number of our staff and administrators have been trained and we now see evidence of Professional Learning Community strategies in nearly all our school improvement initiatives," he said.

At Moraine Elementary School the staff created a formal learning community complete with ongoing book talks to support shared learning, and a very structured shared governance process allowing for staff input at all levels.

"We've been doing this for quite awhile," Parker said. "Different buildings are more involved than others, but every building is certainly aware of it and practices some of the concepts."

Keynote speakers at the conference this week included Solution Tree experts Dr. Richard DuFour, Rebecca DuFour and Robert Eaker, Ed.D.

Conference attendees learned how to:

- Align school practices to promote higher levels of learning for all students;

- develop strategies to provide additional time and support for students who experience initial difficulty in learning; and

Professional Learning Communities

The Professional Learning Communities at Work Institute is designed to help educators implement strategies for improving their schools.

"It is finding a way to work together for a common goal for the benefit of the students and also for the benefit of those who teach," said Katie Doerr Parker, Northville Public Schools Director of Instructional Projects. "So it becomes transforming."

"It turns both students and teachers and administrators into life-long learners."

Parker said Professional Learning Communities is headed by Dr. Richard DuFour.

She said DuFour is a former high school principal known for developing a way of making a very large high school seem smaller and more responsive to students by getting teachers involved in empowerment and decision making.

• create a new sense of what their school might become by investing the practices of some of North America's most successful schools.

"It can change your culture completely," Parker said.

More than 50 Northville educators including teachers, principals and administrators, attended the conference at a discounted rate.

Victoria Mitchell can be reached at (248) 349-1700, ext. 122 or vmitchell@gannett.com.

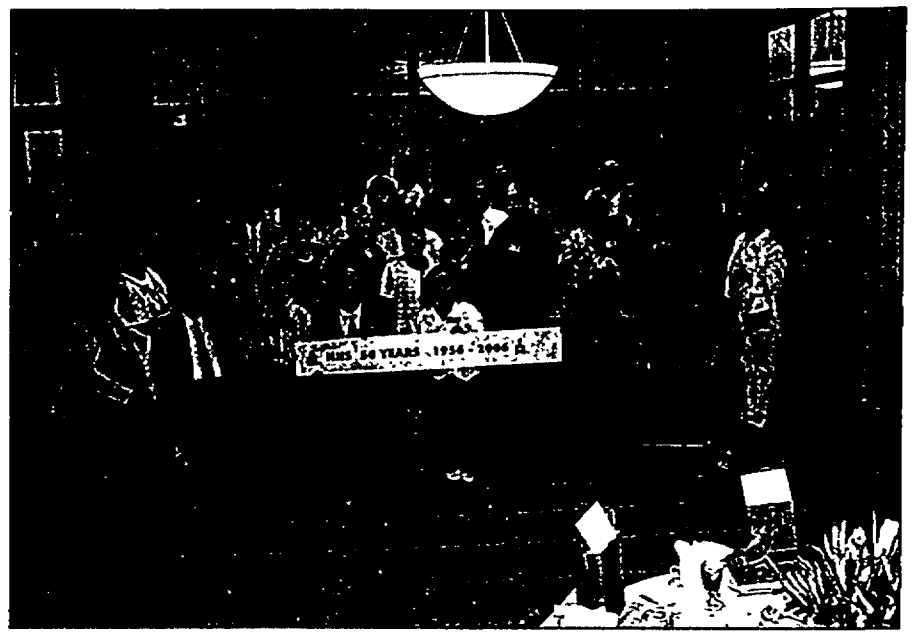

Class of 1956 returns!

Maintaining a tradition they pledged at the time of their graduation, members of the Northville High School Class of 1956 have been meeting every five years for a reunion. On June 17, they marked 50 years. Of the class of 94 students, 49 classmates plus 29 guests and spouses attended the Novi Sheraton Hotel event after traveling from throughout Michigan, Indiana, Virginia, Wisconsin, Florida, Iowa, Kentucky, California, and Colorado. Donald Van Ingen, a former teacher and coach, was a special guest at the reunion planned by Conrad Doan, Suzanne (Mairs) Lily, Sue (Cantrell) Dahlager, Norman Somers, Delores (Burrell) Barber, Gerald Davis, Darwin Teshka and Joan (Perry) Iversen. The morning before, many classmates toured the Main Street school administration building, their former high school, and Amerman elementary school.

Library Board filing deadline approaches

The filing deadline for candidates interested in serving on the Board of Trustees of the Northville District Library is July 20.

The seven-trustee board, responsible for overseeing the operation, policy-making and resource allocation of the Northville District Library, is expected to have four available trustee positions at the end of the year. The library district includes the City of Northville and Northville Township.

City and township residents are

eligible.

Trustees elected this year will serve four-year terms, beginning in January 2007. Meetings of the Board of Trustees are held on the fourth Thursday of each month. Trustees also serve on several standing committees, for which meetings are also scheduled.

Petitions are available at the library, and potential candidates must collect a minimum of 40 valid signatures. The deadline for filing the petitions at the Wayne County Clerk's office in the Coleman Young Municipal

Building is July 20.

Candidates may pay a \$100 filing fee in lieu of the nominating petitions. The Nov. 7 election is a non-partisan ballot.

For more information, contact Library Director Julie Herin at (248) 349-3020

Got Helmet?



Never Clean Your Gutters Again!

Protecting Homes Since 1981

GutterHelmet
GUTTER PROTECTION SYSTEM

800 979-4844

www.AtlasGutterHelmet.com

2 Weeks Only! FREE GUTTERS! Call for Details...

INSTANT HEDGE



HUGE & FULL

Create an evergreen privacy hedge with

EMERALD GREEN ARBORVITAE

5' potted reg. \$59.99
now **\$49.99**

FOUNTAINS

Closed Tuesday, July 4

MANAGER SPECIAL
SELECT HANGING BASKETS Starting at **\$4.99**



33% OFF

PLYMOUTH NURSERY and GARDEN CENTER

734-453-5500

www.plymouthnursery.net

9900 Ann Arbor Rd./Plymouth Rd.
7 Miles West of I-275
1 1/2 Miles South of M-14
Corner of Gottliebson Rd

SUMMER HOURS: Mon-Sat 8:30-6
Fri 8:00-7 • Sun 10-5
Offers Expire 7/31/06

Gap Outlet is growing.

So are your choices.

Gap Outlet - Kids & Baby Now Open

Tanger Outlets - Kensington Valley



Gap Outlet - Kids & Baby

Tanger Outlets - Kensington Valley

1475 N. Burkhardt Rd., Howell, MI

I-96 at M59, Exit 133

www.tangeroutlet.com

Gap Outlet - Kids & Baby

Tanger Outlets - Kensington Valley

1475 N. Burkhardt Rd., Howell, MI

I-96 at M59, Exit 133

www.tangeroutlet.com

Budget: No new teachers

Board adopts \$63 million budget; new hires not included

Third installment in a series regarding the Northville Public Schools 2006-07 budget, including the impact on teachers, administration, infrastructure and children.

By Victoria Mitchell
RECORD STAFF WRITER

School officials delivered the good news-bad news edict Tuesday night while approving Northville Public Schools \$63 million budget.

The good news: no teacher layoffs. The bad news: no new teachers will be hired as originally anticipated.

The news comes to the chagrin of Amber Slusser and other Thornton Creek Elementary School parents.

Slusser is concerned static teacher hiring will mean one less section of third grade classes at her son's elementary school.

She is also afraid class sizes will creep up.

"My son will be in a class 44 percent larger than last year ... and I think it will impact his education," Slusser said.

School officials said eliminating the need for a fourth third-

grade teacher at Thornton Creek means class sizes are expected to be 25-26 student per class.

"We're a district that is very committed to low class size," said board president Karen Paciorek.

Board members said maintaining low class size is still their main priority and studying enrollment for all district buildings will continue through the summer.

School officials said they originally hoped to hire nearly 10 K-12 teachers, including a new counselor at Northville High School.

The announcement that no new teachers will be hired came during a special-call meeting last week, when board members decided to cut by 66 students enrollment projections for the fall.

The enrollment adjustment eliminated about \$500,000 in expected state per-pupil revenue.

School officials said they decided to adjust student enrollment projections after input from building principals and an end-of-the-year count showed previous estimates were too high.

Northville Public Schools Assistant Superintendent for Administrative Services David Bolitho said this is the first slow down he's seen since 1991.

"Is this an event, or is this the beginning of a trend?" he said.

According to district documents, a \$100,000 contingency fund exists to hire up to two teachers, if needed.

"We're noting it so people don't think this is the absolute final word," said John Street, Northville Public Schools director of business and finance. "We're still looking at enrollment as they walk in the door."

Board treasurer Joan Wadsworth expects adjustments will be made.

She said the economy, contract negotiations and a pending state announcement regarding per-pupil funding could trigger changes.

Wadsworth said historically the district has refrained from making many mid-year budget changes, but does not anticipate that trend to continue in Northville Public School's new fiscal year, which begins July 1.

Victoria Mitchell can be reached at (248) 349-1700, ext. 122 or vmitchell@gannett.com.

SCHOOL BOARD MEETING NOTEBOOK

June 27 Meeting

Judith Wollack was absent
Next Meeting: July 11

NHS principal named

Board members offered a one-year probationary contract to Robert Watson to serve as the high school's new principal. Watson, a current Northville High School assistant principal, will become principal effective July 1.

Northville Public Schools Superintendent Leonard Rezmierksi said Watson is the man to take the high school well into the next decade, tackling issues including unprecedented growth and new graduation requirements. He complimented Watson as a man and an administrator.

"He is a visionary, yet practical," Rezmierksi said.

Go Mustangs

Northville Public Schools Board of Education members and administrators congratulated Northville High School athletes for a job well done this year. Congratulated at the meeting were: girls' varsity soccer team, 2006 state runner-up; 2006 boys' varsity baseball, 2006 district champions; and Jasen Turnbull and Michael Yassay members of the 2006 boys' track team named "All-State."

Teacher honored

Hillside Middle School social studies teacher Dee Krause was honored by members of the board for receiving the National Council for the Social Studies teacher of the year award. Hillside Middle School

Assistant Principal Heidi Capraro quipped, "Dee is so important now she requires an escort," while standing beside Krause as she was honored. Krause thanked the Hillside team for creating a scholarly school culture, paving the way for her national recognition.

Budget adoption

The decision was unanimous to adopt the Northville Public Schools \$63 million 2006-07 fiscal year budget. The document is pending the announcement of per-pupil funding by the state, and school officials said mid-year adjustments are expected.

Policy considerations

Two Northville Public Schools policies were unanimously approved for first reading by board members Tuesday night. Policy 5119 Students Leaving or Entering the School District and 5142 Wellness Policy will come before board members again for adoption. Board members said the Wellness Policy is a state mandate regulating students' health and fitness. Changes to Policy 5119 address students who complete their junior year and move, allowing them to return to the district to complete their senior year.

Cablecast

The Northville Public Schools June 27 regular board meeting was video taped by Dan Davis and will air to Comcast subscribers on Channel 18 at 9 p.m. Monday, July 3.

SIDING WORLD HOMEOWNERS WELCOME!

CertainTeed & Wolverine VINYL In Stock!

VINYL SIDING SALE \$46.95
Colors + \$3.00

ALUMINUM COIL STOCK \$59.95
24" x 36" White

VINYL SOFFIT \$48.50
FOR CEILING

CUSTOM TRIM \$49.50
Bring in your measurements and we will custom trim your trim.

SIDING WORLD'S WINDOW SHOWROOM
DISTRIBUTORS FOR:

SEAMLESS GUTTERS
6" GUTTER \$1.49 Per Foot
5" GUTTER 95¢ Per Foot

GUTTER LEAF GUARDS
MANY TYPES IN STOCK!!
COLORS AVAILABLE

LIVONIA
248-478-8884

MI. CLEVELAND	DETROIT	CLIO	MANSON HTS.	WYANDOTTE	IVANKSTER	YALLED LAKE	WATERFORD
588	313	810	248	784	784	248	248
698-7800	891-2902	687-4730	585-9050	284-7171	728-0400	824-8908	874-1300

Botsford Commons Senior Community

INDEPENDENT APARTMENTS • ASSISTED LIVING CENTER • SKILLED NURSING CENTER

The hub of the community offers residents a pool, exercise room, library, arts & crafts room, media room, general store and dining room

Independent Apartments

Are you searching for a new place to live without the responsibility of a large home? Botsford Commons offers one and two bedroom rental apartments which include: 24-hour security, emergency call services, priority access to health services, lawn and trash services, special outings and events.

For a tour and more information, call (248) 426-6903

Botsford Commons Senior Community is an affiliate of the Botsford Health Care Company
21450 Archwood Circle • Farmington Hills, MI 48336 • www.botsfordcommons.org

CITIZENS BANK

LOAN SPECIAL

RATES AS LOW AS

6.99%

 APR*

20-Year Term Home Equity Loan

Don't Wait to Take Advantage of These Great Rates!

Visit your local Citizens Bank office, log on at citizensonline.com, or call (800) 444-6989 to find out how you can take advantage of our low rates on home equity loans. Don't forget to ask about our great rates on boat and RV direct loans.

But hurry! This offer ends 7/1/06

CITIZENS BANK

*On a \$75,000 loan at 6.99% APR. Annual payment of \$4347. Advertised rate may be higher. Rate subject to change.

Northville Chamber of Commerce presents

northville GRUB CRAWL

Tuesday, July 25
6:00 to 10:00 p.m.

REV UP YOUR APPETITE

Make your way through twelve (12) restaurants, each offering free samples of appetizers and signature items along with cash bar specials.

Proudly sponsored by:
Ameriprise Financial- John Kish
Good Time Party Store & Custard Time
Remerica Hometown One- Patti Mullen
Gardenviews
Independence Village of Plymouth
Main Street Bank
Northville Record
Svoboda McDaniel Group
The Home Depot

PARTICIPATING RESTAURANTS

- Bahama Breeze
- Bonfire Bistro & Brewery
- Brann's Steakhouse & Grille
- Deadwood Bar and Grill
- Edward's Café & Caterers
- Sive Restaurant
- Genitti's Hole-in-the-Wall
- George's Senate Restaurant
- Little Italy Ristorante
- MacKinnon's Restaurant
- Poole's Tavern
- Uno Chicago Grill

HIGHLIGHTS

- Free shuttle service
Courtesy of Independence Village of Plymouth
- Free "Grub Crawl" T-shirt
- Grand Prize drawing for Outdoor Grill
Courtesy of The Home Depot

TICKET INFO

\$35.00 per person
(Must be 21 or over)

Tickets available at:
Northville Chamber of Commerce
Gardenviews
Good Time Party Store

For more information, call (248)349-7640.

COOKE: remodel would come at human cost

continued from 1B

Northville Public Schools, Cooke School has done for us in the past, the present and for Elizabeth's future."

Potentially telling Morrison the special education program will be removed from Cooke is one of many difficult decisions board members and district administrators face as they look for additional student space.

Seventh elementary

Deciding to remodel the 73,855-square-foot Cooke School building would mean moving the Wayne County Center program for physically, cognitively and dual-diagnosed impaired students.

Evicting 136 students from 14 Wayne County districts, including Northville, who are educated at the Taft and Eight Mile roads campus would be at the center of the plan.

School officials said if they terminated the district's agreement to house the program, the building would be remodeled at an undetermined cost and become Northville's seventh elementary school.

Northville Public Schools Superintendent Leonard Rezmierski said a one-year termination notice is required before relocating the locally based program.

Finding additional elementary school class space for the 2007-08 school year and beyond has become a top district priority since the failure of two February bond proposals totaling \$70.7 million.

The proposals included a \$25 million elementary school in the western portion of Northville Township, an area officials previously said was the fastest-growing part of the community.

Fall out

Rezmierski said reclaiming the Cooke building would not eliminate district management of the county center program, which includes Old Village School.

No changes would be made to Old Village School, and the district would continue managing its sister program now in the Cooke building.

But instead of running over to the Taft Road building for program needs, school administrators could

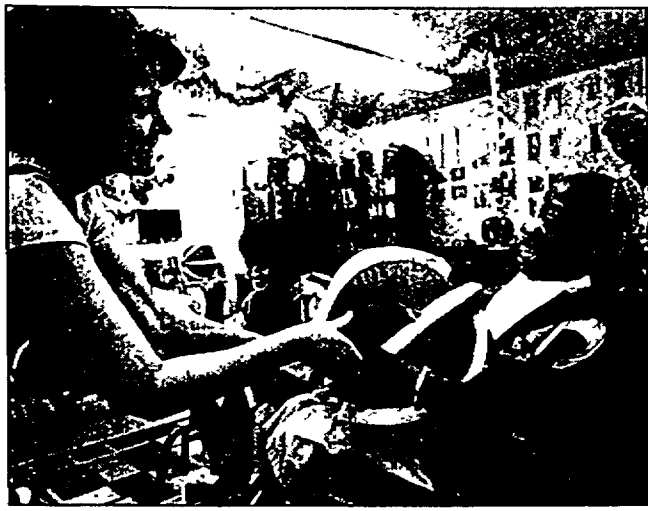

Photo by JOHN HEIDER/Northville Record

Cooke School teacher Martine Leech, left, helps student Brigitte Thomas.

"What is the implication of the extended program for Hillside and Northville High School?"

Karen Paciorek
President, Board of Education

be running to Wyandotte - another Wayne County community.

Northville would still oversee the program, Rezmierski said, but it's administrative responsibility would be located in another district.

Northville Public Schools Board of Education Treasurer Joan Wadsworth said part of the decision hinges on whether the district could find a reasonable location.

"We need to be doing this other piece (finding a new building) at the same time," she said.

Added value

Northville Public Schools Board of Education President Karen Paciorek said the loss to Northville K-12 students who've benefited from the interaction with Cooke School students would be significant.

"What is the implication of the extended program for Hillside and Northville High School?" she said. "Would we still maintain two classes at the high school?"

Currently, Cooke School satel-

lite classes are housed at Hillside Middle and Northville High schools, providing interaction between public and special education students.

Rezmierski questions the viability of satellite classes if they are housed in a far-off district.

School officials said center program students also participate in work programs with Northville businesses.

"We'd lose something that is valuable," Wadsworth said.

Who would attend?

But reclaiming Cooke would only be the first step toward solving Northville's growth concerns. Deciding which students would attend the renovated building would be the next challenge.

Cure-all

Though she's considering it, school board treasurer Joan Wadsworth is not sure if reclaiming Cooke School is the best long-term option. "Is this a cost effective solution for a period of time?" she wonders?

Officials said renovating Cooke School would not be a permanent fix for the district's impending growth. Officials said a maximum of 597 students could attend the school once it's been retro-fitted to suit elementary school children.

According to projection data, under some scenarios the district anticipates it would outgrow Cooke in six years. "It is not a solution forever," Wadsworth said. "Who knows what the future will hold."

School officials said renovating Cooke wouldn't take as much money as building a new school, but it would take more money than the district has. "So, one, we need to find out what the community thinks of these options and two: if we're going to have to ask for some kind of money, even if it is a relatively modest amount, we need to be about that relatively quickly," Wadsworth said.

Northville Public Schools Assistant Superintendent for Administrative Services David Bolitho said options include busing kids from subdivisions along Sheldon Road, which provide a direct and cost-effective route. Busing students to Cooke from the southwest portion of Northville Township may not be practical, he said.

School officials anticipate busing costs could be significant, though have yet to officially esti-

What would it take to remodel Cooke?

By Victoria Mitchell
RECORD STAFF WRITER

Northville Public Schools Assistant Superintendent for Administrative Services David Bolitho said reconfiguring Cooke School for a district elementary building would take some remodeling.

Bolitho said projects would include:

- Removing coat storage located in hallway lockers to meet the revised Life Safety Code;
- major remodeling for water supply and sanitary connections;
- construction of kindergarten and grades 1-5 playgrounds; and
- placing coat storage inside classrooms.

Bolitho said moving the coat storage to the classroom interiors would make the rooms smaller.

The district's minimum standard for first through fifth grade

classrooms is 700-square-feet, larger than several Cooke classrooms now.

School officials said on-site meetings with construction contractors are expected soon followed by remodel dollar amounts.

Bolitho said installing new lighting and removing adapted program equipment are also expected to make the list.

Northville Public Schools is exploring the option of using Cooke School as the district's seventh elementary school.

Currently the Eight Mile and Taft roads building houses a Wayne County Center program for emotionally, physically and cognitively impaired students.

Students from 14 Wayne County districts, including Northville, are educated at school.

Cooke School Fact & Comparison Sheet June 2006



Building	Square Footage	Lot Size	Capacity
Amerman	69,564	10.2	540
Moraine	66,864	10.0	445
Ridge Wood	90,366	15.2	580
Silver Springs	66,575	10.1	465
Thornton Creek	70,000	18.8	540
Winchester	69,319	10.0	540
Cooke	73,855	10.0	*

*Between 529-597 depending on configuration

SOURCE: Northville Public Schools

Other options

mate how much.

Members of the board of education authorized \$45,000 in additional transportation costs for the Northville Public Schools kindergarten relocation plan. The plan sent Ridge Wood Elementary School students to buildings throughout the district.

Bolitho said about 100 kids were affected by that plan, noting "this would be four times the amount."

No decisions have been made.

Wadsworth said board members will spend the summer discussing details of all possible solutions.

"We're hoping to have thoughtful analysis done by the end of the summer," she said.

Other options include adding portables, redistricting, new construction and using Early Education Childhood Center classrooms.

All study sessions are open to the public.

Free Report Reveals The Hidden Truth Of Headache Relief

Headache Victims Shocked and Amazed!
Livonia, MI - A newly released free report reveals what leading medical researchers have proven to be the cause of most headaches. To discover the truth about what your own doctor may NOT know about your headaches, call the toll-free 24-hour recorded message at 1-888-521-8128.

Take to the road with BIGGER, BETTER COVERAGE.

Receive discounts for multiple policies and coverage for all types of riders and motorcycles at Nationwide.



For special rates on Motorcycle Insurance, call a local Nationwide Agent today

Check the Yellow Pages or log on to www.nationwide.com

Nationwide
On Your Side
Auto Home Life Business

Nationwide Mutual Insurance Company and Affiliated Companies. Life insurance issued by Nationwide Life Insurance Company. Home Office: Columbus, Ohio 43215-3226. Nationwide, the Nationwide Framework and On Your Side are federally-registered service marks of Nationwide Mutual Insurance Company.

Summer Sale • June 29-July 31st

Carpet
Large Inventory In Stock
for Immediate Installation!

- Wood
- Laminate
- Vinyl

Custom Drapery
Initial Design
Consultation is FREE!

Midwest Carpet Broker

33752 Five Mile • 2 Blocks W. of Farmington Road • 734-513-9167

JULY 4TH Tanger Outlets Sale

plus a sidewalk sale

buy direct from over 70 brand name outlets

25th ANNIVERSARY 1981-2006

ENGAGEMENTS



Kremer-Balint

Scott and Kitty Kremer of Northville announce the engagement of their daughter, Kristin Elizabeth Kremer to Kevin Anthony Balint, son of Steve and Libby Balint of Westland.

The bride-elect is a 2000 graduate of Mercy High School and a 2005 graduate of Eastern Michigan University. She is currently employed by Barnes and Noble and by Marshall Music and serves as assistant conductor of the Livonia Youth Philharmonic of Michigan.

The groom-elect is a 1998 graduate of Franklin High School and a 2005 graduate of Eastern Michigan University. He is currently employed as an administrative assistant by TRAM, and is bass player for the Macomb Symphony Orchestra and the Southern Great Lakes Symphony Orchestra.

An August 2006 wedding is planned.



Gorshak-Gasparick

John and Maureen Gorshak of Northville announce the engagement of their daughter, Rachel, to Joseph Gasparick II, son of Joseph and Ann Gasparick of Kingsford.

The bride-elect is a 1999 graduate of Northville High School and a 2003 graduate of Michigan State University. She is currently employed at Kohler Company as a buyer with the Corporate Purchasing Group.

The groom-elect is a 1999 graduate of Kingsford High School and a 2003 graduate of Michigan State University. He is currently employed at Kohler Company as a buyer with the Power Systems Group.

A summer 2006 wedding is planned.



Corless-Baetens

Mr. and Mrs. Rick Corless of Acworth, Ga., formerly of Novi, announce the engagement of their daughter, Jennifer Lynne Corless to Kirk Bradley Baetens, son of Mr. and Mrs. Mike Baetens of Fla., formerly of Novi.

The bride-elect is a 1999 graduate of Novi High School and a graduate of Michigan State University receiving a bachelor's degree in Marketing. She is employed by Coca-Cola Enterprises.

The groom-elect is a 1994 graduate of Novi High School. He received an undergraduate degree from Arizona State University and a Master in Business Administration from Michigan State University. He is employed by Marketing Strategies Inc.

An October 2006 wedding is planned.

THINKING ABOUT...
CENTRAL AIR CONDITIONING
LENNOX
Innovation never left so good™
10 S.E.E.R.
In Stock
(734) 525-1930

- Free Estimates
- 0% Financing Available
- 5 Years Parts & Labor Warranty

Our 32nd Year!
UNITED TEMPERATURE
8919 MIDDLEBELT • LIVONIA
CE06421127

Community Bible Study
Wednesdays
7:00pm-8:00pm
at
21944 Rosedale Ct.
Northville

This is a Bible study for the whole community. No prior study of the Bible is needed and it does not matter what religious or spiritual background a person has. This will be a Bible Study that will have the Holy Spirit as its guide.

If another day of the week is better for you than Wednesday, give me call and let me know.

Some of the topics that will be discussed: How a person can be thoroughly furnished unto all good works. The two different kinds of understanding that the Bible tells us about, milk and meat. How to identify those that the Lord has sent to deliver his Word, and those who have not been called. Study about Jehovah's two sides. Also, what the Word of God says about government.

Call Jeremy Lane at
248-348-2452 for more info.

Herniated Disc Technology Discovered by NASA Scientists

Ann Arbor - A new free report has recently been released that reveals how breakthrough medical technology is offering new hope for sciatica sufferers. Discover how research has proven non-surgical decompression 86% successful in treating debilitating back pain. Find out how NASA's accidental discovery led to the most promising treatment today. For your free report entitled, "How Space Age Technology Is Solving Back Pain Without Drugs Or Surgery!" Call 1-800-469-3618 for the toll-free recorded message. Supplies are limited - call now. If phone lines are busy, visit: www.midsciherniation.com

CE06434552

Good Neighbor. GREAT RATES.

Looking for great rates and a secure place to grow your money? Call your local State Farm agent today for more information about a CD from State Farm Bank™.

CERTIFICATES OF DEPOSIT

90 days	4.60%APY*
180 days	4.70%APY*
1 year	4.75%APY*
2 years	5.50%APY*
3 years	5.50%APY*
4 years	5.00%APY*
5 years	5.10%APY*

State Farm Bank

LIKE A GOOD NEIGHBOR, STATE FARM IS THERE.™

FDIC

*Annual Percentage Yields as of 06/21/06. Rates subject to change without notice. Minimum balance to open an account and obtain the stated APY is \$500. Rates apply to deposits less than \$100,000. A penalty may be imposed for a withdrawal prior to maturity. Certificates automatically renew at maturity at the then-current rate for the same term.

STATE FARM BANK • HOME OFFICE: BLOOMINGTON, ILLINOIS • statefarm.com 06/05

verizon wireless

INTRODUCING THE MOST POWERFUL RAZR YET

THE ONLY RAZR TO COMBINE

NAVIGATION
VZ Navigator™ - Voice guided/visual interactive directions to any address in the U.S.

MUSIC
V CAST MUSIC - Take your music collection everywhere you take your phone

& THE NETWORK
The nation's most reliable wireless network

EXCLUSIVELY FROM VERIZON WIRELESS
The All New Multimedia RAZR V3m
\$69.99

After Mail-In Rebate: \$119.99 2 year price - \$50.00 Mail-In Rebate
With new 2 year activation.

EXPERIENCE VZ Navigator & V CAST Music

FREE FOR 30 DAYS (Airtime applies.)

FREE FOR ONE MONTH with a V CAST VPak (\$15 Monthly Access added to your Calling Plan thereafter.)

IT'S THE NETWORK™

CALL FOR FREE OVERNIGHT SHIPPING

CALL 1.877.2BUY.VZW **PARA ESPAÑOL** **CLICK verizonwireless.com**

VERIZON WIRELESS COMMUNICATIONS STORES

ANN ARBOR 2570 Jackson Ave. (next to Blockbuster) 734-769-1722 Branwood Mall (in Sears Wing, near Center Ct.) AUBURN HILLS Great Lakes Crossing Mall 248-253-1799 Courtland Center Mall (near JC Penney) BRIGHTON 8159 Chalfis, Suite C (off Grand River, in front of Target) 810-225-4789 BURTON 1295 S. Center Rd. (at corner of Lapeer Rd.) 810-743-4846 Courtland Center Mall CANTON 42447 Ford Rd. (corner of Ford & Lilley Rds., Canton Corners) 734-844-0481	DEARBORN 24417 Ford Rd. (just West of Telegraph) 313-278-4491 Fairlane Mall (3rd floor next to Sears) 313-441-0168 DETROIT 14126 Woodward (Model T Plaza) 313-869-7392 FARMINGTON HILLS 31011 Orchard Lake Rd. (Oron Mall 2 miles N. of the Palace) 248-538-9900 FENTON 17245 Silver Pkwy (in the Sears Plaza) 810-629-2733 FT. GRATIOT 4129 24th Ave. 810-385-1231 LAKE ORION 2531 S. Lapeer Rd. (Oron Mall 2 miles N. of the Palace) 248-393-6800 NORTHVILLE Three Generations Plaza 20580 Haggerty Rd. 734-779-0148 HOW 43025 12 Mile Rd. (Twelve Oaks Service Dr., North of Sears) 248-305-6600 Twelve Oaks Mall (lower level play area)	PONTIAC/WATERFORD 454 Telegraph Rd. (across from Summit Place Mall) 248-335-9900 ROCHESTER HILLS 3035 S. Rochester Rd. (at Auburn Rd.) 248-853-0550 ROYAL OAK 31921 Woodward Ave. (at Normandy) 248-549-4177 ST. CLAIR SHORES 26401 Harper Ave. (at 10 1/2 Mile) 586-777-4010 SOUTHFIELD 28117 Telegraph Rd. (South of 12 Mile Rd.) 248-358-3700 STERLING HEIGHTS 45111 Park Ave. (M-59 & M-53, Ucca Park Plaza) 586-997-6500 Lakeside Mall (Lower Ct. play area) TAYLOR 23495 Eureka Rd. (across from Southland Mall) 734-287-1770 Southland Mall 23000 Eureka Rd. (in the JC Penney wing)	TROY 1913 E. Big Beaver Rd. (Troy Sports Center) 248-526-0040 Oakland Mall (inside Main Entrance, next to Food Court) WESTLAND 35105 Warren Rd. (S.W. Corner of Warren & Wayne Rds.) 734-722-7330	OR VISIT THE VERIZON WIRELESS STORE AT CIRCUIT CITY ANN ARBOR AUBURN HILLS BRIGHTON BEARDEEN HARPER WOODS LAKESIDE HOW ROSELVILLE TAYLOR TROY WESTLAND	AUTHORIZED RETAILERS Equipment prices & return policy vary by location. Authorized Retailers may impose additional equipment related charges, including cancellation fees. BLOOMFIELD HILLS Global Wireless 1-888-607-1800 BRIGHTON Auto One Brighton 810-227-2808 Cellular and More 810-227-7440 CANTON Cellular and More 734-981-7440 CLARKSTON Cellular Technologies 248-625-1201 CLAYTON Communications USA 248-280-6390 CONCORD Cellular Source 248-360-9400 Wireless Tomorrow 248-669-1200 DEARBORN Kally Cellular 313-582-1130 FARMINGTON HILLS Cellular City 248-848-8800 FENTON Cellular and More 810-629-7440 FERRISDALE Communications USA 248-542-5200 FT. GRATIOT Wireless Solutions 810-385-3400 GRAND BLAINE Authorized Cellular 313-417-1000 HOW Cellnetics 517-548-7705 MACOMB Authorized Cellular 586-566-8555 MORRIS Herzinger Radio 734-242-0806 Herzinger Ton 734-384-7001 MT. CLEMENS Authorized Cellular 586-468-7300 NEW HAVEN Fusion Communications 248-437-5353 HOW MultiMedia 248-476-0077 OXFORD USA Wireless 248-236-9888 PLYMOUTH Ann Arbor Wireless 248-456-3200 ROCHESTER Wireless Xpert 248-650-5151 ROSELVILLE Authorized Cellular 586-293-6664 ROYAL OAK Fusion Communications 248-549-7700 SOUTHFIELD Wireless USA 248-395-2222 STERLING HEIGHTS Authorized Cellular 586-795-8610 SYLVAIA LAKE Wireless Link 248-681-1700 TAYLOR Cell Phone Warehouse 734-374-4472 TROY The Wireless Shop 248-458-1111 ITICA Mobile2Mobile Wireless 586-739-9977 WARREN Wireless Network 586-573-7599 WEST BLOOMFIELD Global Wireless 248-681-7200 WOOD Auto One 248-960-0500
--	---	---	---	---	--

Teamed with **Lucant Technologies**

See store for Return/Exchange Policy.

Proud sponsor of the Detroit Tigers

Activation fee/line: \$35

IMPORTANT CONSUMER INFORMATION: Subject to Customer Agreement, select Calling Plans, Rebate Form, V CAST brochure & credit approval. \$175 early termination fee & other charges. Rebate takes 8-10 weeks. While supplies last. Limited time offer. Network details & coverage maps at verizonwireless.com. V CAST Music: charges & conditions may apply. Offers, coverage & service not available everywhere. V CAST VPak Free Offer: Cancel by calling 1.800.2.JOIN within 1st month to avoid \$15 monthly fee; credit may not be on 1st bill, you can cancel anytime. VZ Navigator: Requires capable handset, download of VZ Navigator "Free Trial" and airtime for use; not available in existing VZ Navigator subscribers, offer expires 9/19/06. VZ Navigator only available in the National Enhanced Services Coverage Area; accuracy and completeness of info is not guaranteed; info about location of device will be used to deliver service. ©2006 Verizon Wireless

Ford Field flicks 'Nanny McPhee' July 3

The Farmers Market is staying put ... for now. Steve Fecht, board chairman of the market host, Northville Chamber of Commerce, wanted to quell rumors of imminent departure, saying the Thursday market will stay at the corner of Seven Mile Road and Center Street for the foreseeable future. He said the chamber is grateful to site owner, Northville Downs, for use of the site. The chamber wants to be part of downtown strategic planning efforts considering relocating the market, Fecht said. However, "We're not just going to pick up and move on a fluke."

Thank you, Jack Demmer Automotive Group! Northville Community Foundation president Shari Peters said Maybury Farm's pleas for a truck were heard! Last week, Northville resident Bill Demmer donated a half-ton diesel Ford pick-up to the foundation for use at the farm.

Have you seen Northville on your screen as you've been cable surfing lately? Ten businesses, the Northville Downtown Development Authority and the Chamber of Commerce split the cost of a year-long advertising promotion of Northville as a shopping and dining destination. The 30-second spots, produced by Comcast, can be seen on Fox News, HGTV, TBS Superstation, the Food Network and TNT. Check it out!

It's great to be gifted, but gifted and talented is even better. And no one knows this better than Northville students Connie Fu, Jonathan Lee, Hetali Lodaya, Allen Yuan, Catherine Culkin, George Li, Zachary Fuller, Rebecca Malinas, Katherine May, Teja Ravipati, Andrew Tang and Zhounan Xie. They were all recognized by the Michigan State University Gifted and

Talented Program.

No Tunes on Tuesday next week ... it's the Fourth of July. The Northville Parks and Recreation Department and Downtown Development Authority will resume its 11 a.m. concert series July 11 with Guy Louis and the Chautauqua Express in Bandshell Park. Louis is known for exciting performances with active audience participation, expert musicianship and light-hearted humor.

It's been a big year for Northville Public Schools Board of Education President Dr. Karen Paciorek. Not only was she recognized with one of the highest honors bestowed by Eastern Michigan University for her work as an early education professor, she also received the President's Award earlier this month. Presented to Paciorek at the board of education regular meeting, Paciorek was thanked for serving as board president for the 2005-06 school year.

The Independence Day parade keeps growing ... starting at 10 a.m. Tuesday, Main Street spectators will see music, floats, marching bands, clowns, children's characters, vintage and classic cars, a bike parade, a pet parade and Mrs. Michigan. Host for the eighth year, the Northville Community Foundation invited Lisa Barry and Tom Mackinnon to emcee the event.

No, it's not the Olympics, but three Northville young women went for the gold and scored. Katherine Ehlert, Emily Smith and Morgan Daul earned their Gold Awards, the highest honor presented by the Girl Scouts. Great job!!

In his weekly newsletter, Park Avenue financial plan-

ner Nicholas Hopwood acquaints his clients with a Reuter's report that says U.S. chief executive officers on average earn more in one workday than an average worker earns in 52 weeks. In fact, during 2005, American CEOs earned 262 times an average worker's pay, up from 1965 when CEOs at major companies earned just 24 times a worker's pay.

Time to showcase some homegrown talent at the Sherrus Gallery of Fine Art at 109 N. Center St., starting with a wine and cheese reception from 6-9 p.m. Friday, July 7. "Awakening II," a group exhibit featuring works by Sherri Mewha gallery and art supply store, will feature works by adult and children aspiring artists using a variety of styles and media.

There are still a few tickets left for the second annual Grub Crawl, slated for 6-10 p.m. Tuesday, July 25. Twelve restaurants are offering free samples of appetizers and signature items along with cash bar specials for our Northville Chamber of Commerce "Crawlers." Tickets are \$35 per person, 21 and older, and can be purchased at Gardensviews, Good Time Party Store or the chamber office.

"The Family Stone" is tomorrow's Friday Flick at the Northville Senior Community Center. Cost: \$1. Show time: 1 p.m.

Speaking of flicks ... break out the bug spray and head to Ford Field Monday night. The Northville Parks and Recreation Department is hosting the family flick, PG-rated, "Nanny McPhee," at dusk or about 8:30 p.m. Pre-show activities for the kids begin at 7 p.m. Show organizers suggest bringing bug spray, a blanket or lawn chairs and snacks, but no alcohol. Hot dogs, chips, soda and popcorn will be available for sale. For info: (248) 349-0203. Sounds like fun!



SOUTH LYON THEATER
Newly Renovated Theater

I HELD OVER!

Cars

Rated G 120 Min
Friday June 30th - 7pm
Sat, Sun, Mon & Wed
1, 4 & 7pm
Tues & Thurs 7pm

7pm Shows \$4.00
Matinees \$3.00
Tuesdays \$3.00

Wednesday
FREE sm. Popcorn
with paid admission

Thursday
FREE Ice Cream
with paid admission

Monday is
Senior Citizen Night
\$3 admission

126 E. Lake St.
437-4545

ANNIVERSARIES



Mr. and Mrs. Charles Ely, Jr.
Phyllis and Charles Ely, Jr. are celebrating their 50th wedding anniversary, June 30, with a small gathering of family and friends. They were married June 30, 1956. Charles is a lifelong resident of Northville and was a third generation businessman for 40 years in the city. He and his wife have been active members in the community for many years.

Mr. and Mrs. George Hall, Jr.
Mr. and Mrs. George Hall, Jr. of Northville, celebrated their 60th wedding anniversary, May 25, with a family dinner. They were married on May 25, 1946 in Vancouver B.C., Canada. They have lived in Detroit, Cleveland, Plymouth and been residents of Northville for 17 years. George was born in Detroit. He is active in the F.O.T. Club-Mill Race and is retired. Dale was born in Vancouver B.C., Canada. She is active in bridge clubs and is also retired. Both are St. Mary Hospital volunteers. They have four children, Linda Hall, Cheryl Cassidy, George A. Hall III and John R. Hall. Their daughter, Cheryl and her husband, Dennis celebrated their 35th wedding anniversary on May 28. They were married May 28, 1971 in Detroit. George and Dale have 10 grandchildren and seven great-grandchildren.

Being **NUMBER ONE** is nothing to celebrate.

This year, more than 163,000 people died from lung cancer - making it America's **NUMBER ONE** cancer killer.

But new treatments offer hope.

Join Lung Cancer Alliance in the fight against this disease.

lungcanceralliance.org

going on now
second take

extra 30% to 40% off

already-reduced spring and summer fashions and accessories

total savings 45% to 70%

storewide summer sale & clearance

an even greater selection, including new price breaks

Lord & Taylor

Northville Record

Rich Ramhoff
PRESIDENT & PUBLISHER
Grace Perez Perry
GENERAL MANAGER
David Aguilar
EDITOR
Richard Perlberg
EXECUTIVE EDITOR

Our fundamental purposes are to enhance the lives of our readers, nurture the home towns we serve and contribute to the business success of our customers.

Colligan: 32 years, and out

If he were a student, the fact that it took Dennis Colligan 32 years to get through Northville Public Schools would be a pretty good headline for us.

But since Colligan's tenure is measured in career years, his official departure tomorrow as Northville High School principal seems far less sexy, though no less noteworthy.

During the past five years, Colligan served as Northville High School principal. Prior to that, he served the district as a teacher, athletic director, coach and school administrator.

During that time, Colligan has been known as a good guy, affable and approachable. Quietly, though, he's also been tremendously effective, especially when it came to cultivating talent and encouraging teachers, administrators and students.

To his detriment, and to his lasting credit, Colligan was never a "me first" guy. Unlike those who often spend too much time furthering their own personal agendas, Colligan rarely got bogged down in petty politics and personal grudges.

He measured success by the success of those around him, not by his ability to manipulate bureaucracy or climb corporate ladders.

Ironically, Colligan's professional legacy should be shaped by the fact that Northville High School, where students have thrived during his five-year tenure as lead administrator, will open its doors and continue next year, unaffected by his absence.

The school will not suddenly fall apart. Students will not suddenly under-perform on MEAP tests. Teachers will not suddenly look for work elsewhere.

Colligan will leave. A new principal will replace him. And education will continue.

That's the way Colligan wanted it: no one is bigger than the team. His primary goal was never to serve as dictator, the world reliant on his every edict.

That says a lot. Colligan's departure is tough, not because of the shadows he cast. Rather, he will be missed most for his willingness to work amid the shadows of others, each day helping individuals be better than they ever dreamed.

Colligan taught us that caring, coupled with hard work, still counts for something in life, and that when used as fuel can make a difference. It's a redemptive lesson delivered on the verge of a teacher's final farewell.

Lesson learned, Dennis. Thank you ... for testing us.

City: Northville, pick a project

They came, we listened, you saw. The city's downtown strategic plan now is in the hands of the city council, complete with some great visual images of what is possible to revitalize the downtown. Images, as in, it will take putting pen to paper and words into action to make them reality. City leaders want to hear Northville's ideas for making those projects happen here. So, what's your passion? If it's expanding Bandshell Park, better connecting Ford Field, moving the Farmers Market or something else, pick a project, sign up. And let's get going.

Township: Clean up the clutter

Trustee Richard Henningsen believes outdoor sales are cluttering up the community, and he's vowed to continue asking for ordinance changes aimed at keep retail goods indoors. Township ordinance allows outdoor display, with a proper permit. Henningsen's concern: parking lots have become overrun with tents, instead of cars. We applaud Henningsen's watchdog approach, but caution good sense. Businesses complying with local ordinances have every right to exercise the limits of existing ordinances. Necessary change should come after careful planning department review and Board of Trustees consideration. No one likes clutter. But government acting on impulse is a mess no one needs to see.

Schools: Budget work in progress

More than any other year, the Northville Public Schools fiscal year budget is a work in progress. A \$63 million balanced budget was adopted Tuesday night with little or no "cushion." With teacher contract negotiations ongoing and only state preliminary funding numbers to work with, school officials will most likely be taking advantage of budget adjustments throughout the year. We applaud the board's dedication to working toward a feasible budget and encourage them to keep up the hard work at a time when tough decisions and solid leadership are needed most.



Thanks, Dennis!

Photo by JOHN HEIDER/
Northville Record

Northville High School principal Dennis Colligan chats with PTA members Chris Lysaght, left, and Vessa Afepopoulos at a ceremony to thank him for his years of service to the school. Colligan retires tomorrow.

LETTERS

T-h-a-n-k-s!

The Northville High School cheerleading teams would like to thank the community for their very generous support at our two car washes held on June 10 and June 17. We would also like to thank our generous hosts: Chip Snider, Northville Township Manager and his staff for the use of the old Northville Township Financial Building and The Good Time Party Store for the use of their facility and all the great beverages on such a hot day. Thank you to everyone.

Denise Bateson
NHS Cheer mom



The Northville High School cheerleading teams held two fund-raising car washes June 10 and June 17.

Labor pains

It was good to read about the Sept. 5 opening of schools in Northville. That was when schooling started when I was growing up in St. Louis, Missouri. It gives families a full summer to enjoy, right up to and including the Labor Day weekend. Some have said the bill was passed in Lansing because outdoor businesses and resorts needed the extra business. Maybe so, but the real beneficiaries are the students and parents. Everyone will learn to love the new, later start dates.

Bob Moreillon
Northville

NYA support

As an adult facilitator at Hillside Middle School's Challenge Day on April 26, I must commend Northville Youth Assistance and the Hillside PTSA for their vision in bringing this powerful program to our community.

The program is a testament to the commitment of school staff, parents and community volunteers in making Northville's youth feel valued, respected and appreciated. As a parent of a high school student and middle school student, I was impressed with the honesty and compassion of the Hillside seventh graders participating in the program. The dedication of so many staff, parents and community volunteers in helping facilitate two daylong programs was extraordinary.

If we truly value youth in our community, we need to help them respect, accept and tolerate their differences. Challenge Day did just that. Again, kudos to Northville Youth Assistance and Hillside PTSA for bringing this exceptional program to our community.

Steve Fecht
Chairman, Board of Directors
Northville Community Chamber of Commerce

Notable teachers

My wife and I just had to write and tell you about three extraordinary teachers our daughter had at Meads Mill Junior High this school year. Our daughter, Tawney Sayre, had a tough adjustment going into sixth grade this past school year. She was an excellent student all throughout elementary school. Her first junior

high report card came home filled with Ds. As her parents, you could just imagine her dismay.

We immediately contacted her primary teachers, Amy Balog, Wendy Martin and Kristi Maurer. They were more than eager to meet with us, and did. Our first meeting was just one of many throughout this past school year. These teachers were more than willing, at any time, to sit down with my wife and I. We also have to mention the numerous hours, many times after school hours, always keeping us up to date with missing assignments, test scores, etc. More importantly, the extra time they would spend with our daughter including their lunch times.

These three teachers went so far beyond what any parent would ever expect. They truly cared about helping our daughter's transition to junior high and succeed.

Our hats are off to you and the quality of teachers Northville Public Schools employ. You should be proud and honored to have Amy Balog, Wendy Martin and Kristi Maurer working in your school system.

Michael and Rita Sayre
Northville

District faces tough choices

In a Special Report published in 2004 by the Michigan Land Use Institute entitled "Hard Lessons," regarding Michigan's school construction boom, Northville's assistant superintendent David Bolitho stated, "We know our enrollment will stabilize and decline in the next 5 to 10 years. The community is getting built out and not many new families with children are moving in. But our elementary schools are already at capacity. Do we build another school now, knowing that one will have to close in a few years?"

That is a very timely question, since the recent Epic-MRA Northville Public Schools survey results show that respondents were almost evenly split as to whether there is currently enough space or if more space is needed, and as to whether they would be willing to send their children to a Livonia school leased by Northville Schools, when including undecided responses.

Another important consideration is the impact that the restructuring of the automotive and airline industries is having on the district, and enrollment in the district. In the next school year, the

district now expects 129 less students than originally projected, and 189 less students than projected in the Short Term Options Committee Report from January, 2005.

A less costly alternative to building new may be to renovate an existing Northville school. The "Hard Lessons" report highlighted that an independent feasibility study in the Jackson School District concluded that renovation was between 20 and 50 percent less expensive than building new, and in every case studied, building a new school cost more than renovating an older one. Cooke School is about 4.46 miles from Ridge Wood Elementary. It appears that this option should require less of a bond/tax increase.

It was recently reported that the Plymouth-Canton Schools are going to be leasing Washington Elementary from Livonia Public Schools for \$24,000 per month or \$288,000 for one year. Over a 10-year period that would amount to \$2.8 million dollars, a fraction of the \$25.24 million dollars recently proposed to build a seventh Northville elementary school. Furthermore, this option would not require any bond/tax increase.

Among the Livonia Elementary Schools reported to close this year: Taylor Elementary (located at 36611 Curtis Road, between Six and Seven Mile roads, east of Newburgh Road.) This school is about 7.28 miles from Ridge Wood Elementary, and less than three additional miles, compared to Cooke School.

Washington Elementary (located at 9449 Hix Road, Ann Arbor Road, west of Newburgh Road.) This school is about 9.21 miles from Ridge Wood Elementary, and less than five additional miles, compared to Cooke School.

Whether building new, renovating or leasing, the operating costs will have to come from the general fund, and according to John Street, operating a new school would cost \$600,000-\$700,000 per year. The less money spent on operating costs, the more money potentially available to maintain/improve education programs, and after all, it is the excellence in education that attracts residents to the district.

Ed Sarpoulos, vice president of Epic-MRA, recently stated that "People invest in millages and bonds because they believe there is a need." At this point, aside from redistricting, it appears that leasing elementary school space from Livonia Schools may very well be the most cost-effective, flexible and cautious solution, instead of building new or renovating.

Amid a statewide economic crisis, and a drastic decrease in stu-

dent enrollment, how could the district justify asking for a tax increase?

I hope that this leasing alternative "Board Study Session" agenda for equal consideration and presentation to the residents/taxpayers.

Laura J. Lorenzoni
Novi

Record 'Miss'-ed the point

I am the Executive Director of the Michigan High School Soccer Coaches Association. In a June 22 article ("All State Process Needs to be Tweaked") he took our association to task in regard to our All-State selection process and our Miss Soccer selection process.

As the Executive Director and a high school coach, I couldn't disagree more firmly. Not only did the article leave out important facts while attempting to slay us in the public eye, it made statements that are simply not true. Although there are many examples to select from, in my response I will consider only two.

The first has to do with criticism of our selection for Miss Soccer. The article openly states the writer has never seen our selection play, but criticizes that the player from a school in your readership should have been selected over the selection our committee made. I find it hard to take him seriously. With this statement alone, the column should have made it no further than the copy room floor. How can a sports writer be taken seriously when he makes the statement, "I have never seen her play but know she is not as good as ...?"

The second example is an inflammatory statement that our process is made up of coaches who favor small, west-side schools and that is why we made the decision we made about Miss Soccer. Again, he shows no journalistic integrity. Of the 13 coaches on the selection committee, eight of them would be considered from a large school and from the east side. In the past 10 years, our process has been the same. During that time frame, eight of the 10 Miss Soccer awards went to large, east-side schools. One of the two who were not east-side went to Lindsey Tarpley from a large school, Tarpley Central. Tarpley plays on the U.S. National team.

I believe the writer not only set out to hurt the credibility of our coaches, but took an unjustified shot at quality high school athletes to feed his own prejudice. He showed a lack of credibility and a complete lack of journalistic integrity.

I have prepared a point-by-point response. I believe he owes our association a public apology. Not because we disagree with his assumptions and conclusions, but because he obviously took little time to get the facts right. He used a paper that buys their ink by the barrel to make statements that are incorrect, based upon false assumptions and lack any work ethic in research.

David Hulings
Executive Director, MHSSCA

COMMENTARY

David Aguilar, editor (248) 349-1700, ext. 102 daguilar@gannett.com

Legislature status should match results: part-time

The most enduring memory I have from the Detroit Chamber of Commerce's policy conference on Michigan last month was the widespread scorn for the Michigan Legislature. The kindest thing I heard was "uninformed and inexperienced." Other, more candid comments ranged from those not suitable for a family newspaper to "unbelievably incompetent."



Phil Power

Granted, politicians have never been popular... but this is a level of contempt unknown two decades ago. Why?

Much of it has to do with the sad fact that legislators in Michigan are term-limited. State house members can stay six years, maximum; state senators, eight. And then they are out of those offices — for life.

The voters adopted term limits in 1992. The theory was that they would break the arbitrary power of long-time incumbents and encourage "citizen legislators" over professional politicians and special interests.

I supported term limits back then. Boy, was I ever wrong! I cannot for the life of me figure out why I should have reasoned that holding public office is a job where experience is a bad thing.

Today, most Michigan lawmakers have little idea of what they're doing or how to go about it. Ambitious legislators no sooner get elected to office when they start floundering to run for the next one, hitting up the lobbyists with their hands out to raise money for the next campaign.

Either that, or they start angling for some high-paying private sector job, with all the potential conflict of interest that implies.

Yet though term limits clearly don't mean good government — the only problem is that voters seem to still like the concept. Polls repeatedly show

overwhelming resistance to lengthening term limits, let alone doing away with them altogether.

So earlier this month I was delighted to read a column on the subject by Nolan Finley, editorial page editor of the Detroit News. Finley argued that lengthening the terms is merely fooling around the edge of the problem.

And he pointed out that you have to offer the voters something important if you're going to abandon term limits. His solution: Put on the 2008 ballot a proposal to eliminate term limits — in return for creating a part-time legislature. That makes a lot of sense.

A part-time legislature — which is what Michigan used to have, decades ago — would achieve the original goal of "citizen legislators." It should cost a lot less than our full-time body. And it would provide those elected with time to gain experience in their job, while at the same time leaving the voters the ability to throw the bums out if they screw up. (We have always had the best form of term limits: they are called elections.)

According to the National Conference of State Legislatures, it turns out only four states — California, New York, Pennsylvania and Michigan — have truly professional, full-time legislatures.

Of our neighboring states, Ohio, Illinois and Wisconsin have "full-time lite" lawmakers. Iowa, Minnesota and Indiana have legislators who spend around half-time in session.

Excited by the prospect, I called some of my smartest and most experienced friends to get what I figured would be support for the idea. To my surprise, several came down hard against it.

Craig Ruff, a self-described "child of the executive branch" who served in the Milliken Administration,

told me trading a part-time legislature for removing term limits would be "poison."

Politics and policy are tough enough, Ruff says, and expecting people with very limited investment in their job to do it well is silly. Worse, a part-time legislature would unduly increase the already strong power of the executive branch.

Probably the best political image strategist I know is Rick Cole, who served in the Blanchard Administration and who spent years trying to do away with term limits. To my amazement, Cole is dead set against a part-time legislature. "It's an invitation to wholesale conflict of interest. Take a guy who works for the railroad in his regular job. Is he really going to be independent of the railroad interests when he's in the capital?"

Paul Hillemonds, who served as Speaker of the House in 1995-96, knows the legislative process about as well as anybody. He does find the idea of trading a part-time legislature for an end to term limits attractive.

"It's worthwhile thinking hard about," he told me. "The present legislature lacks experience, basic legislative craftsmanship and the independence to take unpopular stands. And if you didn't place any limits on committee hearings, which is where the bulk of legislative work is really done, you wouldn't cease unlimited power to the executive."

My own view? I still think our term-limited Legislature is an albatross around the neck of good policy and good politics. But I fear that public attitudes are likely to favor term limits until a big-time scandal can be traced directly to the practice. At the end of the day, I still think the idea of a part-time legislature is a good one and worth serious debate.

For one thing is clear: We need to do better than we are doing now.

Phil Power is a longtime observer of politics, economics and education issues in Michigan. He would be pleased to hear from readers at ppower@hcnnet.com

NORTHVILLE RECORD STAFF



Grace Perry - General Manager
gperry@gannett.com
(248) 349-1700, ext. 120



David Aguilar - Editor
daguilar@gannett.com
(248) 349-1700, ext. 102



Ed Fleming - Acct. Exec.
efleming@gannett.com
(248) 349-1700, ext. 118



Maureen Johnston - Staff Writer
mjohnston@gannett.com
(248) 349-1700, ext. 103



Victoria Mitchell - Staff Writer
vmitchell@gannett.com
(248) 349-1700, ext. 122



Tracy Mishler - Staff Writer
tmishler@gannett.com
(248) 349-1700, ext. 107



Sam Eggleston - Sports Writer
seggleston@gannett.com
(248) 349-1700, ext. 104



John Heider - Staff Photographer
jheider@gannett.com
(248) 349-1700, ext. 106



Marcia Cromas - Receptionist
mcromas@gannett.com
(248) 349-1700



Karen Whitehart - Receptionist
kwhitehart@gannett.com
(248) 349-1700

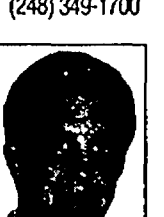

Billy Fraser - Graphic Designer
bfraser@gannett.com
(248) 349-1700, ext. 116

ORIN

JEWELERS

Summer Specials!

Summer Special Week 7!
4th of July Special!!!!
 Show your Patriotic colors!
 Bring in this coupon and receive 20% off any piece of Ruby or Sapphire Jewelry with Diamonds!
 Also get a free box of sparklers just for showing us this ad - no purchase necessary!!!!
 Coupon Valid June 29th thru July 1st

Don't forget to look at this exact spot next Thursday in the Northville Record for the next *Orin's Summer Special* of the week!

Puzzled ?

Wish somebody could help you put your car insurance puzzle together? As a local agency representing Auto-Owners Insurance Company, we're up to the challenge. For peace-of-mind protection and all your insurance needs, contact us today!

Auto-Owners Insurance
Life Home Car Business
 The "A" Rating Agency

C. HAROLD BLOOM INSURANCE
 108 W. Main, Northville
 349-1252

Too much STUFF?
 Garage Too Full?

We Can Help!

\$20 off per month
 any size storage unit for 1 year

Country Storage L.L.C.

Indoor/Outdoor Storage Facility
 Easily Accessible Location • 24 Hour access
 Computerized Gate with Code Access System
 Month-to-Month Leases
 Boxes, Locks and Packing Supplies

58000 W. 8 Mile Rd.
Phone 248-437-3333
 Office Hours: Mon-Thurs 10-6pm, Fri & Sat 10-5pm

SPOTLIGHT ON:
ALLERGY & ASTHMA

Presented by
Michael S. Rowe, M.D., F.A.C.E., C.C.R.I.

TRYING NEW THINGS

Asthma and allergies do not have to slow you down or prevent you from enjoying new experiences, but it's wise to talk with your allergist before trying a new activity or traveling to a new place. For example, camping is wonderful, but the potential for pollen exposure and insect stings is higher. Proper precautions include carrying injectable epinephrine. Trying a more strenuous sport like mountain climbing requires that you feel confident about your cardiovascular ability and that you monitor your breathing throughout the activity. High-elevation activities can pose problems for asthmatics, as can cold-weather sports. Scuba diving is not recommended for asthmatics, but snorkeling is a viable alternative. Swimming has proven to be a good activity for asthmatics.

At the ALLERGY AND ASTHMA CENTER OF MICHIGAN, we recognize that no two patients are alike, therefore, we are committed to working closely with each of our patients to develop a specialized treatment program for allergy relief and asthma management. To schedule an appointment, call (248) 473-6400. Our office is located at 24120 Meadowbrook Road, STE 201, Novi. New patients are welcome. "The Caring Allergist Who Gets Results."

PS: Before traveling, book a pre-trip physical with your allergist to discuss any precautions you may want to take.

www.allergyinfo.org

Historically speaking!

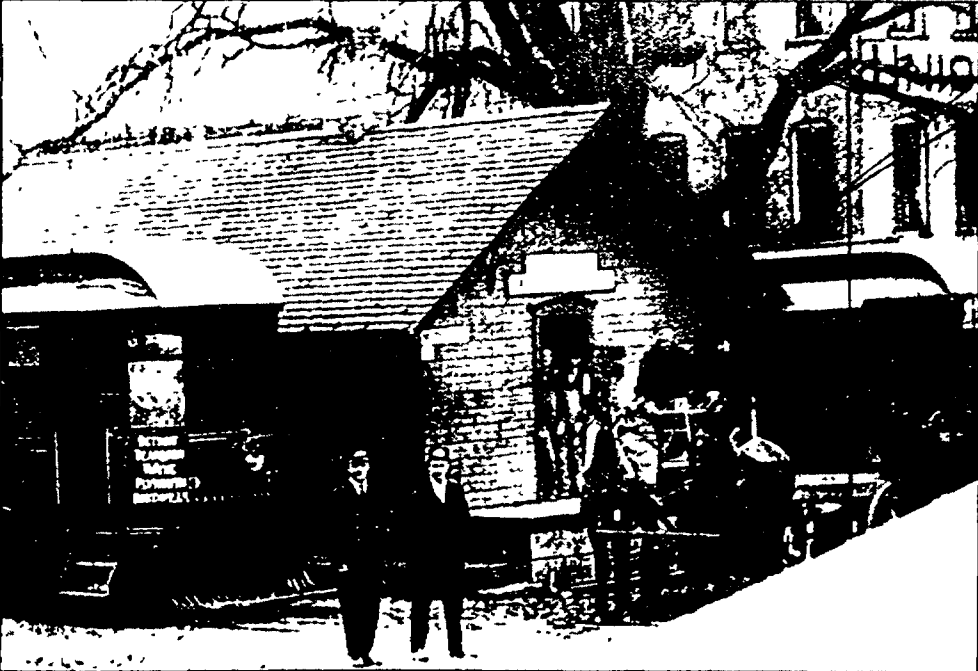

Photo courtesy of NORTHVILLE HISTORICAL SOCIETY

A Ford Motor Company post card, portraying the former Dubuar Manufacturing building purchased by Henry Ford in 1917. The building, located on Griswold and E. Main streets, operated for many years as the Northville Valve Plant.

Letters to the Editor

We welcome your comments on editorials, columns and other topics important to you in the Northville Record. Only submissions that include name, address and day and evening phone numbers, and that are verified by the Northville Record, can be considered for publication.

Letters to the editor of 400 or fewer words have the best chance of being published. All submissions may be edited for length, accuracy and clarity.

Letters to the editor, opinion and editorial columns, and articles submitted to the Northville Record may be published or distributed in print, electronic or other forms. Letters to the Editor, David Aguilar, Northville Record, 104 W. Main St., Northville, MI 48167. Fax: (248) 349-9832. E-mail: daguilar@gannett.com.

CITY OF NORTHVILLE CLOSE OF REGISTRATION AUGUST 8, 2006 ELECTION

To the Qualified Electors of the City of Northville, Wayne and Oakland counties, notice is hereby given that Monday, July 10, 2006 is the last day to register to vote or change your address for the primary election to be held on Tuesday, August 8, 2006.

The City Clerk's office is located in the City of Northville Municipal Building, 215 W. Main Street, Northville, Michigan, 48167, and is open Monday through Friday from 8:00 a.m. until 4:30 p.m. for the purpose of registering to vote. You may also register to vote at any Secretary of State branch office or County Clerk's office during their normal business hours.

Electors may also register to vote by mail by completing a Michigan Mail-In Voter Registration Application and forwarding the application to the City of Northville City Clerk at the above address by the close of registration deadline. Mail-in voter registration applications are available at the City Clerk's office, or by contacting the Elections Clerk at 248-349-1300 Ext. 1962, or on the City's website at www.ci.northville.mi.us. Please note that a person who registers to vote by mail is required to vote in person unless they have previously voted in person in the City of Northville, are at least 60 years of age, are overseas voters, or are handicapped.

(6-29-06 NR 293862) DIANE MASSA,
CITY CLERK

WHAT'S GOING ON?

Northville's Official Events Calendar • For a complete calendar, visit www.northvillerecord.com.

NORTHVILLE EVENTS

ECLIPSE BASEBALL CLUB
DATE: Home games are: July 4, 23, Aug. 26, Sept. 15-17

TIME: 1 p.m.
LOCATION: Ford Field, Mill Race Village
DETAILS: This is a group of Northville business men playing baseball, using rules from 1869.

ART EXHIBIT

LOCATION: Sherrus Gallery of Fine Art, 109 N. Center St.
CONTACT: (248) 380-0470
Tom Slack

DATE: Through Friday
DETAILS: This is an exhibit of impressionist art titled "Captured Light and Reflections," by artist Tom Slack.

Gallery Artists

DATE: July 7-21
DETAILS: This is a group exhibit of Sherrus Gallery artists titled "Awakenings II." An opening reception will be held 6-9 p.m. Friday, July 7.

Rock and Roll

DATE: Aug. 4-31
DETAILS: "It's Only Rock n' Roll—And We Love It" exhibit featuring rock and roll icons. An opening reception will be held 6-9 p.m. Friday, Aug. 4.

ART EXHIBIT

LOCATION: Swearingen Visions, 118 W. Main St.
CONTACT: (248) 347-1642
Prints

DATE: Through July 5
DETAILS: This is a collection of prints, created from the drawings and paintings of Nancy Swearingen.

FAMILY MOVIE

DATE: Monday, July 3
TIME: 7 p.m., children's activities; 8:30 p.m. movie
LOCATION: Ford Field, Downtown

DETAILS: The movie will be "Nanny McPhee." Participants are asked to bring chairs. Refreshments will be available. Children's activities will include crafts and balloon animals.
CONTACT: (248) 349-0203

FARM BREAKFAST

DATE: Tuesday, July 4
TIME: 7-10 a.m.
LOCATION: Northville Masonic Center, 106 E. Main St.

DETAILS: The cost is \$5 per adult and \$3 for children 12 and under.

INDEPENDENCE DAY PARADE

DATE: Tuesday, July 4
TIME: 10 a.m.
LOCATION: Downtown Northville
CONTACT: (248) 374-0200

ANNUAL GARDEN WALK

DATE: Wednesday, July 12
TIME: 10 a.m.-4 p.m.
DETAILS: This event is sponsored by Country Garden Club of Northville and includes five Northville gardens. Tickets are \$10. They are available at Gardenviews, 202 W. Main St.
CONTACT: (734) 591-0360

GARDENING ADVENTURE

DATE: Saturday, July 15
TIME: 10 a.m.-4 p.m.
DETAIL: This event is sponsored by the Gardeners of Northville and Novi Club. Tickets are \$10. They are available at Gardenviews, 202 W. Main St., WaterWheel Health Club, 235 E. Main St. and online at www.gardener-northville-novi.org. Registration is required.
CONTACT: (248) 348-1946

YOGA CLASS

DATE: Monday and Thursday through Aug. 3
TIME: Various
LOCATION: Tuesday, American Legion Hall, 100 Dunlap St.; Thursday, Northville Senior Center, 303 W. Main St.
DETAILS: The cost is \$87 per person. Registration is required.
CONTACT: Diane Siegel-DiVita, (248) 344-0926

CLOCK CONCERTS

DATE: Friday through August
TIME: 7:30-9 p.m.
LOCATION: Downtown bandshell

ART WALK

DATE: First Friday of every month
TIME: 5-9 p.m.
LOCATION: Downtown Northville
DETAILS: Art galleries, arts and crafts stores and restaurants will be open; art demonstrations and exhibits available in shops.

CONTACT: Tom James, Northville Camera and Digital Imaging, (248) 349-0105

FARMERS MARKET

DATE: Thursday through Oct. 26
TIME: 8 a.m.-3 p.m.
LOCATION: Northville Downs parking lot, corner of Seven Mile and Sheldon roads
DETAILS: More than 100 stalls include fresh produce, plants, flowers, baked goods, garden art, crafts and home accessories. This is sponsored by the Northville Chamber of Commerce and Prestwick Estates of Northville Hills Golf Club.
CONTACT: (248) 349-7640

MASTER GARDENER CLASSES

DETAILS: Wayne County classes will begin Aug. 15-Nov. 7
CONTACT: (313) 833-3412

MARQUIS THEATER

LOCATION: 135 E. Main St.
CONTACT: (248) 349-8110 or www.northvillamarquistheatre.com

GENITTI'S LITTLE THEATER

LOCATION: 108 E. Main St.
CONTACT: (248) 349-0522 or www.genittis.com
Dinner Theater "Mocha Madness"

DATE: Various days through August
TIME: 6:30 p.m.
DETAILS: Tickets are \$45 per person for dinner and show. Registration is required.

Concerts
DATE: July 15, "The Reflections"; Oct. 20, "The Frank Sinatra Tribute from Las Vegas"
TIME: 7 p.m.
DETAILS: Tickets are \$45 per person for dinner and show. Registration is required.

MAYBURY STATE PARK EVENTS

LOCATION: Eight Mile Road, between Beck and Napier roads
CONTACT: (248) 349-8390
Explorer Program

DATE: Today, "Oh Deer!"; Friday, "Habitat Hunt"; Saturday, "Michigan Mammals"; Tuesday, "Catch that Hummer"; Wednesday, "Nature Hike"

TIME: Varies
DETAILS: These one-hour programs, led by Explorer Guides, are for all ages. Registration is not required.

CONTACT: Karen, director of Explorer Program, (248) 349-3858 or visit www.friendsof-maybury.org

Maybury History Trail

DATE: Saturday, Sept. 30
DETAILS: This grand opening will include a ribbon-cutting ceremony and a virtual tour for those who cannot walk the length of the trail, family activities and the annual Northville Road Runner Classic (5K run, 5K walk and one-mile fun walk.) The trail is self-guided, commemorating the people who lived and worked at Maybury Sanatorium. Proceeds will benefit the American Lung Association of Michigan and Friends of Maybury State Park.
CONTACT: Jennifer McFall, (248) 374-9928 or Gary Hef, (248) 231-6114

MAYBURY FARM PROGRAMS

TIME/DATE: noon-5 p.m., Friday through Sunday
LOCATION: Eight Mile Road, west of Beck Road, look for the farm entrance sign
CONTACT: (248) 374-0200

LIBRARY LINES

LOCATION: 212 W. Cady St., near Northville City Hall; parking off Cady Street
TIME/DAY: 10 a.m.-9 p.m., Monday-Thursday; 10 a.m.-5 p.m., Friday-Saturday; and 1-5 p.m., Sunday
CONTACT: For information or to register for programs and request or renew library materials, (248) 349-3020

"FARM LADY" PROGRAM

DATE: Today
TIME: 11 a.m.
DETAILS: Margaret Schmidt will bring animals and present farm stories and activities. One hundred free tickets will be available at the information desk 10 minutes prior to the program. The library cannot accommodate day care, preschool or summer day camp groups.

ADULT BOOK CLUB

DATE: Monday, July 10
TIME: 7 p.m.
DETAILS: This is a discussion of the book, "Nickel and Dimed on (not) getting by in America" by Barbara Ehrenreich.

SUMMER READING PROGRAM

DATE: Through July 31
DETAILS: The theme is "Paws, Claws, Scales and Tales." This program is for ages 2-12 and will include storytime, special events, reading games and weekly prize drawings. Registration is required.

TEEN SUMMER READING PROGRAM

DATE: Through July 31
DETAILS: "Creature Feature" is the theme for this program. It is open to middle and high school students and will include prizes and activities.

FRIENDS STORE

DETAILS: The Friends Store, located inside the library, offers a variety of gifts for all ages. All proceeds benefit the library.

BOOK DONATIONS

DETAILS: Used books and materials are needed by the Friends of the Library. The library contributes to the collection and donates the rest to the Friends for sale, with proceeds benefiting the library. Donations are tax deductible. If you need assistance unloading books from your car, call (248) 349-3020 in advance to make arrangements.

LIBRARY BOARD OF TRUSTEE MEETINGS

DATE: Fourth Thursday of every month
TIME: 7:30 p.m.
DETAILS: Public is welcome.

Church Events

FIRST PRESBYTERIAN CHURCH OF NORTHVILLE

LOCATION: 200 E. Main St. (248) 349-0911
Portofino River Cruise

DATE: Saturday, July 15
TIME: 8-11 p.m.
DETAILS: This is a Hawaiian-themed cruise on the Detroit River. The cost is \$25 per person and includes door prizes, dancing and pizza. There is a cash bar.

Stratford Trip

DATE: August 18-19
DETAILS: The cost of this trip is \$350 per person and includes transportation, hotel and two musicals. Reservation deadline is July 5.

WARD EVANGELICAL PRESBYTERIAN CHURCH

LOCATION: 40000 Six Mile Road
CONTACT: (248) 374-5966
Single Adults

DATE: Sunday
TIME: 11:30 a.m.
CONTACT: (248) 374-5920
College Age

DATE: Sunday
TIME: 10:20 a.m.
CONTACT: Mark Tarpinian, (248) 347-3525



Feast your eyes on flowers!

The annual garden walk hosted by the Country Garden Club of Northville is right around the corner, from 10 a.m.-4 p.m., Wednesday, July 12. May Dubuc, left, walks in her 3/4-acre "sunken" garden with her cousin Lillian Roller and master gardener Sally Lemus, right, who helps Dubuc care for her Fox Hollow grounds. The tour will feature five gardens and a stop at Mill Race Historical Village's Cady Inn where sweets and lemonade will be served amidst a "Potting Shed" theme. The \$10 tickets are available at Gardenviews, 202 W. Main St.

FIRST UNITED METHODIST CHURCH

LOCATION: 777 W. Eight Mile Road
CONTACT: (248) 349-1144
Healing Service

DATE: First Monday of every month
TIME: 4 p.m.
Grief Support Group

DATE: Fourth Monday of every month
TIME: 7-8:30 p.m.

DETAILS: New Hope Center for Grief Support is offering this support group to those who have lost a loved one to suicide. Registration is not required.
CONTACT: New Hope Center for Grief Support, (248) 348-0115 or www.newhopecenter.net

Senior Events

Thursday, June 29
9 a.m.: Taking Off Pounds Sensibly
9:30 a.m.: Yoga
12:30 p.m.: Pinochle
1 p.m.: Tai Chi

By appointment: Massage Friday, June 30
10 a.m.: Strength Training
1 p.m.: Movie: The Family Stone

By appointment: Massage Monday, July 3
10 a.m.: Line Dance
10 a.m.: Oxycise I
11 a.m.: Oxycise II

12:30 p.m.: Pinochle/Euchre
Tuesday, July 4
Independence Day
Senior Center will be open 8 a.m.-2 p.m. for parade and picnic.

Wednesday, July 5
9 a.m.: Strength Training
10 a.m.: Oxycise Level I
11 a.m.: Oxycise Level II
noon: Bridge
By appointment: Foot Reflexology

BOARD GAMES

DATE: Tuesday, ongoing
TIME: 1 p.m.
LOCATION: Senior Community Center, 303 W. Main St.
CONTACT: (248) 349-4140

ONGOING CARD GAMES

Bridge
TIME/DAY: noon-3:30 p.m., Wednesday

Pinochle (double deck)
TIME/DAY: 12:30-4:30 p.m., Monday and Thursday

Pinochle (single deck)
TIME/DAY: 12:30-3:30 p.m., Friday

Euchre
TIME/DAY: 12:30 p.m., Monday
LOCATION: Senior Community Center, 303 W. Main St.

HEALTH WALKING

DATE: Monday-Friday
TIME: 8-10 a.m.
LOCATION: Senior Community Center gym, 303 W. Main St.

MILL RACE HISTORICAL VILLAGE

LOCATION: 215 Griswold Avenue, north of Main Street, near Ford Field
CONTACT: (248) 348-1845

continued on 17A

Picture Perfect Homes

A Truly "Homey" Home

You'll feel like you belong in this well-kept, charming colonial on over 1/2 acre in gracious Northville Estates. It is livable and lovable, quiet & comfortable ... and priced right at \$309,900.

Fabulous Location, Fabulous Home

Backing to Hines Park and deep in the sub, this quality custom luxury home has everything! Fantastic 1st flr Master, beautiful Kitchen, 4 BR, fab walkout LL w/bar & guest suite. \$899,900.

Great Condo With A Great View

Beautiful Cape Cod on the edge of a nature preserve, looking out to Northville Hills golf course. Outstanding floorplan. 1st floor Master Suite. Finished lower level. \$469,900.

Luxurious Ranch Condo

Open, bright and sunny, this hard-to-find 3BR, 3BA condo provides the ultimate in comfort for living and entertaining. Wonderful finished daylight basement w/bar. \$399,900



Phyllis Lemon

Professional One Real Estate
248-640-7952 or 248-567-3500

WHAT'S GOING ON? (CONT'D)

continued from 16A

Thursday, June 29: Archives open, 9 a.m.; Vacation Bible School, 9 a.m.; Rehearsal, 6 p.m.
 Friday, June 30: Archives open, 9 a.m.; Vacation Bible School, 9 a.m.; Wedding*, 4-7 p.m.; Rehearsals, 7 p.m. and 8 p.m.
 Saturday, July 1: Wedding*, 1-3 p.m.; Wedding*, 3:30-5:30 p.m.;
 Sunday, July 2: Mill Creek Church, 10 a.m.; Village open, 1-4 p.m.; Rehearsal, noon
 Monday, July 3: Wedding*, 11:30 a.m.-1:30 p.m.
 Tuesday, July 4: Office Closed, 9-1 p.m.; Village open, 10 a.m.; Eclipse Baseball, noon; Family Activities, 10 a.m.-4 p.m.
 Thursday, July 6: Archives open, 9 a.m.; MOMS Club, 10 a.m.; Rehearsal, 5 p.m.; Rehearsal Party, 5:45 p.m.; Rehearsal, 7 p.m.
 *Grounds closed to Public

Looking for You

BABY WALK VOLUNTEERS
 DETAILS: The non-profit statewide organization, "Tomorrow's Child, Michigan Sudden Infant Death Syndrome," needs volunteers to serve as team captains for the second annual Baby Walk. The walk will be Sept. 17 at Maybury State Park. Team captains will recruit friends and family to participate. Teams collect pledges for Sudden Infant Death Syndrome research.
 CONTACT: Carol, (248) 650-3729 or visit www.tomorrowschildmi.org

FOREIGN EXCHANGE STUDENTS
 DETAILS: Families are needed to host foreign exchange students for fall 2006. The commitment is to provide a room, caring home and meals.
 CONTACT: Judy Morante, (248) 380-7390

MEALS-ON-WHEELS
 DATE: Ongoing
 TIME: 11 a.m.-12:30 p.m.
 DETAILS: Permanent and substitute drivers are needed.
 CONTACT: Eileen at Allen Terrace, (248) 231-9950, 10 a.m.-1 p.m., Monday through Friday or Judy LaManna, (248) 348-1761

CAMERA CLUB
 DATE: Second Tuesday of every month
 CONTACT: Tom James of Northville Camera at northville-camera@sbcglobal.net, Ken Naigus at kdn@comcast.net or Northville Arts Commission, (248) 449-9950

ARTS COMMISSION
 DATE: Second Wednesday of every month
 TIME: 7:30 p.m.
 LOCATION: Art House, 215 W. Cady St.

BEAUTIFICATION COMMISSION
 DATE: Second Tuesday of every month
 TIME: 7 p.m.
 LOCATION: Northville City Hall, 215 W. Main St., Meeting Room B

HOUSING COMMISSION
 DATE: Second Wednesday of every month
 TIME: 3 p.m.
 LOCATION: Allen Terrace, 401 High St.

YOUTH ASSISTANCE
 DATE: Second Tuesday of every month
 TIME: 8 a.m.
 LOCATION: Youth Assistance office, 775 N. Center St.
 CONTACT: (248) 344-1618

PARKS AND RECREATION COMMISSION
 DATE: Second Wednesday of every month
 TIME: 7 p.m.
 LOCATION: Senior Community Center, 303 W. Main St.

PARKS AND RECREATION ACTIVITIES

LOCATION: 775 N. Center St., back entrance of Hillside Middle School
CONTACT: For registration and information on camps, classes and activities, (248) 349-0203 or visit www.northvilleparksandrec.org

TUNES ON TUESDAY
 DATE: Tuesday, ongoing
 LOCATION: Downtown band-shell
 TIME: 11 a.m.-noon
 DETAILS: These are free summer children's concerts sponsored by Northville Parks and Recreation and the Downtown Development Authority.

SUMMER DAY CAMPS
 DATE: Monday-Thursday through August
 TIME: 9:30 a.m.-4 p.m.
 LOCATION: Maybury State Park, Eight Mile Road, between Beck and Napier roads
 DETAILS: These camps are for ages 5-12. The resident fee is \$160 per week, \$245 per two-week registration and \$860 for eight weeks; non-resident fees apply. Campers will go on weekly field trips. Activities include games, sports, crafts, art and drama. Registration is required.

ART PROJECTS
 DATE: Tuesday through Aug. 8
 TIME: 5:30-6:15 p.m.
 LOCATION: Art House, 215 W. Cady St.
 DETAILS: Projects are based on letters of the alphabet each week. This class is for toddlers and their parents. The fee is \$82 per resident; non-resident fees apply. Registration is required.

ALL SPORTS CAMP
 DATE: Session I, July 10-14; Session II, Aug. 14-18
 TIME: 9:30 a.m.-3 p.m.
 LOCATION: Northville High School Plateau, located behind Amerman Elementary School, 847 N. Center St.
 DETAILS: This camp is for ages 6-12 and includes baseball, basketball, touch football, floor hockey, volleyball and whiffleball. The fee is \$150 per resident; non-resident fees apply. Registration is required.

BASKETBALL CAMP
 DATE: July 17-21
 TIME: 9:30 a.m.-3 p.m.
 LOCATION: Senior Community Center, 303 W. Main St.
 DETAILS: This camp is for ages 6-12 and includes includes lessons on dribbling, passing, teamwork, basic rules, a mini tournament and skill competitions. The fee is \$150 per resident; non-resident fees apply. Registration is required.

FOOTBALL CAMP
 DATE: Aug. 7-11
 TIME: 9:30 a.m.-3 p.m.
 LOCATION: Northville High School Plateau, located behind Amerman Elementary School, 847 N. Center St.
 DETAILS: This camp, for ages 6-12, will teach the basic fundamentals of the game of football, including daily scrimmages and contests. There will be no tackling or physical contact. The fee is \$150 per resident; non-resident fees apply. Registration is required.

BASKETBALL CAMP
 DATE: July 31-Aug. 4
 TIME: 9:30 a.m.-3 p.m.
 LOCATION: Senior Community Center, 303 W. Main St.
 DETAILS: This camp, for sixth-

eighth grade students, will teach the basics of basketball, game situations, floor awareness, rebound positioning and ball movement. It will also include individual dribbling, passing and shooting techniques as well as rebounding, blocking out and defensive awareness. The fee is \$150 per resident; non-resident fees apply. Registration is required.

T-BALL CAMP
 DATE: July 24-28
 TIME: 9:30-11:30 a.m.
 LOCATION: Senior Community Center, 303 W. Main St.
 DETAILS: This camp is for ages 5-6. Campers will learn the basics of throwing, catching, batting, running the bases, concentrating on where to throw the ball and when to run when a ball is hit. The fee is \$75 per resident; non-resident fees apply. Registration is required.

ALL SPORTS CAMP
 DATE: July 24-28
 TIME: 1-3 p.m.
 LOCATION: Senior Community Center, 303 W. Main St.
 DETAILS: This camp is for ages 5-6. Campers will receive group and individual instructions focusing on the basic fundamentals of floor hockey, basketball, soccer, touch football and kickball. The fee is \$75 per resident; non-resident fees apply. Registration is required.

WOMEN'S NETBALL
 DATE: Friday, ongoing
 TIME: 7-9 p.m.
 LOCATION: Senior Community Center, 303 W. Main St.
 DETAILS: Netball is a British

game, based loosely on basketball.
CONTACT: (248) 449-9947

PLAY AND MAKE MUSIC
 TIME/DATE: Various times; Tuesday-Friday, ongoing
 LOCATION: Soccer Zone, 41550 Grand River Ave, Novi
 DETAILS: This music and exercise class is for children under 4 and their caregivers. The class will include rhythm instruments, puppets, songs and creative movements. Registration is required.
CONTACT: (248) 349-0203

OPEN BASKETBALL
 DATE: Every Sunday
 TIME: 6-9 p.m.
 LOCATION: Senior Community Center, 303 W. Main St.
 DETAILS: The fee is \$3 per person.

TEEN BASKETBALL
 DATE: Every Thursday
 TIME: 3-5:30 p.m.
 LOCATION: Senior Community Center, 303 W. Main St.
 DETAILS: The fee is \$2 per person.

OPEN BADMINTON
 DATE: Every Tuesday and Friday
 TIME: 7-9:30 p.m.
 LOCATION: Hillside Recreation Center, 700 W. Baseline Road
 DETAILS: Competitive style badminton is available. All skill levels are welcome. The cost is \$7 per night.

TABLE TENNIS

continued on 16A

CHARTER TOWNSHIP OF NORTHVILLE NOTICE TO THE RESIDENTS

OFFICE CLOSING
 The Charter Township of Northville Administrative Offices will be closed on Monday, July 3 & Tuesday, July 4, 2006 in observance of Independence Day.
 The offices will reopen at 8:00 a.m. on Wednesday July 5, 2006. The Department of Public Safety (Police and Fire) will remain open.
 SUE A. HILLEBRAND, CLERK
 (6-29-06 NR 295109)

CHARTER TOWNSHIP OF NORTHVILLE PLANNING COMMISSION NOTICE OF REZONING

The Charter Township of Northville Planning Commission has scheduled a public hearing for Tuesday, July 25, 2006, at 7:30 P.M. at the Northville Township Municipal Office Building, located at 44405 Six Mile Road, Northville, Michigan. The Planning Commission will hear comments regarding rezoning the 15.48 acre township owned parcel located on the northeast corner of Sheldon and Five Mile Roads from R-3 (One-Family Residential) to B-3 (General Business). The property transfer will be subject to a development agreement.
 The public is invited to attend this public hearing and express their comments and ask questions. Written comments regarding the proposed rezoning will be received by the Northville Township Planning Commission at 44405 Six Mile Road, Northville, MI 48168.
 GEORGE MCCARTHY, CHAIR PLANNING COMMISSION
 (6-29 & 7-20-06 NR 295115)

CITY OF NORTHVILLE PUBLIC NOTICE NOTICE TO TAXPAYERS

2006 CITY OF NORTHVILLE REAL AND PERSONAL PROPERTY TAXES DUE JULY 1, 2006 WILL BE PAYABLE WITHOUT PENALTY AT THE CITY OF NORTHVILLE MUNICIPAL BUILDING, THE NORTHVILLE BRANCH OF COMERICA BANK, AND ALL BRANCHES OF COMMUNITY FEDERAL CREDIT UNION FROM JULY 1, 2006 THROUGH AUGUST 31, 2006.
 Taxes may be paid by mail, addressed to City of Northville, Attn: Tax Department, 215 West Main Street, Northville, Michigan, 48167, or in person at the City Clerk's Office Monday through Friday 8:00 A.M. to 4:30 P.M. The office will be closed Monday, July 4th, 2006.
 On September 1st, 2006 a two percent (2%) penalty will be added, plus an additional 1/2 of 1% interest per month beginning October 1st, 2006.
 JENNIFER L. SHEPARDSON DEPUTY TREASURER
 (6-29-06 NR 292679)

CITY OF NORTHVILLE HELMET BID

Sealed bids will be received by the City of Northville for the purchase of 30 Cairns Model 1010FD fire helmets, deluxe configuration, includes leather cushion liner, flannel crown pad, PBI/Kevlar earlap, carved brass eagle, 6" front holder and 4" PA tuftshield.
 Sealed bids must be submitted to the office of the City Clerk located in the City of Northville Municipal Building, 215 West Main Street, Northville, MI 48167 on or before Tuesday, July 11, 2006, 11:00 a.m. at which time the bids will be publicly opened and read aloud. Late bids will not be considered. Bids must be in a sealed envelope marked Helmet Purchase. For complete specifications, contact Chief Jim Allen at (248) 449-9920.
 The City of Northville reserves the right to reject any and/or all bids, in whole or in part, to waive any informality or irregularity in the bids, or to award any contract to other than the low bidder, should it be in the best interest of the City to do so.
 JAMES ALLEN, FIRE CHIEF
 DIANNE MASSA, CITY CLERK
 (6-29-06 NR 295117)

CITY OF NORTHVILLE TURN OUT GEAR BID

Sealed bids will be received by the City of Northville for 30 sets of Janesville Model #CMDM/PSUM-Isodri Command Fire Fighting Suits with 7.25 oz. PBI #CD Plus Matrix-Isodri. Specifications may be obtained at the office of the City Clerk. Questions relative to the bid and specifications should be directed to Chief Jim Allen at (248) 449-9920.
 Sealed bids must be submitted to the office of the City Clerk located in the City of Northville Municipal Building, 215 West Main Street, Northville, Michigan 48167 at or before 11:00 a.m. local prevailing time, on Tuesday, July 11, 2006 at which time they will be publicly opened and read aloud. Late bids will not be considered.
 The City of Northville reserves the right to reject any and/or all bids, in whole or in part, to waive any informality or irregularity in the bids, or to award any contract to other than the low bidder, should it be in the best interest of the City to do so.
 JAMES ALLEN, FIRE CHIEF
 DIANNE MASSA, CITY CLERK
 (6-29-06 NR 295119)

watch your Money Grow with us

4.75%^{APY} Money Market \$10,000+	5.15%^{APY} 6 Month Certificate of Deposit
5.25%^{APY} 12 Month Certificate of Deposit	IRAs \$250,000 ^{FDIC Insured}

Questions? Comments? Call us, and we'll respond personally within the same business day. That's our guarantee.

MICHIGAN HERITAGE Bank
www.miheritage.com

Farmington Hills 28300 Orchard Lake Rd.	Novi 21211 Haggerty Rd.
Troy 1917 E. Big Beaver	Wixom 28345 Beck Rd., Suite 102
Livonia 18770 Farmington Rd.	

Call us today at 1-800-914-3524

NOVI and WIXOM Drive thru's now open Saturdays 9 am - 1 pm

*APY Annual Percentage Yield. Must open a Classic Checking Account with a deposit of at least \$1,000 to receive advertised rates on the Certificates of Deposit or Money Market. Lower interest rates for balances less than \$10,000 in the money market. Rates subject to change. Rates effective as of June 25, 2006. Substantial penalty for early withdrawal on the Certificates of Deposit. \$150 service fee if the Money Market balance falls below \$2,500. **IRA is effective as of June 25, 2006. Any fees may lower the rate of return on the account. Certificates of Deposit require a minimum of \$500 to open. Member FDIC Equal Housing Lender

CHURCH DIRECTORY

For information regarding rates call The Northville Record or Novi News (248) 349-1700

ST. PAUL'S LUTHERAN MISSOURI SYNOD High & Elm Streets, Northville I. Luback, Pastor Church 349-3140 Sunday Worship 8:30 a.m. & 11:30 a.m. Contemporary Service at 11:00 a.m. Sunday School & Bible Classes 9:45 a.m.	FIRST PRESBYTERIAN CHURCH OF NORTHVILLE 200 E. Main St. at Huron - (248) 349-0911 Worship & Church School - 9:30 am & 11 am Children Available at All Services Youth Logos Prog.-Wed. 4:15 or 5:30 M/S/S/H Singles Place Ministry - Thurs 7:30pm Rev. W. Kent Cline, Senior Pastor Rev. James P. Russell, Associate Pastor
NORTHVILLE CHRISTIAN Experiencing Life Each Week Sunday Worship and Children's SuperChurch 10-15 AM For more information, contact us www.northvillechristian.org 41355 Six Mile Road - Northville 248-348-9030	OUR LADY OF VICTORY CATHOLIC CHURCH 770 Thayer, Northville WEEKEND LITURGIES: Saturday 5:00 p.m., Sunday 7:30, 9 AM, 11 AM, 12:30 PM Church 349-2621, School 349-3610 Religious Education 349-2559 Rev. Terrence Komec, Pastor
MEADOWBROOK CONGREGATIONAL CHURCH 21355 Meadowbrook Rd. in Novi at 8 1/2 Mile 248-348-7757 • MCC@congregationalbzbiz.com www.mbcoc.org • Sunday Worship 10 a.m. For further information, ask for Denise Part, Chairperson, the Board of Deacons Minister: Rev. Dr. E. Neil Hunt	GOOD SHEPHERD LUTHERAN CHURCH 9 Mile & Meadowbrook Worship: Ev. Lutheran Synod Sunday School and Adult Bible Class 8:45am Worship 10:00am Thomas E. Schroeder, Pastor - 349-0565
CHURCH OF THE HOLY CROSS EPISCOPAL (Anglican) 10 Mile between Meadowbrook & Haggerty Phone 248-427-1175 Sun. 7:45 & 10:00 am Holy Eucharist Sunday School & Nursery 10 am Rev. Karen Henry, Pastor www.churchoftheholycross.com	FIRST UNITED METHODIST CHURCH OF NORTHVILLE 349-1144* 8 Mile & I-96 Roads Worship Services 8am, 9:15am & 11am Rev. John Rice Rev. John Cook www.fumcnorthville.org
FAITH COMMUNITY PRESBYTERIAN CHURCH 44400 W 10 Mile, Novi, 248-349-2345 1/2 mile west of Novi Rd Sunday 9:00 a.m. & 10:30 a.m. Service Dr. Richard J. Henderson, Pastor	FIRST CHURCH OF THE NAZARENE on Haggerty Rd North of 8 Mile Rd Sunday School 9:30 a.m. Morning Celebration 10:50 a.m. (248) 348-7600 Dr. Ron Sake, Pastor
ST. JAMES ROMAN CATHOLIC CHURCH NOVI 46325 10 Mile Rd. Novi, MI 48374 Sunday 5:00 p.m. Sunday 8:30 & 11:30 a.m. Reverend George Chamley, Pastor Parish Office 347-7778	BETHLEHEM EVANGELICAL LUTHERAN CHURCH, ELCA "Let us go now to Bethlehem and see this thing that has taken place..." - Luke 2:15 35300 W 8 Mile, Farmington Hills, MI (248) 478-6520 (2 mi E of Haggerty N. side of 8 Mile) Sunday Morning Worship 8:30 & 10:45 AM Sunday School (All Ages) 9:30 AM
CHURCH OF THE HOLY FAMILY 24305 Meadowbrook Rd., Novi MI 48375 Masses Sat 5 pm, Sun 7:30 am 8:45 am, 10:30 am, 12:15 pm Holy Days: 9 am, 5:30 pm, 7:30 pm Fr. John G. Budde, Pastor Fr. Robert Stafek, Associate Pastor Parish Office 349-8847	OAK POINTE CHURCH At Novi High School 10 Mile & I-96 Roads Sunday 9:30 a.m. and 11:15 a.m. Casual, contemporary, live band (248) 912-0043 www.oakpointe.org
NATIVITY OF THE VIRGIN MARY GREEK ORTHODOX CHURCH 39851 Five Mile Rd (S & Haggerty) Plymouth, MI 48170 Phone 734-420-0131 Sunday Services Matins (Orthodox) 9:00 a.m., Liturgy 10:00 a.m. Rev. Fr. George M. Vaportis, Pastor www.nativitygochurch.org	CROSSPOINTE MEADOWS CHURCH Pastor Danny L. Langley Traditional Service - 9:00 A.M. Contemporary Service - 10:30 A.M. Meeting at Novi Civic Center 248-444-7755 crosspointemeadows.org
WARD EVANGELICAL PRESBYTERIAN CHURCH Dr. James N. McGuire, Senior Pastor 4000 Six Mile Road - Northville MI 248 374 7400 Morning Worship 9:00, 10:20 & 11:40 a.m. Sunday School & Nursery Provided No Evening Service July 2 www.wardchurch.org	CONG. BEIT KODESH 1-248-477-8974 31840 W Seven Mile Rd., Livonia Friday Night Services 8:00 p.m. Saturday Services 9:00 a.m. HIGH HOLIDAY SERVICES Sunday School 9:30 a.m. Sept-May

WHAT'S GOING ON? (CONT'D)

continued from 17A

TABLE TENNIS
 TIME/DAY: 6-10 p.m.,
 Monday and noon-4 p.m.,
 Saturday
 LOCATION: Hillside
 Recreation Center, 700 W.
 Baseline Road
 DETAILS: Eight tables are
 available. All skill levels are
 welcome. The cost is \$4 per
 day.

Regional

CITY OF PLYMOUTH
EVENTS
 CONTACT: www.ci.plymouth.mi.us
Music in the Air
 DATE: Friday through
 August
 TIME: 8-10 p.m.
 LOCATION: Downtown,
 Kellogg Park
 DETAILS: These concerts
 include musical entertainment
 for all ages. Families are
 encouraged to bring a picnic
 and seating.
 Fourth of July Parade

DATE: Tuesday, July 4
 TIME: 7:30 a.m.
 LOCATION: Downtown
 Art in the Park
 TIME/DATE: noon-8 p.m.,
 Friday, July 7; 10 a.m.-7 p.m.,
 Saturday, July 8; 10 a.m.-5 p.m.,
 Sunday, July 9
 LOCATION: Downtown
 DETAILS: This event will
 include 400 artists, live entertain-
 ment and food.
 CONTACT: (734) 454-1314

BORDERS-NOVI EVENTS
 LOCATION: 43075 Crescent
 Boulevard
 CONTACT: (248) 347-0780
Author Book-signing
 DATE: Tuesday, July 11
 TIME: 7 p.m.
 DETAILS: Author L.A. Banks
 will be reading, discussing and
 signing her new book, "The
 Forsaken."
Author Book-signing
 DATE: Tuesday, July 25
 TIME: 7 p.m.
 DETAILS: Author Gordon
 Castelnero will be discussing
 and signing his new book, "TV
 Land-Detroit."

ANGELA HOSPICE GROUPS
 DETAILS: Grief support
 groups include general grief,
 loss of a spouse, women's
 grief, heartstrings: parents
 who have lost a child and a
 grief support quilter's group.
 All groups are led by bereave-
 ment professionals and trained
 volunteers.
 LOCATION: Angela Hospice
 Care Center, 14100 Newburgh
 Road, Livonia
 CONTACT: Joan Lee, (734)
 953-6012

MASTER GARDENER
ASSOCIATION
 DAY: Second Thursday of
 every month
 TIME: 7 p.m.
 DETAILS: Meet at the
 Environmental Interpretive
 Center at the northwest corner
 of the University of Michigan-
 Dearborn campus, 4901
 Evergreen Road, between Ford
 Road and Michigan Avenue

PARKS PASS
 DETAILS: Metroparks and
 Oakland County Parks are
 offering a dual park pass. The

annual cost is \$43 and can be
 purchased at any park office.
 CONTACT: (800) 477-3178
 or www.metroparks.com

CRAFT SHOW
 DETAILS: South Lyon United
 Methodist Church on Pontiac
 Trail, is looking for partici-
 pants for this Nov. 4 event.
 The cost is \$35 per booth.
 CONTACT: Barb, (248) 437-
 0385 or Carol, (248) 437-2112

MOTHERS OF MULTIPLES
 DATE: Second Thursday of
 every month
 TIME: 7 p.m.
 LOCATION: Witch's Hat
 Depot, 300 Dorothy St., South
 Lyon
 DETAILS: Kensington Valley
 Mothers of Multiples provides
 information, support and
 social activities for mothers of
 multiple birth children and
 their families.
 CONTACT: Jackie, (248)
 437-5496



Photo by JOHN HEIDER/Northville Record

Artistic flair!
 Ward Presbyterian Church Vacation Bible School
 campers Meredith Biechle, 10, right, and Chloe
 MacDonald, 10, make a "story stick" during an arts and
 crafts segment of their week-long experience.

Plymouth
ROCK
 Landscape Supply
 & Garden Center

OPEN 7 DAYS!
 MON-FRI 7-7pm
 SAT 8-4 • SUN 10-3

Come see our
 vast display
 of flagstone
 and
 decorative
 stone

All
**TREES &
 SHRUBS**

20% OFF

Expires 7-30-06

Get Ready
 For Your BBQ...
PROPANE
 20 LB. TANK REFILL
\$11.00
 plus tax

With coupon • Exp. 7-15-06

We Also Carry:
 • Soils • Sands • Grass Seed • Brick Pavers
 • Garden Wall • Decorative Stone • Boulders • Mulch
 • Statuary • Ponds • Water Features • Fountains
 Patio and Pond Installation Also Available!

Delivery Available

Sale
 on
 American
 Flags

Brookside ^{Do It} Best Center

Huge 4th of July Sale • July 1st - July 5th

- Weber grills & accesories • propane services
- key cutting • screen repair

1021 Novi Rd. • North of 8 Mile
248-349-4488

Weber Grills Assembled & Delivered

bright house

Back by Popular Demand!
Now presents
Michigan 50's festival

July 26-29
Novi Town Center
 Where it all began!

**Classic Cars, Timeless Tunes, Food & Fun
 for Everyone at The Michigan's 50's Fest**

- AM 910 Radio Disney brought to you by LOC Federal Credit Union & Bright House Networks
- Petting farm, pony rides, art & scraps mobile, build your own sand castle, bike parade, 1st 200 kids - Free bike helmet (while supplies last)
- Vegas tent brought to you by Varsity Lincoln Mercury
- Friday Night Fireworks brought to you by Tom Holzer Ford, Shuman Chrysler Jeep and Varsity Lincoln Mercury.
- Friday Free Ice Cream Social brought to you by Cold Stone Creamery, Mrs' Field's, Michigan Milk Producers and Dunkin Donuts
- Saturday 19th Annual Car Show and Cruise brought to you by Varsity Lincoln Mercury
- Commercial and Crafts Exhibitors • Softball Tournament, SK Run

Entertainment Nightly by Bright House Networks

Wednesday - Sun Messengers - Free Admission
 Thursday - \$5 Steve King and The Dittilies
 Friday - \$10 Rocky and The Rollers • Fireworks at dusk
 Saturday - \$10 Gary Lewis & The Playboys w/Tribute to Jerry Lewis
 Opening Rocky and The Rollers
 18 under Free w/ adult

Visit www.michigan50sfestival.com or call 248.349.1950 for up to date schedules.

Novi News *Budweiser*

4.75% APY*

for balances of \$50,000 or more

**Choose a rate that makes more
 than a good first impression.**

The Key Ultra Money Market Savings Account

Pay on KeyBank for a premium rate that's well reliable

- Higher rates for higher balances
- This great rate is also available on business money market savings accounts
- Automatically eligible for our best full-featured checking package

Stop by any KeyCenter, call 1-888-KEY-1234 or visit Key.com today

KeyBank

*All annual percentage yields (APY) are accurate as of 6/24/2006 and are subject to change without notice. All interest rates and APYs for all balance tiers are variable and may change at any time after the account is opened. This is a tiered account. At any time interest rates and APYs offered within two or more consecutive tiers may be the same. When this is the case, multiple tiers will be shown as a single box. As of the date stated above, for Personal and Small Business accounts the APYs and minimum balances are as follows: \$01-\$24,999.99, APY is 0.10%; \$25,000.00-\$49,999.99, APY is 4.25%; \$50,000.00-\$99,999.99, APY is 4.75%; \$100,000+, APY is 4.75%. Requires minimum opening deposit of \$25,000.00 from funds not currently on deposit with KeyBank. Fees may reduce the earnings on this account. Public funds are not eligible for this offer. Key reserves the right to limit the sale of Ultra Money Market Savings accounts to small businesses with annual sales of \$10 million or less. Key.com is a federally registered service mark of KeyCorp. ©2006 KeyCorp. Member FDIC

4th of July

SUPER FUTON

SALE!

4th of July
Special Hours
10am-5pm

Sweet Dreams
Sweet Prices!



COMPLETE FUTONS
\$749
STARTING AT

It's a Sofa! It's a Bed! It's a Futon!

Perfect for your lake cottage, home, office, guest room, studio, recreation room, family room, basement and more!



\$219

All Steel Construction



\$199

All Steel Construction



\$169

Wood/Steel Construction

Valuable Coupons • Cut and Save!

<p>Mattress & Futon Shoppe</p> <p>\$100 OFF FUTON PACKAGES \$700 & Up</p> <p><small>Excludes all previous sales Expires 7-24-06</small></p>	<p>Mattress & Futon Shoppe</p> <p>\$50 OFF FUTON PACKAGES \$499 - \$699</p> <p><small>Excludes all previous sales Expires 7-24-06</small></p>	<p>Mattress & Futon Shoppe</p> <p>Replacement Futon Mattress</p> <p>10% OFF ANY IN-STOCK FULL or QUEEN SIZE ONLY</p> <p><small>Excludes all previous sales Expires 7-24-06</small></p>	<p>Mattress & Futon Shoppe</p> <p>Cotton Works Easy Care Futon Covers Reg. \$79.95 NOW \$49.95</p> <p><small>Excludes all previous sales Expires 7-24-06</small></p>
--	--	--	--



Visit us today...and discover the miracle of Tempur-Pedic!



Mattress & Futon Shoppe

Sweet Dreams • Sweet Prices!
mattressandfutonshoppe.com

ANN ARBOR	2131 W. Stadium (South of W. Stadium)	734.222.9472
CANTON	2249 Ford Rd. (At Hwy 10 In Canton Corner)	734.844.0400
BIRMINGHAM	3270 Woodward (1 block South of I-65)	248.549.1951
LAKESIDE	13909 Hall (Across from Lakeside Mall)	988.532.8055
LIVONIA	31629 Plymouth Road (1 block West of I-75)	734.425.1500
NOVI TOWN CENTER	(South of I-96)	248.348.5494
ROSEVILLE	3249 Grand (Across from Macomb Mall)	386.294.8360
ROYAL OAK	2074 N. Woodward (South of I-24)	248.414.6909
SOUTHGATE	17820 Eureka Road (Between Reek & Alton Rd)	734.281.7766
TAYLOR	22865 Ecorse (1/2 Mile East of Telegraph)	313.291.3603
TROY	3536 Rochester Road (Bet. Big Beaver & Watters)	248.743.1088
TAYLOR	23660 Eureka (Near Southland Mall)	734.287.0454
WARREN	26845 Hoover (In the Hoover - 11 Shopping Center)	586.754.1500
YPSI/ANN ARBOR	4563 Washtenaw (1/4 Mile E. of US-23)	734.975.9200

Developers 'open' up Seven Mile proposal

Former state hospital plans include open spaces — but is it enough?

Part of a series reviewing the development proposal for the 414-acre former Northville Psychiatric Hospital property.

By Tracy Mishler
RECORD STAFF WRITER

George Wesley and his wife, Carol, remember when trees and green could be seen for miles.

And though the couple knows times have changed since they moved to Northville in 1972, they hope some green will be preserved once the 28 buildings come down at the former Northville Psychiatric Hospital on Seven Mile Road.

"That property is one of the few natural areas left in Northville Township," George said. "If they're going to do anything with it, they should make it one big park for the community to enjoy."

Carol said strip malls and parking lots are not natural characteristics of the township.

"Everywhere you go, there's buildings and shopping," she said. "Soon there isn't going to be any green left if we keep allowing these builders to put up



these huge developments to draw more people to the area.

"We have enough people, and we have enough shopping."

Plans for the Highwood development, proposed three weeks ago by Bloomfield Hills-based Real Estate Interest Group, Inc. and Schostak Brothers, call for portions of the land to be left open or be donated as public space or township-owned property.

According to the developers, about 100 acres of the site has been proposed as open space for the development and more than 15 acres will be dedicated as a green belt for commercial and residential areas.

"Every community or subdivision needs its own fair amount of open space so people don't have

Living with open space

- Mid-rise apartments, lofts and condos: about 2.6 acres
- Town homes: about 3 acres
- Residential neighborhoods: about 26 acres
- Senior housing: about 1 acre

to drive to find trees and nature," said township Clerk Sue Hillebrand.

More than enough

Hillebrand said the planned unit development for the Seven Mile Property called for a minimum of 5 percent, or 20 acres of open space.

"It all depends on how they plan it," she said. "You can get pretty creative with open space."

According to plans submitted to the township, of five proposed Highwood neighborhoods, 15 percent of each neighborhood will be dedicated as open space for recreational use by its residents.

"This type of development, in terms of the quality that

Northville and Northville Township need, is keeping with the standards and also enhancing the area," said Linda Busse, director of corporate communications for Schostak Brothers.

Trustee Chris Roosen said he's scanned the plans submitted by Real Estate Interest Group and Schostak, but needs more details before he makes his mind up.

"There are two areas on that property of old growth forest that we would like to preserve," said Roosen. "They are attempting to do this in their plans, but we can't allow them to count the wetlands as part of their open space."

Details needed

Roosen said he is also interested in seeing plans for the proposed subdivisions in greater detail.

"I don't want to see a copy of Arcadia Ridge or Northville Ridge," he said. "I want less density and more open space."

According to the proposed plans, at the heart of the residential neighborhoods is a wooded 19-acre site for an elementary school.

"If there is a school site, that would help contribute to the feeling of open space," Hillebrand said. "The township's philosophy is to guard against

being overly dense ... Trees generate oxygen. We need trees."

Chip Snider said open space is a personal philosophy.

"Some communities are more dense than others," said the township manager. "Older cities are more dense than younger cities ... It's not about future growth (in Northville Township), it's about comfortability."

Tracy Mishler is a staff writer for the Northville Record. She can be reached at (248) 349-1700, ext. 107, or at tmishler@gannett.com.

'Promising' justice

Legal issues continue to loom in the shadows of the sale of the former Northville Psychiatric Hospital.

Michigan's Promise, a Lansing-based non-profit watchdog monitoring state government, continues to accuse the State of Michigan of not following the intent of law by selling the 414-acre site at a lower price.

According to state officials, the case was dismissed in May with a ruling from Ingham County Circuit Court Judge James Giddings, who found that Michigan's Promise did not have standing in court.

Former Speaker of the House Rick Johnson, representing Michigan's Promise, said the organization has filed an appeal with the Michigan Court of Appeals. "The State of Michigan and taxpayers are going to lose money if the court continues to rule in favor of the state," Johnson said. A date has not been determined for Michigan's Promise to appeal Giddings' ruling.

Candidate forum set for July 13

Voters eager to get a look at the crowded field in the race to replace term-limited state Rep. John Stewart, R-Plymouth Township, in the state House's 20th District get their chance July 13.

That's when the League of Women Voters of Northwest Wayne County, along with the Observer Newspapers, sponsors a two-part candidates' forum at Plymouth City Hall.

All eight candidates have been invited to participate. The five Republican challengers — Mark Abbo, Beth Stewart, Don Schmetter, Jason Vorva and T. Cortez Spann, Jr. — will face off at 7 p.m. in the Republican forum.

The forum for the three Democrats — Joanne Lamar, Joe Hawver and Marc Corriveau — starts shortly after 8 p.m.

The event will be taped for broadcast on local-access television several times before the Aug. 8 primary.

Candidates will be allowed a one-minute opening statement, one-minute responses to questions and a two-minute summation. The event will be moderated by a League of Women Voters member, who will read questions submitted by audience members.

The League of Women Voters is a non-partisan, political organization whose purpose is to promote political responsibility through informed and active participation of citizens in government. The League does not endorse or oppose candidates or parties, but it does work to obtain and distribute information to the public on candidates and their views.

Plymouth City Hall is located at 201 S. Main (at Church) in downtown Plymouth

SELLING A HOME

Homeowners, Realtors, Builders

Improve the appearance and marketability of your property with...

Total Home Enhancement

Interior and Exterior



Curb Appeal Sells, owned and operated by Todd's Services, Inc. has developed a proven program, designed to improve the interior and exterior appearance of your property, and increase its marketability, that will help you sell it faster and for more!

The program is simple — we provide the design, materials and installation of the required home improvement to enhance your residential, commercial or vacant property and **YOU DON'T PAY UNTIL YOU CLOSE**. Yes, you read that right...there is no up front, out of pocket expense to you until you close.

Let us show you the possibilities! Call to schedule a free consultation with one of our professionals and receive a free drawing/rendering and quote. Several financing options are available with approved credit. Ask rep for details.

Homeowners, Realtors, and Builders know a good first impression is key to selling homes. If you're trying to sell, we can help. Call today to see how our dedicated team of professionals can help you take full advantage of this fabulous opportunity to sell your property faster...and for more money.

Interior Home Improvement

- Paint
- Carpet
- Bath Remodeling
- Kitchen Remodeling
- Wallpaper Stripping
- Countertops
- Roofing
- Electrical
- Plumbing
- and much, much more!

Exterior Home Improvement

- Landscape Design & Installation
- Trees, Bushes and Shrubs
- Retaining Walls
- Hydro-Seeding & Sodding
- Sprinkler Systems
- Concrete Stamped Exposed egg & regular
- Brick Pavers
- Water Features
- Decks & Outdoor Structures
- Seawalls
- Remulching

Renovate We'll design and Re-Do install the entire project. Refresh You Don't Pay Restore Until You Close!



Call TS (810) 231-2778

Todd's Services **Guaranteed**

Todd's Services **Give Back to the Community**

CANTON CINEMA
Goodrich www.601.com
QUALITY THEATERS 734-924-FILM
Ford Rd 1 Mi W of I-275
All Stadium Seating All Digital Sound
No passes Free drink refill & 25¢ corn nibble
SHOWTIMES VALID 4:30 - 7:6

\$4.00 BARGAIN PRICE
4:30 - 6:00 PM

KIDS SUMMER MOVIES
Every Tuesday, Wednesday & Thursday at 11:30 am
\$1 ALL SEATS

LEMONY SNICKET (PG)

THE DEVIL WEARS PRADA (PG-13)
12:05 2:25 4:45 7:05 9:25

FR/SAT LS 11:45

SUPERMAN RETURNS (PG-13)
11:00, 12:00 2:05 3:05 5:10 6:10 8:15, 9:15

FR/SAT LS 11:20

CLICK (PG-13)
11:10, 11:50, 1:40, 2:20, 4:10, 4:50 6:40 7:20, 9:10, 9:50

FR/SAT LS 11:40

MACHO LIBRE (PG)
1:00, 3:00, 5:00, 7:10, 9:20

FR/SAT LS 11:30

CARS (G)
11:30 2:00, 4:30, 7:00, 9:30

COUPON
FREE 20oz DRINK
with \$20 purchase
of food (excl. of bakery products)
at participating locations only. Exp. 6/30/06

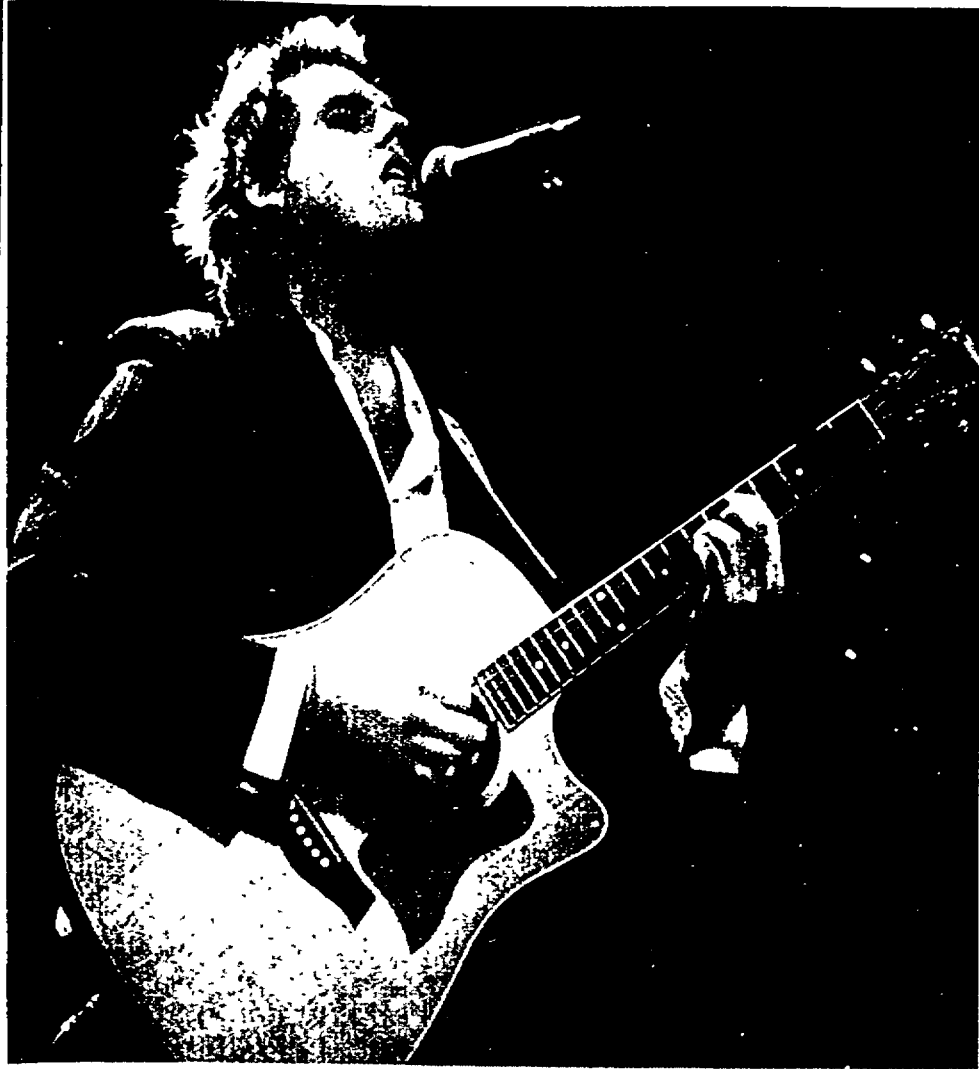

Making music!

Northville High School graduate Robin Horlock is ready to rock. Fronting The Robin Horlock Band, he and fellow band mates will launch their self-titled CD Friday, July 7 at the Magic Bag in Ferndale during a party hosted by radio personality Cal Cagno. The recording was produced by Marlon Young who has worked with Kid Rock and the Dave Matthews Band, and Horlock lists some of the EP's musical influences as John Mayer, Goo Goo Dolls, Oasis and Jack Johnson. The band line-up includes Robin Horlock as lead singer and guitar; Kenny Sams, lead guitar; Tom Sheppard, bass; Mike Vartanian, keys; and Ryan Hyland, drums. The Northville native also performs monthly at the Tuscan Cafe.

CHARTER TOWNSHIP OF NORTHVILLE NOTICE TO THE RESIDENTS A SPECIAL LAND USE PUBLIC HEARING

The Charter Township of Northville Planning Commission has scheduled a public hearing for Tuesday, July 25, 2006 at 7:30 P.M. at the Northville Township Municipal Office Building, located at 44405 Six Mile Road, Northville, MI 48168. The Planning Commission will consider Special Land Use requests for the property on the northeast corner of Sheldon and Five Mile Roads in Northville. The Special Land Uses include a retail center of approximately 68,000 square feet, a drive-thru bank and pharmacy; restaurants with outdoor seating, and outdoor sales associated with a fresh food market.

The public is invited to attend this hearing and provide their comments and ask questions. Written comments regarding the development proposal will be received by the Township Planning Commission, 44405 Six Mile Road, Northville, MI 48168.

GEORGE MCCARTHY, CHAIR
PLANNING COMMISSION

(6-29 & 7-20-06 NR 295111)



Family Fun Festival & Classic Car Show

PROCEEDS BENEFIT THE PLYMOUTH FOUNDATION

- Country Music 12-3
- Funkee Station 5-9
- Dunk Tank
- Bouncing Tent
- Face Painting
- Magic Shows
- Clowns

Classic Car Show 1-4
FREE lunch for all registered cars
1st Prize \$250!
To register contact Dan Tomei
734-788-8199

855 Starkweather • Plymouth 734-459-0885
www.station885.com

Food Tent, Beer Tent
Eat inside or outside

Picture Perfect Homes

Family Friendly
It's a dynamite combination: N. Beacon Woods sub (easy walk to downtown Northville) and this 4 BR, 2 1/2 BA, 2673 sq ft, charming, comfortable colonial on a lovely large lot. \$409,900.

Newer "Historic" Home
One look and you will be placing your furniture in this newer luxury home which has all the charm of yesteryear. No detail was left out: fab Kitchen, baths, trim, windows. W/o LL. \$719,900.

Country Setting, City Convenience
This spacious family home is only 1 mile from downtown Northville, on a beautiful 1 3/4 acre lot. Wonderful addition looks over gorgeous back yard. 1st flr Master, many extras. \$599,900.

Luxurious Bargain
For the square feet it is priced well below most homes in luxury Quail Ridge sub. Newer Kitchen w/granite, Sub-Zero. Lovely Sun Rm & FR, partial fin bsmt, many improvements. \$449,900.

Phyllis Lemon
Professional One Real Estate
248-640-7952 or 248-567-3500

AUTHORIZED **Pella** WINDOW AND DOOR REPLACEMENT DEALER

Beautiful. Affordable. Professionally installed.

- Quality windows, patio doors and entry doors to fit your style and budget
- Fiberglass composite
- We handle installation-start to finish

windows your way

sale 12 Months Same As Cash!

\$150 Off Any Pella Patio Door.

\$200 Off Any Order Of Three Pella Windows Or More.

15 YEAR LABOR WARRANTY

Call Adkins & Sons now to request a FREE in-home appointment.

Adkins & Sons
33555 Seven Mile Road, Livonia
(248) 471-0655
Family Owned & Operated

Come Visit Our Showroom!

JULY FOURTH SALE

20% - 50% Off
All Summer Merchandise

\$10.00 Off Any Sandal

With coupon only. Expires 7/15/06

Hershey's Too Comfort Shoes
(248) 347-7838 • 47750 Grand River • Novi
In the West Market Square at Beck Road between Kroger & Home Depot
Store Hours: Mon., - Sat. - 9:30 am - 6:00 pm

Great rates ... Easy terms.

13-MONTH CD
5.20% APY*

FREEDOM MONEY MARKET ACCOUNT
4.35% APY**
At the \$100,000 deposit level

AND EARN AN EASY EXTRA .25% APY.
Just for participating in our Loyalty Program. Ask us how.

*Annual Percentage Yield (APY) on 13-month CD is accurate as of 5/17/06. Minimum opening balance requirement is \$500 and maximum deposit is \$100,000. Penalty may be imposed for early withdrawal. Not available for public units. Account fees could reduce earnings. Other restrictions may apply. **Annual Percentage Yield (APY) is accurate as of 5/17/06. APY is 2.85% for balances of \$0-\$24,999; 3.10% for balances of \$25,000-\$49,999; 3.75% for balances of \$50,000-\$99,999. Account fees could reduce earnings. A fee of \$25 will be imposed every statement cycle in which the balance in the account falls below \$5,000 on any day of the cycle. Not available for businesses or public units. Rate may change after account is opened. Certain restrictions may apply. Please contact your local Flagstar branch for more information.

800 642-0039 www.flagstar.com

Flagstar Bank

Member FDIC Convenience you can count on



Chateau
Grand Traverse
Late Harvest
Reisling '05
\$14.49 750 ml
Sweet yet not sticky.
Try this with Joe's
Homemade Apple Pie.

Mas Carlot
Cuvee
Tradition
Syrah-Grenache '04
\$12.99 750 ml
Ruby colored with big
fruit flavors. Try this with
grilled Flank Steak.

**All of Us at Joe's Wish You a
Happy and Safe 4th of July!**

Always
a
Favorite!

Georgia
Sweet
Corn
10/\$2.00

California
Driscoll's
Raspberries
2/\$5.00

California
Driscoll's
Strawberries
\$1.69 lb.

Sweet
&
Juicy

Crisp
&
Sweet!

Michigan
Sweet
Blueberries
2/\$5.00

Joes
Pickles
2/\$6.00
All Varieties

Canadian
Tomatoes
On-the-Vine
\$1.29 lb.

Red
&
Ripe

Perfectly
Thirst
Quenching

Bitburger Beer
16.9 oz. cans
4 pk \$4.99 + Dep.
Case \$26.99 + Dep.
Crisp & Refreshing!

Italian
Fontina
Cheese
\$6.19 lb.
Delicate, Earthy-Herby Flavor

Mas Carlot
Cuvee Tradition
Marsanne Roussanne
\$12.99 750 ml
Full Flavored yet Light-Bodied White

Try This with
St. Andre
Cheese &
Crusty Bread!

Real
Crowd
Pleaser!!

Beringer
White Zinfandel
White Merlot
Pinot Grigio
\$4.99 750 ml

Mahon
Spanish Cow
Cheese
\$9.29 lb.
Rich, Creamy & Nutty Flavors!

Mas Carlot
Cuvee Tradition
Rose '04
\$11.99 750 ml
Tastes like a Rich Rhone Red with Subtle Tannin

A Perfect
Deck
Wine!

A
Summer
Favorite!

Joe's Fresh
Homemade
Key lime &
Strawberry Pies

Alouettes
Spreadable
Cheese
\$4.49 ea.
All Flavors!

Joe's
White Corn
Tortilla Chips
2/\$4.00

Great with
Chuck & Daves
Salsa!

A Variety Of
All Natural
Flavors!

Edy's
"A Family Favorite"
Ice Cream
2/\$6.00 56 oz. ctn.

Hoffman's
Super Sharp
Cheddar Cheese
\$3.99 lb.
Great Snacking Cheese!

Chuck & Daves
Salsa
\$2.99 each
16 oz. ctn.

Hot, Mild,
Mexican, Tropical
& Roasted
Tomato

Byrd's Choice Meats

July 4th Weekend Specials!

- | | |
|--|--|
| Ground Beef from Chuck (any amount).....\$1.89 lb. | Homeade Bunsie Sweet or Hot Italian Sausage.....\$2.39 lb. |
| Choice New York Strip Steaks.....\$9.89 lb. | Farm Raised Salmon Filets.....\$6.49 lb. |
| London Broil or Flank Steaks.....\$6.98 lb. | Sirloin or Chicken Shiskabobs.....\$5.89 ea. |
| Lean Center Cut Pork Chops.....\$3.69 lb. | Dearborn Skinless Franks.....\$1.98 lb. |

All Great on the Grill! Byrds Sunday Summer Hours 9-5

JOE'S PRODUCE

33152 W. Seven Mile • Livonia, MI 48152

www.joesproduce.com

(248) 477-4333

Holiday Store Hours: Friday, Saturday & Monday 9:00 am - 7:00 pm;
Sunday & Tuesday 9:00 am - 5:00 pm

Prices Good
Through 7/4/06

**OPEN
4TH OF
JULY**



Youth sports on fire

Northville is overflowing with youth athletic talent this summer, as several teams recently won tournaments and league titles.

— Page 3B

Regional Marketplace — Page 8B



Hungry?

There's always something cooking in the Northville Record's "In the Kitchen" section.

— Page 6B



RECORD SPORTS

www.northvillerecord.com

Thursday, June 29, 2006

NORTHVILLE RECORD, PAGE 11

HEART & 'SOL'



Photos By David Aguilar/Record Editor

George Lentz of Southfield joined runners and walkers in downtown Northville Saturday for the 2006 Solstice Run.

Solstice Run finish line reveals giant strides

One year ago, Danell Andersen looked out her Northville Township home with envy. And contempt.

She watched recreational runners slide by her home with ease, like tiny birds stopping by for a quick snack before fluttering into the warm summer air. One after another they beat a path in front of her home, relaxed and taut, moving to the beat a built-in metronome that kept them in rhythm, in stride and on pace.



David Aguilar
RECORD EDITOR



Runners prepare for the start of the 10K Solstice Run, shortly after 7:30 a.m. Saturday.

It was disgusting. Andersen watched in awe, like a child trying hard to figure out a magician's trick. But no matter how close she sat to the stage, she could never unravel the secret.

So one day she tried the trick herself, laced up a pair of running shoes and headed out. She could this! she told herself. Just put one foot in front of the other. She made it one block before

"Every time we drive it now, we will remember that we ran it once."

Danell Andersen
Resident, Northville Township

More race pics, Page 4&5B.

she quit. Winded. Heaving. Hurting. Must. Stop. Now. Before. Heart. EXPLODES!
Who was she kidding? the Class of 1975 Northville High

continued on 4B

They're back!

Veteran grid coaches return for JV program

By Sam Eggleston
RECORD SPORTS WRITER

Darrel Schumacher and Dennis Colligan just smiled when the topic of getting back in the saddle to coach again came up.

"It's going to be a lot of fun," said Colligan, who officially retires tomorrow as principal of Northville High School this summer. "You never really give it up. When you're watching games on TV or on a Friday night, you still feel that excitement."

This fall, the two former varsity head coaches will return to the Northville Mustangs football program as junior varsity coaches, running a West-Coast style built on the same offensive chassis as varsity head coach Ryan Hockman.

It'll be a change for the two coaches. The passing-heavy offense is a contrasting style to the ground-based program they both ran while at the helm.

"We're still learning," Colligan said. "It's a very sophisticated offense and we're

continued on 2B

History

Former head varsity football coaches Dennis Colligan (1977-1985) and Darrel Schumacher (1986-2001) return to the Northville grid-iron this fall when they take over the junior varsity Mustangs.

Schumacher retired from football to coach the boys basketball team in 2001 and was replaced by Clint Alexander (2002-04) and current coach Ryan Hockman (2005-current). During his time at the helm, Schumacher recorded a 74-80 record, making the playoffs five times.

Colligan stepped down from his post in 1985 to take the position of athletic director for Northville schools, a position he held for 10 years before being replaced by Larry Taylor (1995-2002) and Bryan Masi (2002-current). During his tenure as head football coach, Colligan recorded a 47-34 showing. His squads did not make a playoff appearance due to a different format than today's, which allows any team with six wins to automatically get a berth.

PLAYING NICE

Northville, Novi soccer players set aside state finals for club team

By Sam Eggleston
RECORD SPORTS WRITER

It could have been an ugly situation, but the girls from the Northville and Novi soccer teams took a deep breath, swallowed their rivalry and stepped out onto the field together.

Instead of opponents, they were teammates. Michigan Hawks.

The Northville Mustangs boast three players on the U17 Michigan Hawks squad that, once again, is competing in the regional tournament after winning a state club soccer title. The regional, held in Appleton, Wis., will determine which club team goes to the national tournament, held in Iowa this year.

"(The state final) wasn't an issue at all," said Novi forward Stephanie Crawford. "We just went out there and practiced like we normally do. We were teammates again. We were friends."

Despite Novi edging their cross-town rivals Northville, 3-1, in the Division I state finals June 17, the representatives of the two squads put it behind them and got to work. The Hawks, considered one of the

"We just went out there and practiced like we normally do. We were teammates again. We were friends."

Stephanie Crawford
Michigan Hawks

top club programs in the state, had a single goal in mind with a regional title in their sites. If they win the regional tournament, which was still being played at press time, it will be their third straight.

"That would be great," said Northville junior Kristen Slack, who plays midfield and defense for the club. "This is a great team. We have a lot of really talented players."

A lot of big names, too. Novi's representatives are Crawford, Emily Esbrook, Kristine Chaklos and Jessica Barndt. Northville's are Slack, Vanessa Bailey and Dani Toney. Of the seven, four were All-

continued on 2B

East takes All-Star softball win

Northville players help 9-0 victory

By Sam Eggleston
RECORD SPORTS WRITER

Audrey Sabourin stepped into the pitch and made solid contact, firing the ball out of the infield and driving in three runs to give her team a major advantage.

And that was the third inning. Sabourin, a Lakeland High School softball standout, joined seniors from Novi, Northville and Milford to form the East team in the annual East-West All-Star softball game last Tuesday. When the dust settled at Pinckney High School, the East toppled the West, 9-0.

The West team was made of players from Brighton, Howell, Hartland, Fowlerville and Pinckney.

"It was a lot of fun," Sabourin said after the game. "I really think it was a great way to end our high school careers."

Sabourin, who normally patrols the field as a shortstop, played catcher for the East and handled the task of snagging pitches from hurler Jessica Wojcik, of Milford. Wojcik allowed just two hits and walked one while striking out nine batters.

"I'm really glad I was able to play," Wojcik said. "Getting a chance to play with girls who I normally play against was a lot of fun."

The East took a 2-0 lead in the first inning when Northville's Bridget Hughes and Sabourin crossed the plate on a hit by Novi's



Photo by SAM EGGLESTON/Record Sports

continued on 2B Laura Zima inches away from first base.

Six numbers you should know about the Northville Mustangs ...

9

Runs scored by the East All-Star softball team in last week's contest.

0

Number of runs scored by the All-Star squad from the West.

4

Total players on the U17 Michigan Hawks squad from Novi High School.

3

The number of U17 Hawks players who represent Northville High School.

121

Combined wins Dennis Colligan and Darrel Schumacher earned as head coaches.

114

Number of combined losses amassed by the two coaches during the 1977-2001 seasons.

YOUTH SPORTS EARN BIG VICTORIES



Submitted Photo

Congratulations U14 Broncos

The U14 Northville Broncos won the June 2006 Frankenmuth Tournament in their third tournament trip to the semifinals and finals for the team. They have been victorious for both the Clarkston and Frankenmuth tournaments and were runners-up for the Canton Tournament. The team and their father's posed for the Father's Day Frankenmuth victory picture. The team said thanks to all the dad's for all they do for the team and their support. Team Members and fathers are (left to right): first row: Coach Terry Mills, Dan Mills, Coach Rick Montgomery, Daven Montgomery; second row: Ryan Sherry, Robby Buschbacher, Jonathan Savakus, Marc Zughaib, Dan Flowers, Ron Flowers, Anthony Capatina, Gene Capatina; third row: Jerry Sherry, Ryan Liening, Mike Leining, Chris Buschbacher, Trevor Grigg, Hal Savakus, Ed Grigg, Kevin Andrews, Kevin Andrews Sr. and Marcel Zughaib.



Submitted Photo

G-League Champions!

The Mets baseball team, part of Northville's G-League, earned a championship win over the Cubs in the bottom of the sixth inning, 4-3. The team includes (from left to right): First row: Eric Ripper, Kyle Skillman, Alex Coe, Alex Agne, Antony Manchesky, Aaron Kosmowski, Tim Harrell; back row: Head Coach Adam Coe, Nate Lightner, Forrest Ickes, Austin Lightner, Jake Widmer, Ryan O'Callaghan, Jacob Bates, Assistant Coach Scott Manchesky.

Want to see your team in the Northville Record? E-mail the sports department at seggleston@gannett.com!



Submitted Photo

Broncos win!

The U8 Northville Bronco's Travel Baseball team won third place at their first tournament of the season when they competed in the Elba Little League Summer Tournament. Pictured are: front row: Joshua Gertley, Bradley Huth, David Weber, Willie Yanagi, Peter Blust; second row: Coach Jeff Gertley, Zachary Prystash, Alex Putman, Dominick Montone, Nicholas Wilds, Paul Steffes, Michael Townsend and Coach Mike Putman. Not pictured: Kevin O'Connell.



Submitted Photo

Premier soccer showcases talent

Northville Premier Soccer showed just how bright soccer's future is when they earned some tough wins recently. The team includes: top row (left to right): Coach Tony Deacon, John Hatzis, Christopher Long, Brian Finley, Bobby Laski, Nathan Hrivnak; middle row: Edwin David, Max Wujczyk, Cameron Burdette, John Donikian, Arthur Huerta; bottom row: Trenton Buycks, Joshua Pascarella, Michael Simms, Nick Kristock, Alec Iwasko and Scott Santoro; not pictured: James Dutcher.

Please send the photo as a jpeg image, include the team name and identify the players in the photo.



Submitted Photo

Pizza Cutter champions

Taking a championship isn't easy, especially in Northville's tough H-League. Pictured are the Pizza Cutter champions: front row: John Lippert, Grant Dixon, Connor Manross, Troy McManus, Rob Stonik, Nick Mardeusz; second row: Tim Eis, Michael Conder, Robby Parks, Alex Stellen, Adam Pond, Jack Rathsburg; back row: Coaches Todd Eis, Dan Parks and Paul Mardeusz.



Submitted Photo

Victorious Cougars

The Novi Cougars Squirt B team wrapped up a successful 2005-06 hockey season by capturing the Novi House tournament championship in a thrilling 14-overtime victory over the Novi Wildcats, 1-0. After losing the first game of the double elimination play-off, the Cougars rattled off six straight wins including two that ended in shootouts. The Cougars finished the season with a 42-13-2 record, which also included winning the Little Caesars Squirt Division 7 regular season title and the Brad Stone tournament championship along with trips to the District 4 and Little Caesars quarterfinals. Team members are: Jal Sura, Mark Czapski, Taylor Turner, Anton Marinelli, Sean McDonnell, Jake Lennard, Nick Gasparotto, Bobby Witkowski, Cameron Gromek, Zachary Stanley, Jacob Zadorozny, Trevor Malarkey, Alex Turner, Christian Schneider, John Steffes and goalie Blair Myers. The Cougars were coached by Chris Steffes, Gary Myers, Jeff Zadorozny and Tom Malarkey.

Runners, make your mark!



Northville Township residents Mellanee Asher, 38, left, and Danell Andersen, 46, enjoy a few laughs after they crossed the finished line Saturday morning during the 10K Solstice Walk/Run. The annual event also featured a 5K Walk/Run.

Photos by DAVID AGUILAR/Record Editor

SOLSTICE: finish line reveals distance traveled

continued from 1B

School graduate mumbled to herself as she headed home, discouraged. After all, she had never been a runner, so what made her think that starting in her mid-40s was a good idea?

"It was awful," Andersen said Saturday morning, moments after crossing the Solstice Run 10K finish line at Ford Field, the final destination for a race that began promptly at 7:30 a.m. in the middle of Main Street, took a quick left at Center Street and headed for the hills of Hines Drive before returning runners downtown, wearing the faces of children who'd been spanked and sent to their rooms to "think about what they'd done."

Andersen, 46, finished last in her female 45-49 age group, needing 1:13:01 to complete the course. Of 10 runners in her competitive division, nine finished before her. And

of the 450 overall 10K runners, Andersen finished 443.

The overall winner finished the course in 29 minutes, 17 seconds.

Andersen's time was hardly noteworthy. But she finished, alongside good friend and Ford Motor Co. co-worker Mellanee Asher, 38, who for the past year has been encouraging Andersen to keep at it, training with her whenever their schedules allowed.

Why do it?

Andersen began running last October, motivated by a friend who had been diagnosed with breast cancer. On her behalf, she ran the Race for the Cure, an annual event benefiting the Susan G. Komen Breast Cancer Foundation.

She raised \$4,000. Since then, Andersen and Asher established a three to four-day running regimen, amassing about 16 miles weekly.

"A year ago, running a race like this was just a dream," Andersen said while standing beside Asher, participants' medals dangling from their necks. She credited Asher with being a dedicated coach, a personal mentor and a good enough friend to sacrifice her own personal performance — and likely a much better finishing time — just to stay by her side during the entire race.

"She runs slow just for me," Andersen said. "I never, ever imagined I could run six miles ... but I did it."

Asher shook off notions of self-sacrifice, but bristled when someone reminded her the two finished near the end of the line. "It just feels good to finish," she said. "But every time someone would pass us ... it was kind of hard to take."

Someone asked how they liked the course, a herky-jerky trail that at one point wended past their own homes. Asher, a mother of two kids

who has run a few races on her own, including a marathon a few years back, was enthusiastic. "I loved the course. It was great," she said, before getting cut off by Andersen.

"What do you mean it was great?" Andersen said, noting the steeply-inclined Hines Drive portion of the early course. "It was hilly!"

Still, pain is not without its enduring pleasure. "Every time we drive it now, we will remember that we ran it once," Andersen said, who a year ago couldn't run a single block without heaving and having to stop. Things are different now.

At the finish line, seven runners removed from dead last, it's sometimes difficult to tell the winners from the losers.

David Aguilar is the Northville Record editor. He can be reached at (248) 349-1700, ext. 102. Or by e-mail at daguilar@gannett.com.

COLOR REPRINTS • (248) 349-1700



Stephanie Johnson of Clawson walks the 10K course.



2006 Solstice Run



Northville resident Sean McCullough, 9, races for the 5K finish line.



Novi resident Debra Davis heads for Ford Field.



Carl Fontana of Bloomfield Hills turns on Hutton Street, heading for home.



Northville resident Kristen Gajda heads for the finish line at Ford Field.



Northville resident Laura Stewart, left, runs alongside Williamston resident Cheryl Hansen.



Phil Gruenhagen of Canton passes Center Street as he heads for the final leg of the 2006 Solstice Run.



For complete Solstice Run race results, visit www.solsticerun.org

IN THE KITCHEN

A Family AFFAIR



Ginger and Hot
Pepper Prawns and Grilled
Salmon and Crème Fraîche Pizza

FAMILY FEATURES

The game of golf took Greg Norman around the world, and he returned home with more than 91 professional titles. Greg's travels also ignited a passion for wine and a sense of culinary adventure that he has always enjoyed sharing with his tight-knit family.

In those early years, whenever the family traveled with Greg, he encouraged his children to experience local culture, introducing them to sometimes exotic regional cuisine. These experiences made a lasting impression on his daughter, Morgan-Leigh, who now shares her father's passion for great food and wine.

"Most kids aren't very adventurous eaters, but in our family Dad always encouraged us to try different things in order to decide if we liked them," Morgan-Leigh says of her father. She soon learned to trust her own palate, and further honed her culinary skills by cooking with her mother, Laura. Over time she became especially intrigued with the intricacies of food and wine pairing and began her formal training by studying in Florence, Italy. She's now enrolled at a top culinary school in the U.S. and plans to become a food and wine educator.

As for Greg, he became so fascinated by wine that he created Greg Norman Estates in 1999. The initial collection included wines from his native Australia, which quickly won critical acclaim.

Today the Greg Norman Estates portfolio also includes varietals from some of California's best viticultural regions. Although his reputation as a vintner is now well established, Greg remains relaxed and open in his approach.

"Experimenting with different varietals from diverse regions is a necessity and really the only way to truly understand what flavors and qualities you prefer," he says.

What started as an adventurous streak has turned into a Norman family tradition. These days Greg can often be found sampling Morgan-Leigh's creations, such as the Ginger and Hot Pepper Prawns and the Grilled Salmon and Crème Fraîche Pizza recipes below.

"When your children become adults and develop their own interests, you cherish every opportunity to spend time with them," says Greg. "Food and wine pairing is a great way to spark lively debate and bring our family together."

Ginger and Hot Pepper Prawns

Prep time: 20 minutes
Marinate time: 30 minutes
Cook time: 6 to 10 minutes

- 16 very large prawns
- 2 tablespoons rice vinegar
- 2 tablespoons olive oil
- 1 tablespoon chopped fresh cilantro
- 1/2 tablespoon minced fresh ginger
- 1 medium-size hot pepper (red or green jalapeño), stemmed, seeded and minced
- 1 large clove garlic, minced

Rinse prawns and pat dry; remove shells, leaving tails on. To butterfly, carefully cut along curved edge of each prawn, cutting almost all the way through. Thread 2 skewers through each prawn, putting 2 prawns on each set of skewers. (This helps keep prawns from turning on skewers.) Place in shallow dish. Stir together remaining ingredients and pour over prawns, covering well. Marinate 30 minutes, then cook over hot coals 3 to 5 minutes on each side, or until prawns are very pink. Makes 4 appetizer servings.

Bacon-Wrapped Tenderloins With Marinated Portabellas and Blue Cheese

Prep time: 30 minutes
Marinate time: 1 hour to overnight
Cook time: 10 to 15 minutes

- 1 cup balsamic vinegar
- 1/4 cup extra virgin olive oil
- 4 cloves garlic, minced
- 2 teaspoons cracked pepper
- 1 teaspoon salt
- 4 (6-ounce) beef tenderloin steaks
- 4 strips center-cut bacon
- 4 portabella mushroom caps, cut into 1-inch slices
- 2 ounces blue cheese, crumbled
- Chopped fresh rosemary or Italian parsley

Place vinegar, oil, garlic, pepper and salt in small bowl. Divide mixture into 2 large resealable bags. Place steaks in 1 bag and set other aside. Seal bags and refrigerate steaks at least 1 hour, or up to 24 hours. Place mushroom slices in reserved bag of marinade 30 minutes before cooking.

When ready to cook, remove steaks from marinade and wrap 1 bacon strip around edge of each, securing with toothpicks. Cook beef and mushrooms on grill over medium coals about 5 minutes on each side, or until beef reaches desired doneness, making sure bacon is fully cooked. (Steaks will be medium-rare at this point.)

Turn off grill and top steaks with blue cheese. Cover grill and let stand until cheese has melted. Serve steaks over mushrooms, garnished with fresh herbs. Makes 4 servings.

Greg Norman and his daughter Morgan-Leigh



MENU matches

Here are Greg's recommendations for pairing with his daughter's menu. For the full menu, recipes and additional wine suggestions go to www.shark.com/gneates.

2004 Santa Barbara Chardonnay — Crisp apple, and tropical fruit flavors layered with creamy vanilla and nuances of toasty oak.

2003 Lake County Zinfandel — Flavors of blackberry and raspberry with hints of spice and a long, elegant finish.

2004 Limestone Coast Shiraz — Ripe blackberry and cassis flavors with notes of pie spice, eucalyptus and coffee.

2003 Limestone Coast Cabernet Sauvignon Merlot — Rich berry and black plum fruit flavors with supple tannin and a silky mouthfeel.

Grilled Salmon and Crème Fraîche Pizza

Prep time: 20 minutes
Cook time: 10 minutes

- 1 pound pizza dough
- 1 tablespoon extra virgin olive oil
- Salt and freshly ground pepper to taste
- 2/3 cup crème fraîche (about 8 ounces)
- 8 ounces thinly sliced smoked salmon
- 1/4 red small onion, very thinly sliced
- 1 to 2 tablespoons tiny fresh dill sprigs

Divide pizza dough in half. Roll into 9-inch circles on lightly floured board. (The thinner the dough, the crisper the pizza.) Brush each side lightly with oil and sprinkle with salt and pepper. Carefully place dough on grill over medium-hot coals. Grill about 10 minutes, turning several times, until dough is cooked through and lightly charred; remove from grill and let cool.

Lightly spread crusts with equal amounts of crème fraîche, leaving 1/2-inch border around edge. Top with slices of salmon and sprinkle with onion and dill. Cut into small wedges and serve with lemon wedges. Makes 6 to 8 appetizer servings.

HEALTH

Family fitness goals help get 'em off the couch

By Barb Berggoetz
Gannett News Service

Remember spending all day playing outside in the summer?

Kids hopped on bikes, went from house to house, played four square, freeze tag or dodge ball, jumped rope or shot baskets — and then hit the pool.

In this age of Xbox and computer games, iPods and widescreen TVs, though, fitness experts say it's more crucial than ever that parents make sure children aren't glued to the couch over summer.

Easier said than done. But there are hundreds of new and traditional games and activities that youth can play with friends, beside such stand-bys as bike riding, swimming and skateboarding.

Better yet, parents should join in. "If they see you, even if you are just facilitating the activity, that's

good," says Anne Graves, program coordinator for Committed to Kids, a fitness and nutrition program of Clarian Health Partners in Indianapolis. "They live by example."

Recent research shows a direct link between kids' weight and the amount of time they spend in recreational physical activity, not with friends, but with families, says Dr. Caroline Cederquist, columnist and bariatric physician in Naples, Fla. She wrote "Helping Your Overweight Child — A Family Guide" (Advance Medical Press, \$14.95).

Activities, fitness specialists say, can be as simple as playing Frisbee, tossing a baseball, having a water balloon fight or taking a family walk or jog.

The Centers for Disease Control and Prevention recommends 60 minutes of daily moderate activity

for youth. But its research found more than 60 percent of 9- to 13-year-olds don't participate in any organized physical activity outside of school hours, and a quarter don't engage in any free-time physical activity.

Athletic and competitive youth more likely will be active on their own, but some children, especially those who aren't athletic, or who shy from competition, need more motivation.

For all, activities have to be fun and suited to kids' interests and abilities.

"If it's not fun, they're not going to want to do it," advises Audrey Satterblom, a school wellness director.

Youth need to see improvement, help decide on family activities and perhaps get some recognition or reward, like an active toy or small trip. It's a good idea to set fitness

goals, such as biking for a half-hour or doing 50 sit-ups, for kids.

"If you set a bar, many kids are going to be motivated to hit that bar," Satterblom says.

Families can set a daily fitness hour and decide on Sunday what to do the next week.

"Plan for it. Otherwise, it just doesn't happen," says dietitian Amy Moyer.

Whatever parents and youth decide to do, author Michael Pastore of Ithaca, N.Y., says play is vital for children physically, socially and developmentally.

"It defines childhood and what makes childhood special," says Pastore, who wrote "Kids Play Games: 101 Active Games for Cool Kids" (Zorba Press, \$16). "It's the way they understand the world, and it gives them their special place."

10 Ideas to motivate your kids to stay active

1. Create a friendly competition between parents and children to reach certain daily or weekly fitness goals - number of push-ups or steps walked, minutes of running.
2. Let your child be your personal trainer and you can be your child's trainer - count repetitions, time exercises, track progress.
3. Plan daily fitness activities on Sunday night for the coming week and reserve a specific hour every night to do them.
4. Involve child in decision-making regarding choices of family fitness activities.
5. Set realistic fitness goals for your child - and yourself - and raise the bar once they reach them. Post them in a prominent spot like the refrigerator.
6. Reward your child when he or she meets fitness goals for a week or month with quality parent time, an active toy, fun activity or short trip - not food.
7. Make fitness activities fun, not drudgery - obstacle courses, water balloon fights, treasure hunts during walks.
8. Suggest a variety of activities-games for your child and try them out. Help your child find a "fitness" niche, based on interests, abilities and body type.
9. Set up play dates or get-togethers involving neighborhood children or friends and organize active games or fun competitions.
10. Choose fitness-oriented gifts - a jump rope, mini-trampoline, tennis racket, baseball bat, youth membership at the local Y.

From traditional to new, games for the entire family

Traditional favorites

Red light-green light: One person plays the "stoplight," facing away from the rest, standing 15 feet away. When the stoplight says "green light," everyone moves forward, trying to touch the stoplight. When the stoplight says "red light," he turns and anyone caught moving is out. He wins if everyone is out before touching him. Otherwise, the first player to touch him wins and becomes the stoplight.

Annie Annie Over: Two teams get on either side of a house. One player from a team throws a rubber ball over the house. If a player from the other team catches the ball before it bounces, the team runs to the other side with the ball. If the player who caught the ball touches or hits an opposing team player with the ball before he reaches the other side, the player changes teams. If the ball is caught after it bounces, players can't chase the other team. Then they throw the ball back over the house.

Four square: Draw four 8-foot-by-8-foot squares, making a larger square. Each player occupies one 8-foot square. The squares each have a rank order. One player serves a kickball by bouncing it in his square once and hitting it toward another square.

The receiving player hits the ball to any other player. Play continues until a player hits the ball or is hit by the ball before it bounces once in his square, or a player does not hit the ball before it bounces twice, or a player hits the ball out of bounds. Once a player is "dead," he moves to the lowest-ranking square, or another player takes his place.

Kids' favorites

Capture the flag: Played on a soccer-sized field, the object is to defend your team's flag (bandana or cloth) and also grab the opposing team's flag in its territory and run back without being tagged. Players are safe from capture on their own side, but can be captured across the midline if an opposing player pulls out their flag belt. Each team has a jail and a flag, both located anywhere in its territory that's at least 10 yards from a boundary. A player can get out of jail if a teammate tags him. A round ends when a player returns with the opposing team's flag and touches his own flag.

Scavenger hunts: Hide clues around the yard, directing each person to the next clue by describing a landmark or object. Children

and adults can work in teams or individually to see who gets done first. The winner can create the next game or get a prize.

Obstacle course-boot camp: Set up a course in the backyard, using buckets, pans, trees, balls, old tires, hoses - anything to crawl through, under, over, around or jump on. Or set up a boot camp, with stations for jumping jacks, push-ups and wall squats. Host a neighborhood Olympic day with similar events for parents and kids; the winning family gets a prize.

Game of chance: Write names of activities, such as running around the yard, to the swing set or down the driveway, on slips of paper. Fill out other slips with movements, such as doing the crab, elephant or gorilla walk, galloping or hopping. Put each activity in one bowl and each movement in another. Each person pulls one slip out of each bowl and combines the activity and movement - hopping around the "house" or skipping down the driveway.

Creative games

Generate an unusual game related to a sport with the Game Generator at www.verbnow.com created by the Centers for Disease Control and Prevention. Some are:

Yard basket Frisbee: Grab a Frisbee and make a basket out of anything in the yard (tree stump, pile of leaves, rock). Assign certain spots to be two-, three- and four-point areas. Try to hit the baskets from those spots. If you're on defense, you can block throws and knock the Frisbee down. First one to score 25 points wins.

Yard volleyball: Set up a volleyball game, but replace the ball with a beanbag. You can use your hands, feet or whatever you want to get the bag over the net. First team to score 15 points wins.

Playground footbase: Place four bases on the playground to form a baseball diamond. From home plate, punt a football to anywhere on the playground. If it's caught, you're out. If not, run the bases like regular baseball. If you hit a home run, perform a touch-down dance.

From Michael Pastore's "Kids Play Games: 101 Active Games for Cool Kids"

Spring tag: Team captains pick two teams. Each team selects a base, where they are safe from capture, and a jail to put prisoners in. Team A chases team B and tries to capture them by tagging them and shouting, "7-8-9, you are

Steps youth can take to stay active in summer

- Start an activity log during the summer (track progress online at www.presidentschallenge.org and win medals) and set goals for yourself.
- Use a pedometer to count steps between your favorite places (for instance, house and park).
- Practice dance moves to music, invent some new ones.
- See how long you can hop on one foot, jump rope, do jumping jacks or other fun exercises and try to increase your times over the summer.
- Do sprints or short runs in the neighborhood; keep record of your times; go on longer runs if you're able.
- Work in the family garden (visit kidsgardening.com for ideas).
- Wash your parents' or neighbors' cars.
- Organize badminton, volleyball, basketball, capture the flag or other games weekly with friends.
- Suggest active family vacations or weekend trips that include hiking, canoeing, swimming, biking.

Sources: www.kidshealth.org; www.shapeup.org; American Heart Association; Audrey Satterblom, Indianapolis Public Schools wellness director; Amy Moyer, Indiana Action for Healthy Kids chairman

mine." Captured prisoners are brought to the jail, but can be freed if a team member touches the jail and shouts, "1-2-3, you are free" without being tagged. After a while, or when one whole team is captured, let team B chase and team A run away.

Knockout basketball: Play on half of a basketball court with two basketballs. All players stand in a line behind the foul line. Players shoot fouls to determine who goes first. Give the first two players basketballs at the foul line. The first

player shoots. Immediately after the ball leaves his hands, the second player shoots a foul shot. The object is to score a basket before the player behind you scores. If you do, you are safe for that round. Then you pass the ball to the next player and run to the back of the line. If the player behind you scores before you do, you are eliminated. If you miss your shot, you run to get your ball and shoot again from that spot (or a layup for younger players) before the next player makes a basket.

SOUTHEAST MICHIGAN'S NEW

PROFESSIONAL INDOOR SOCCER TEAM



Full-Time/Part-Time Positions Available:

- Sales Executives
- Equipment Manager
- Club Seat Servers
- Stats Crew
- Scoreboard Operator
- Time Keeper
- Mascot

For more information call 1.888.436.GOAL (4625)
www.detroitignition.com

PRESENTING



PARTNERS



Home Owners...

Are your Smoke Alarms and Carbon Monoxide Detectors Operational? Do you have them in your home?

Smoke alarms are an incredible success story. When this new concept won popularity in the 1970s, it wasn't long before the fire death rate was cut in half. Now, more than three decades later, most homes have at least one smoke alarm. However, we still have a problem.

In one quarter of the homes with smoke alarms, the alarms don't work. The cause is missing or dead and/or disconnected batteries. Pillar To Post® would like to encourage you to maintain your smoke alarms in an operational state. The same is true for carbon monoxide detectors.

The Benefits of Smoke Alarms

To Wake You: If a fire breaks out while you are asleep, you might expect the smoke and flames to wake you up, but it does not. You cannot sense the smoke while you are asleep. The fact is, you will not wake up. This is the main reason we have smoke alarms.



Randall Patterson

Early Warning: There is another key benefit of smoke alarms: early warning. The sooner you know you have a fire, the better the outcome. For a minor fire, early warning may make the difference between quick containment and a fire that is out of control. For a bigger fire, early warning could make the difference between minor damage and complete loss of your home.

The Benefits of Carbon Monoxide Detectors

To Wake You: If a gas furnace or hot water tank should release carbon monoxide while you are sleeping, the alarm will wake you and allow you to get your family safely out of the home. Stay out of the house and call a heating professional to inspect. Do not enter the house until the home can be verified that it is safe to re-enter.

Smoke Alarms

- Here are the general guidelines:
- There should be at least one smoke alarm per floor including the basement.
- Many authorities suggest an alarm in each bedroom.
- The alarm can be placed on the ceiling or high up on the wall.
- If the alarm is on the ceiling, it should be at least four inches away from any walls.
- If the alarm is on the wall, it should be at least four inches but not more than twelve inches from the ceiling.
- Peaked ceilings have stagnant air at the top. The smoke alarm should be three feet from the highest point.
- Do not place the smoke alarm where it could be affected by drafts such as near a window or air vent.
- Follow the installation instructions provided with the smoke alarm.

Carbon Monoxide Alarms

- There should be one carbon monoxide detector in each sleeping area and the main living area of the home.
- Installed carbon monoxide detectors as described by the manufacturer.

Types of Smoke Alarms

There are two different types of smoke alarms: photoelectric and ionization. Photoelectric smoke alarms are slightly better at detecting smoldering fires such as from a cigarette burning on a couch whereas an ionization type is slightly better at detecting flaming fires such as burning paper. In the past, this generated much discussion about which one was better. The fact is they are both good and that the difference is insignificant. Both must pass the same certification requirements for all types of fires.

Maintaining

- Smoke and carbon monoxide detectors require very little maintenance.
- Test the alarm once per month by pressing the test button until the alarm sounds, then release the button.
- If the smoke alarm is battery operated, replace the battery every year.
- If you hear a chirping sound from the smoke alarm, it identifies the battery is weak and requires replacement. Charge the batteries.
- Dust or vacuum the surface of the alarm periodically.
- Replace the entire unit if it is older than 10 years or if you are not sure how old it is.
- Print the installation date inside the cover.

False alarms

Nuisance tripping of your smoke alarm is bound to happen occasionally. For example, smoke from the stove could trip the alarm. Unfortunately, many people remove the batteries to silence the alarm with the good intention of replacing it after the smoke clears. This is one of the most common causes of non-functioning smoke alarms.

Here are some better ways to deal with nuisance tripping:

- Move the smoke alarm a little further from the kitchen area.
- Try a different type of alarm. Some experts say that a photoelectric smoke alarm is a little less sensitive to common causes of false alarms.

Hard wired alarms

Many homes today have smoke alarms wired right into the household electrical system. There are two benefits:

- The alarm is powered from the electrical system. Many also have a battery back-up so the alarm operates even if there is a power outage. These should also be replaced yearly.
- You can have the alarm interlocked. This means if one alarm in the home sounds then the others sound as well. This is a big advantage. For example, if there is a fire in the basement, you may not hear a smoke alarm sounding from two floors away while you are asleep. If the alarm is interlocked, the alarm in the basement will trigger all of the alarms in the home.

Escape plan

Smoke flame and carbon monoxide can spread quickly so you need to react quickly. It is vital that you and your family know what to do on hearing an alarm. You should plan an escape route from every area of the home and identify a safe area to meet outside the home. You should rehearse the escape plan with your family. Walk through and identify obstacles that may slow you down such as windows that are jammed or exits that are crowded with storage etc.

Home owners should understand that these are just a few recommendations to help keep your family safe from fire and carbon monoxide.

Call us to have your home checked and identify any safety issues.

Randall Patterson
Certified Pillar To Post®
NAIHC-CRI Home Inspector
Toll Free: 800-787-3680
Direct: (248) 755-3422



For additional information please visit our web site at www.piphome.com or www.kestaklandliving.com

- We also provide the following Environmental Testing Services:
- Radon Testing
 - Mold Evaluation
 - Asbestos Sampling
 - Water & Air Quality Testing
 - Pest Inspections
 - Well & Septic Inspections
 - Home Energy Surveys
 - Custom Inspections for any areas of your home

ADVERTISEMENT

ADVERTISEMENT



Photos by HAL GOULD/Gannett/News Services

The Hidden Lake residential development, located in Green Oak Township, offers a unique lifestyle for families of all ages and sizes.

Hidden Lake: home, at last

Residential community offers unique flair

By Annette Jaworski
SPECIAL WRITER

It could be the gentle waves lapping near the marina, or the six miles of paved walking paths. Maybe it's the lush landscaping dotted with formal gardens and waterfalls that make Hidden Lake development seem like a resort. Although they call it home, residents say they often feel like they're on vacation. Homeowners here can enjoy everything from biking, boating or swimming to nature walks, all in their own back yard.

You might think an exclusive development like this would require a long commute to work and other daily activities. Think again. Hidden Lake is located minutes from two major expressways in Green Oak Township and Brighton School District. It's 20 minutes from Ann Arbor, 10 minutes from South Lyon and Brighton and five minutes away from the new shopping development at Lee Road and US-23.

"There's really no place like it. It's truly resort style living. Every day you can play, relax and unwind," said Diane Paczas, marketing director and office administrator for Beck Development Co. and Green Oak Properties.

Mystery and mystique

From the beginning, developers set out to develop a one-of-a-kind community and lifestyle. A jewel in the heart of Livingston County, once prospective buyers visit here, the community sells itself, Paczas said.

"Hidden Lake is so aptly

HIDDEN LAKE

More information
The Information and Marketing Center is open 11 a.m.-6 p.m. daily. Or call (248) 446-3541.

Location
Hidden Lake is located one mile east of US-23. Take Silver Lake Road (exit 55) off US-23, just three miles south of I-96.

Online
Visit www.hiddenlakeonline.com.



Hidden Lake offers plenty of unique features and services for community residents.

named, because we are tucked back from the main roads," she said.

Not visible to the public is the dramatic entryway, breathtaking lake view, waterfalls and luxurious mature landscaping, natural woodlands and wetlands. It's a pleasant surprise to first-time visitors.

Hidden Lake is a 110-acre all sport spring fed lake, (jet skis prohibited). It features a private community marina with boat launch, fishing pier, as well as a sandy beach and designated swimming area. The community commons area features a cabana building equipped with a concession stand that sells ice cream, slushes and popcorn during the summer months. It also features an amphitheater where many events are scheduled. Homes not located on the lake may purchase or lease boat slips for lake access.

Four different floor plans are available, with base prices starting at \$395,000 for these attached condominiums. Single-family and estate homes come in various sizes and prices ranging from the low \$500,000s to \$1 million-plus.

From condos to estates

In addition to single-family homes, there are many premium attached condominiums available, with full privileges of the community.

"They have some of the prettier

views in the community, because they're not only by the lake, they also have a view of the waterfalls," Paczas said. Attached condominium units range from 2,200-2,700 square feet, each with a walk-out lower level which allows expandable living space.

"They've very livable, well-designed floor plans."

Events are scheduled throughout the year by the community association at the gazebo. That includes weekend concerts at the amphitheater for residents (only), school's out picnic, special activities for teens and "tweens," annual

Octoberfest, holiday tree lighting and more. Although there are many social opportunities, those who enjoy solitude will find it there, too, she assured.

A home and a lifestyle

Another feature that adds to the mystique of Hidden Lake is the sense of community that's fostered among residents. Paczas said camaraderie develops among them.

"There's such a large social fabric people have picked up on it and created their own subgroups for things like card parties, golf or ladies night out," she said.

Events are scheduled throughout the year by the community association at the gazebo. That includes weekend concerts at the amphitheater for residents (only), school's out picnic, special activities for teens and "tweens," annual

Octoberfest, holiday tree lighting and more. Although there are many social opportunities, those who enjoy solitude will find it there, too, she assured.

In addition to the numerous recreation opportunities already found at Hidden Lake, even more activities and points of interest are close at hand including Moose Ridge Golf Course, Kensington Metropark, Mt. Brighton and Island Lake State Park.

"The overall theme for Hidden Lake is set to be English Manor or French Country Cottage," said Paczas. To maintain the integrity of this premium development, there are architectural controls and landscaping standards. Several builders have been pre-approved by the development for single family homes.

A HOME For All Seasons

HIDDEN LAKE

A BECK DEVELOPMENT COMMUNITY

Luxury Resort Style Living!

Minutes away from:
Ann Arbor / Brighton / Howell / Plymouth / Novi
Hidden Lake is located one mile east of US-23. Take Silver Lake Road (Exit 55) off US-23, just three miles south of I-96.
Call 248-446-3541 for more information or visit us on the web at www.hiddenlakeonline.com
Marketing Information Center Open 7 days a week 11am to 6pm

Single Family Estate Homes

Attached condominium homes

New decorated models.

Priced from the upper \$300's to \$1 million plus

GREEN SHEET

apartments.com
Get what you want.

Homescape
For the Homeowner

careerbuilder.com

cars.com
Find the right car for you



SERVICE GUIDE 0010-2290
REAL ESTATE 3000-4980
EMPLOYMENT 5000-5890
ANNOUNCEMENT 6000-6780
MERCHANDISE 7000-7780
ANIMAL/PETS 7800-7980
AUTOMOTIVE 8000-8990

To Place Your Classified Ad:
Toll Free

1-888-999-1288

hometownlife.com

Your #1 Source for Classifieds in Your Hometown!

ASK ABOUT OUR VALUE PACKAGE!

Delivered in our fast-growing affluent communities in print and online!

DEADLINE: 4:00PM TUESDAY

GreenSheet Classifieds
P.O. Box 2309
Howell, MI 48847

WE ACCEPT



For more Real Estate ads, look to our new
Hometownlife.com Real Estate section inside today's paper!

COLDWELL BANKER

CALLAN, REALTORS®
(248) 685-1588

Highland Lakelake- 202' of sandy frontage on all-sports Duck Lake! 4 Bed, 2.5 Ba w/amazing wet bar in walkout, 3+ car Garage w/takeside door, plenty of updates & so much more! \$599,000 (C-4028)

Millford Village- 3 Bed, 2 Bath w/new part, carpet, hardwood & Bath. Xtra large 2 car Garage, modern Kitchen w/deep pantry, lovely 3 season porch, central air, fenced yard. \$173,000 (P-758)

Millford- 3+ Acres- 3 Bed, 3 Bath remodeled in 1997 w/3 fireplaces, great Master Ste, Garage + pole barn - bring your horses! More acreage available. \$399,995 (G-135)

South Lyon Ranch- 3 Bed, 1 Bath w/extra large eat-in kitchen, updated Bath, finished lower level, large deck, 2 car Garage, fenced yard, lots of storage & appliances included. \$185,000 (C-345)

Millford Lakelake- 3 Bed, 1.5 Bath contemporary on Moore Lake! Remodeled in 2005! New hardwood, carpet, Kitchen, Baths, windows, AC, well plumbing, electric & more! \$245,000 (P-937)

COLDWELL BANKER

CALLAN, REALTORS®
(248) 685-1588

3000-4980 REAL ESTATE

NOVI OPEN HOUSE
Sunday 11-5
Detached Condo, 2 car garage, golf community w/pool, over 2000 sq ft, 1st floor master bdrm & bath, large lower walkout w/deck. \$299,000
41534 Cypress Way
248-613-2070

SOUTH LYON 3 br., 1.5 bath colonial, 2 car attached garage. \$233,900 Open house Sat. 11-2pm 824 Downy Nest, or call for appt. 248-921-2067

BRIGHTON 1400 sq ft. Ranch w/3 br., 2 bath, 2 car garage. \$165,000 517-548-7518

BRIGHTON, Beautiful, contemporary, 2,800sq ft., wooded lot. Many custom extras \$314,900 (810)227-9335

FARM HOUSE
130 years old, well maintained, electrical & plumbing updated, 4 bdrm, 3 bath, parlor, living room, large kitchen, computer room, unique 2 separate upstairs, 2 out buildings 30x60 each, 2 car garage \$205,000 810-629-3016

NEW CONSTRUCTION 4Br 5 baths with loft & walkout 2.5 acres with pond. Inscop Hills Sub \$320,000 810-227-7784

COLDWELL BANKER SCHWEITZER NORTHVILLE

We are proud to welcome our newest associate to the team:
"Top Producer" CINDY MANCINA
With 10 years experience and over \$27 Million Sold
(248) 347-3050
cmancina@cbschweitzer.com

COLDWELL BANKER **Schweitzer Real Estate**

Open Houses 3030

Open Houses 3030

Hartland 3200
FABULOUS FAMILY HOME
in an excellent location 2400sq ft., 4 br., 2.5 baths, finished bsmt., lots of upgrades \$283,500 586-872-5212

IN VILLAGE 1800 sq ft. 4 br., 1 bath, New roof, fenced-in yard new windows, new furnace c.a., \$150,000 810-632-6448

Howell 3230
2 BR. 1 BATH C.A., all appliances \$5,000/best. Call 517-404-0241

INVESTORS SPECIAL 2400 sq ft. 3-4Br, 2 bath Priced \$50,000 under value. A MUST SELL \$189,000 517-552-9282

Wilford 3260
OVER 2500 SQ. FT.
Gorgeous ranch home that fronts on Kensington Metro Park. Fenced for horses One-of-a-kind 301 Martindale Rd. Asking \$585,900
ALTERNATIVE REALTY
248-348-5977 313-820-2299

Northville 3280
CHARMING 3 br., 2 bath ranch, full finished basement w/kitchen, all newer appliances stay. Within walking distance to downtown immediate occupancy! Great deal @ \$225,000! Call Lynda @ Lakes Realty 810-231-1600

Homes 3000

Northville 3280
FAIRBROOK CONDO
1st floor, 2 1/2 updated kitchen & bath, priced below market. \$89,500
Call Ruth 810-225-8117
Century 21 Brighton Towne
1024 E. Grand River Ave.

Pinckney 3340
COTTAGE - Access to Buck Lake and Huron River 2 BR, 1 bath, 824 sq ft. on double lot, newly remodeled \$119,900
MLS# 26079753
517-930-1214 agent/owner

South Lyon 3400
CAPE COD
4 Bdrm 2 full bath, 125 acres. \$277,000 Open house Sundays 1-4pm Details at www.tomacsoftware.com/house4sale (248)437-8458 9am 8pm Please

CAPE COD
4 br., 2.5 bath, 1.06 acres. Walk-out bsmt, 2896sq ft, attached 3 1/2 car garage. Bonus room above garage. \$470,000 Call for appt 249-446-6139

Homes 3000

Stockbridge-Unadilla-Gregory 3405
2 BR. HOME on 3 acres \$120,000 517-404-7706 cr 517-223-0711

Webberville 3438
1-STORY HOME 3 br., easy accessible bathroom. Utility room, front porch, back deck, 2 car garage, on 1.5 lots. Easy access to 196. \$136,000 517-521-3135 517-490-4544

Wixom-Commerce 3440
DREAM HOUSE Huge 2004 Ranch 4 Br Marble & Granite 1 Acre \$529K. Keller Williams 248-767-5100 www.wixomranch.com

Lakefront/Waterfront Homes 3580
BRIGHTON, 4 BR. All sports lake Lease/option \$374,000 810-227-6272

Wixom-Commerce 3440
HIGGINS LAKE 4 bdrm., 2 full/2-1/2 bath enclosed porch, extensive deck, 90 ft. waterfront, \$799,000 248-703-6509

HIGHLAND -All Sports 1 acre, walkout, 3br 2.5 bath, garage, \$265,000 Land contract negotiable 810-225-7657

LINDEN Lobdell Lk. New built Completion in August. Hurry & you can still pick your decor Call Kirk at Burnett Realty 810-691-7536

Out of State Homes/Property 3600
FALL CREEK FALLS AREA, TN
1.5 acre parcels from the \$40's Amazing rolling vista views Planned clubhouse nature trails 1 hour to Chattanooga Call owner 866-875-9206

MORTGAGE MONITOR

		30 Yr	Pts.	15 Yr	Pts.	ARM1	Pts	Other
1st Choice Mortgage Lending	(734) 459-0782	6.5	0	6.25	0	5	0	J/A
A Best Financial Corp	(800) 839-8918	6.125	1.625	5.625	2.125	5.625	1.5	J/A
A Perfect Mortgage Co.	(248) 203-7726	6.5	0	6.25	0	5.75	0	J/A
AAXA Discount Mortgage	(877) 728-3569	6.5	0.25	6.125	0.25	5	0	J/A
AFI Financial	(877) 234-0600	6.25	1.25	6	0.75	NR	NR	J/A
American Home Mortgage	(877) 478-7289	6.375	2	6	2	4.375	2	J/A/V/F
Amenplus Mortgage Corp.	(248) 740-2323	6.5	0.25	6.25	0.25	5.875	0	J/A
Brighton Commerce Bank	(810) 220-8646	6.875	0	6.5	0	6.5	0	J/A
Brinks Goldstar Mortgage	(800) 785-4755	6.625	0	6.25	0.25	4.5	0	J/A/V/F
Capital Mortgage Funding	(248) 569-7283	6.625	1.5	6.375	1.5	NR	NR	J/A/F
Centerbrook Mortgage	(248) 851-4150	NR	NR	NR	NR	NR	NR	J/A
Charter One Bank	(800) 342-5336	7	0	6.625	0	NR	NR	J/A/V/F
Client Services by Golden Rule	(800) 569-5805	6.125	1.625	5.75	1.625	2.5	1	J/A/V/F
Co-op Services Credit Union	(734) 466-6113	7	0	6.75	0	5.5	0	J
Community Bank of Dearborn	(734) 981-0022	6.75	0	6.375	0	6	0	J/A/V/F
Credit Union One	(800) 544-5567	7.125	0	6.625	0	NR	NR	J/A
Dearborn Federal Savings Bank	(313) 565-3100	6.625	0	6.25	0	5.75	0	A
DFCU Financial	(800) 739-2770	6.5	2	6.125	2	NR	NR	J/A
Downriver Community FCU	(313) 386-2200	6.75	0	6.35	0	6.25	0	J/A
Earth Mortgage	(877) 327-8450	6.625	0	6.25	0	5.375	0	J/A/V/F
Fifth Third Bank	(800) 792-8830	6.75	0.375	6.375	0.375	5.875	0.125	J/V/F
First Alliance Mortgage Co	(800) 292-7357	6.75	0	6.5	0	NR	NR	J/A/V/F
First International Mortgage	(248) 540-1065	6.625	0	6.25	0	NR	NR	J/A
GMAC Mortgage Corp	(800) 888-4622	6.25	3	5.875	3	5.375	1	J/A/V/F
Golden Rule Mortgage	(800) 991-0922	6	2.125	5.625	2.125	2.25	2	J/A/V/F
Goldstar Mortgage	(800) 784-1072	6.5	0	6.25	0	3.125	0	J/A/V/F
Group One Mortgage	(734) 953-4000	6.75	0	6.375	0	6	0	J/A/V/F
LaSalle Bank Midwest	(800) 466-3800	6.5	2	6.25	2	4.875	2	J/A/V/F
Mainstreet Mortgage	(800) 900-1313	6.75	0	6.5	0	NR	NR	J/A/V/F
Manufacturers	(586) 777-1000	6.125	2	5.75	2	NR	NR	J/A
Michigan Schools & Gov. CU	(586) 263-8900	6.75	0	6.375	0	5.375	0	J/A
Mortgages by Golden Rule	(800) 991-9922	6.25	1.125	5.875	1.125	2.5	1	J/A/V/F
National City Bank	(586) 825-0825	6.5	1.75	6.125	2	5.875	1.25	J/A
Northlawn Financial	(248) 988-8488	6.625	0	6.25	0	NR	NR	J/A/V/F
Pathway Financial LLC	(800) 726-2274	6.5	0	6.25	0	4.25	0	J/A/F
Peoples Mortgage	(800) 730-5087	6.375	0.5	6	0.75	NR	NR	J/A
Premiere Mortgage Funding	(800) 684-7880	6.625	0	6.25	0	4.875	0	J/A
Shore Mortgage	(800) 678-6663	6.125	3	5.75	3	3.75	3	J/A/V/F
United Mortgage Group	(586) 286-9500	6.5	0	6.25	0	7	0.25	J/A
York Financial Inc.	(888) 839-9675	6.625	0	6.25	0	6	0	J/A

Above information available as of 6/27/06 and subject to change at any time. Rates are based on \$200,000 loan with 20% down. Jumbo rates, specific payment calculations & most current rates available Fridays after 2:00 P.M. at www.rmcreport.com Key to "Other" Column - J = Jumbo, A = Arms, V = VA, F = FHA, R = Reverse Mtg & NR = Not Reported All Lenders are Equal Opportunity Lenders

© Copyright 2006 Residential Mortgage Consultants, Inc. All Rights Reserved

Gold Star Mortgage Banking Group

Don't get caught between a ROCK and a Hard place,
1-800-785-4755
go for GOLD

RECORDED & INDEXED

Highland Top
1796 Valley Dr. \$185,000
1809 Gleneagles \$535,000

Lyon Top.
25686 Coach Ln. \$23,975
58770 Carriage Ln. \$70,000
26500 Daria Circle E. \$100,000
61340 Fairland Dr. \$210,000

Millford Top.
4194 Windrup Farms \$147,000
2100 Pinewood Ct. \$250,000

Millford Village
324 Crystal St. \$150,000
1055 Woodvale Ct. \$361,000

Novi City
42121 Pellston St. \$139,900
22322 Mystic Street \$300,000
22742 Autumn Park Blvd. \$670,000
50520 Drakes Bay \$1,491,151
41584 Hamlet Lane \$203,350
41574 Hamlet Lane \$210,891
25552 Portico Lane \$230,000
21705 Clover Lane \$259,000
25089 Newberry Dr. \$354,000
44720 Gwinnett Loop \$186,190
48000 Twelve Oaks Crescent \$187,000
146 Haven St. N. \$195,000
31110 Centennial Dr. \$202,000
43000 Twelve Oaks Crescent \$210,000
44860 Stockton \$262,500
40827 Lenox Park Dr. \$278,555
40802 Lenox Park Dr. \$279,910
1640 Lake Dr. W. \$291,000
1405 Lake Dr. E. \$297,000
40807 Lenox Park Dr. \$307,160
1405 Lake Dr. E. \$317,500
40028 Kingsley Lane \$114,000
45691 Marlborough \$500,000

South Lyon City
1213 Gentry Dr. \$00,000
225 Brookwood Dr. 4 \$106,000
140 Aspen \$184,900
22146 Brookfield \$285,000

CALL DAVE MANN
248-684-0021
OR
800-652-MANN

RE/MAX Classic
DaveMann.com
248-684-6655

Information provided by First American Real Estate Solutions

Condos 3720
NORTHVILLE Beautiful 2 BR, 1.5 bath, new appliances & carpet. Fenced yard. Lease avail. \$129,900. 248-349-4139

Manufactured Homes 3740
Little Valley
3 Bed, Like New HOMES AVAILABLE
\$9,990
\$12,990
\$14,990
\$19,990

Lakefront Property 3170
SOUTHERN MI LAKEFRONT
Lot 1 - Woods, water & seclusion along w/ 100' frontage 1/2 hour from Lake Mi. \$59,900

Lots & Acreage/Vacant 3820
JACKSON COUNTY, Concord 58 acres, prime deer & turkey, buildable. Close to home \$195,000. (248) 705-5833

Money to Loan/Borrow 3840
DR. DANIELS AND SON REAL ESTATE LOANS AND BUY'S LAND CONTRACTS

Apartments/Unfurnished 4000
BRIGHTON Clean 2 br. in town, on-site laundry. \$525/mo + deposit. 810-599-7176

Apartments/Unfurnished 4000
HOWELL QUAIL Creek Apts. 1-2 br., \$545 - \$655/mo incl. covered carport

Apartments/Unfurnished 4000
SOUTH LYON'S Premier Luxury Apartment Community
\$99 Special!

Apartments/Unfurnished 4000
MILFORD 2 br., special. Close to downtown, heat & water incl. First months rent free with good credit. (248) 685-1524

Manufactured Homes 3740
Novi View the pond from your covered deck. 3B/2B Double Wide. New carpet & appliances. \$1,295 Moves You In! 1-888-251-4353

Little Valley
Must See. New 3 Bd. 2 Ba. Home. \$19,900. Childs Lake Estates 248-685-7770

Northern Property 3790
KALKASKA 10 ACRES
Wooded, maintained country road w/electric. Close to State Forest! \$24,900. \$15,000 down. \$325/mo. More acreage avail. See photos at greatlakesland.com or call 231-331-4227

Real Estate Wanted 3870
ALL CASH FOR HOMES. Fast closings. Any Style Any Condition 313-662-6111, 247

Cemetery Lots 3930
OAKLAND HILLS Memorial 4 plots in one lot, Masonic Gardens. \$1200 each. Call (815) 645-8423

Apartment/Unfurnished 4000
HOWELL - Byron Terrace Walk to shopping & festive events. 2 br. apts. From \$539/mo. \$99 security deposit. 517-546-3396

Apartment/Unfurnished 4000
MILFORD SUMMER SPECIAL! \$50 off next 3 months rent 1 & 2 br apts. starting at \$535. Fully carpeted, central air, heat incl. No pets. (248) 684-0841

Apartment/Unfurnished 4000
MILFORD Main St. apt. in quiet Downtown, 1 br, attached indoor parking. Call 248-685-0789 248-685-3532

Apartment/Unfurnished 4000
MILFORD 2 br. apts. starting at \$535. Fully carpeted, central air, heat incl. No pets. (248) 684-0841

775 Move You In! 2 bedroom home with an enclosed porch and expando. Many updates. Novi 888-251-4353

Little Valley
Must See. New 3 Bd. 2 Ba. Home. \$19,900. Childs Lake Estates 248-685-7770

Lakefront Property 3170
SOUTHERN MI LAKEFRONT
Lot 1 - Woods, water & seclusion along w/ 100' frontage 1/2 hour from Lake Mi. \$59,900

Real Estate Wanted 3870
ALL CASH FOR HOMES. Fast closings. Any Style Any Condition 313-662-6111, 247

Cemetery Lots 3930
OAKLAND HILLS Memorial 4 plots in one lot, Masonic Gardens. \$1200 each. Call (815) 645-8423

Apartment/Unfurnished 4000
HOWELL - Byron Terrace Walk to shopping & festive events. 2 br. apts. From \$539/mo. \$99 security deposit. 517-546-3396

Apartment/Unfurnished 4000
MILFORD SUMMER SPECIAL! \$50 off next 3 months rent 1 & 2 br apts. starting at \$535. Fully carpeted, central air, heat incl. No pets. (248) 684-0841

Apartment/Unfurnished 4000
MILFORD Main St. apt. in quiet Downtown, 1 br, attached indoor parking. Call 248-685-0789 248-685-3532

Apartment/Unfurnished 4000
MILFORD 2 br. apts. starting at \$535. Fully carpeted, central air, heat incl. No pets. (248) 684-0841

775 Move You In! 2 bedroom home with an enclosed porch and expando. Many updates. Novi 888-251-4353

Little Valley
Must See. New 3 Bd. 2 Ba. Home. \$19,900. Childs Lake Estates 248-685-7770

Lakefront Property 3170
SOUTHERN MI LAKEFRONT
Lot 1 - Woods, water & seclusion along w/ 100' frontage 1/2 hour from Lake Mi. \$59,900

Real Estate Wanted 3870
ALL CASH FOR HOMES. Fast closings. Any Style Any Condition 313-662-6111, 247

Cemetery Lots 3930
OAKLAND HILLS Memorial 4 plots in one lot, Masonic Gardens. \$1200 each. Call (815) 645-8423

Apartment/Unfurnished 4000
HOWELL - Byron Terrace Walk to shopping & festive events. 2 br. apts. From \$539/mo. \$99 security deposit. 517-546-3396

Apartment/Unfurnished 4000
MILFORD SUMMER SPECIAL! \$50 off next 3 months rent 1 & 2 br apts. starting at \$535. Fully carpeted, central air, heat incl. No pets. (248) 684-0841

Apartment/Unfurnished 4000
MILFORD Main St. apt. in quiet Downtown, 1 br, attached indoor parking. Call 248-685-0789 248-685-3532

Apartment/Unfurnished 4000
MILFORD 2 br. apts. starting at \$535. Fully carpeted, central air, heat incl. No pets. (248) 684-0841

775 Move You In! 2 bedroom home with an enclosed porch and expando. Many updates. Novi 888-251-4353

Little Valley
Must See. New 3 Bd. 2 Ba. Home. \$19,900. Childs Lake Estates 248-685-7770

Lakefront Property 3170
SOUTHERN MI LAKEFRONT
Lot 1 - Woods, water & seclusion along w/ 100' frontage 1/2 hour from Lake Mi. \$59,900

Real Estate Wanted 3870
ALL CASH FOR HOMES. Fast closings. Any Style Any Condition 313-662-6111, 247

Cemetery Lots 3930
OAKLAND HILLS Memorial 4 plots in one lot, Masonic Gardens. \$1200 each. Call (815) 645-8423

Apartment/Unfurnished 4000
HOWELL - Byron Terrace Walk to shopping & festive events. 2 br. apts. From \$539/mo. \$99 security deposit. 517-546-3396

Apartment/Unfurnished 4000
MILFORD SUMMER SPECIAL! \$50 off next 3 months rent 1 & 2 br apts. starting at \$535. Fully carpeted, central air, heat incl. No pets. (248) 684-0841

Apartment/Unfurnished 4000
MILFORD Main St. apt. in quiet Downtown, 1 br, attached indoor parking. Call 248-685-0789 248-685-3532

Apartment/Unfurnished 4000
MILFORD 2 br. apts. starting at \$535. Fully carpeted, central air, heat incl. No pets. (248) 684-0841

\$8,500 Immaculate Home in Hometown Novi. Backs to pond. This one is truly a diamond in the rough. Won't last long. 251-4353

Little Valley
Must See. New 3 Bd. 2 Ba. Home. \$19,900. Childs Lake Estates 248-685-7770

Lakefront Property 3170
SOUTHERN MI LAKEFRONT
Lot 1 - Woods, water & seclusion along w/ 100' frontage 1/2 hour from Lake Mi. \$59,900

Real Estate Wanted 3870
ALL CASH FOR HOMES. Fast closings. Any Style Any Condition 313-662-6111, 247

Cemetery Lots 3930
OAKLAND HILLS Memorial 4 plots in one lot, Masonic Gardens. \$1200 each. Call (815) 645-8423

Apartment/Unfurnished 4000
HOWELL - Byron Terrace Walk to shopping & festive events. 2 br. apts. From \$539/mo. \$99 security deposit. 517-546-3396

Apartment/Unfurnished 4000
MILFORD SUMMER SPECIAL! \$50 off next 3 months rent 1 & 2 br apts. starting at \$535. Fully carpeted, central air, heat incl. No pets. (248) 684-0841

Apartment/Unfurnished 4000
MILFORD Main St. apt. in quiet Downtown, 1 br, attached indoor parking. Call 248-685-0789 248-685-3532

Apartment/Unfurnished 4000
MILFORD 2 br. apts. starting at \$535. Fully carpeted, central air, heat incl. No pets. (248) 684-0841

775 Move You In! 2 bedroom home with an enclosed porch and expando. Many updates. Novi 888-251-4353

Little Valley
Must See. New 3 Bd. 2 Ba. Home. \$19,900. Childs Lake Estates 248-685-7770

Lakefront Property 3170
SOUTHERN MI LAKEFRONT
Lot 1 - Woods, water & seclusion along w/ 100' frontage 1/2 hour from Lake Mi. \$59,900

Real Estate Wanted 3870
ALL CASH FOR HOMES. Fast closings. Any Style Any Condition 313-662-6111, 247

Cemetery Lots 3930
OAKLAND HILLS Memorial 4 plots in one lot, Masonic Gardens. \$1200 each. Call (815) 645-8423

Apartment/Unfurnished 4000
HOWELL - Byron Terrace Walk to shopping & festive events. 2 br. apts. From \$539/mo. \$99 security deposit. 517-546-3396

Apartment/Unfurnished 4000
MILFORD SUMMER SPECIAL! \$50 off next 3 months rent 1 & 2 br apts. starting at \$535. Fully carpeted, central air, heat incl. No pets. (248) 684-0841

Apartment/Unfurnished 4000
MILFORD Main St. apt. in quiet Downtown, 1 br, attached indoor parking. Call 248-685-0789 248-685-3532

Apartment/Unfurnished 4000
MILFORD 2 br. apts. starting at \$535. Fully carpeted, central air, heat incl. No pets. (248) 684-0841

Service Directory

The #1 Source for the help you need. Call 888-999-1288

0010-2980 SERVICE GUIDE
Asphalt/Blacktopping 0110

0410 Carpentry
A.B.N. CONSTRUCTION Homes, garages, additions & decks. We build it like it's our own. Rick 810-523-2923

0550 Concrete
diopattos.com - All types, drives, replacements, Lic. 800-758-4774 / 517-223-6797

0920 Garage Door Installation & Repair
Beckway Door COMMERCIAL - RESIDENTIAL

1030 Hauling/Clean Up
TAKE IT AWAY HAULING Construction debris, home discards & cleanout. appliances, etc. 248-348-3822

1210 Landscaping
LANDSCAPING & CLEAN-UP Power Washing Light hailing, hailing, man, no job too small! Jason, 517-425-9595

1420 Painting/Decorating Paperhangers
PAUL'S Professional Painting Lic. Val'd #1 House Painter People's Choice Awards 2003, 2004, 2005 & 2006

1640 Roofing
Frank the Roofer Over 30 Years Experience We take every roof personally

1950 Top Soil/Gravel
NORTHVILLE SUPPLY YARD 7868 Chubb Road Northville

0110 Asphalt/Blacktopping
A&N asphalt Inc. paving and maintenance

0410 Carpentry
CARPENTER REPAIRS Decks powerwashing, roofs, painting Make, (810) 599-6045

0550 Concrete
FERRAZZA CEMENT CONSTRUCTION Quality & Affordability since 1972. All types of concrete work. Free Est. 248-561-9363

0920 Garage Door Installation & Repair
Beckway Door COMMERCIAL - RESIDENTIAL

1030 Hauling/Clean Up
TOPSOIL, SAND, GRAVEL, Demolition & Driveway, etc. Backhoe, Skidsteer, Dozer Dump truck w/operator. 810-231-2591, 810-772-6518

1210 Landscaping
Two Shovels & A Wheel Barrow Digging & Small Landscaping jobs (248) 974-4840

1420 Painting/Decorating Paperhangers
PAUL'S Professional Painting Lic. Val'd #1 House Painter People's Choice Awards 2003, 2004, 2005 & 2006

1640 Roofing
G.J. Kelly Const. Inc. Roofing Siding, Gutters, Additions, Decks Lic/Ins 248-685-0366

1950 Top Soil/Gravel
NORTHVILLE SUPPLY YARD 7868 Chubb Road Northville

0290 Brick, Block & Cement
ALL CEMENT & MASONRY Everything - Repairs/ New 35 Yrs., Lic. & Ins. Free Est. (248) 348-0066

0410 Carpentry
CARPENTRY BY DAVID G. SWEENEY Small, medium, rough & finish. Decks, bsmt., kitchens, etc. Lic. & Ins. 248-698-8670

0550 Concrete
POURED BASEMENT WALLS Basement floors, garage floors, driveways, pole barns, etc. Free Estimates 517-223-3880

0920 Garage Door Installation & Repair
Beckway Door COMMERCIAL - RESIDENTIAL

1030 Hauling/Clean Up
A & M ENGINEERING A/C & Furnace Installation & Repairs. Res/Com. Lic. & Ins. Free Est. MCOV. Financing Available! Call 734-657-3080

1210 Landscaping
ALL LAWN MOWING Residential & Commercial Grandif Landscape Service 248-504-7843/734-483-7607

1420 Painting/Decorating Paperhangers
PAUL'S Professional Painting Lic. Val'd #1 House Painter People's Choice Awards 2003, 2004, 2005 & 2006

1640 Roofing
LEAK SPECIALIST Flashings valleys 30 yrs exp Tri County Roofing & Siding Member BBB Lic/Ins (810) 220-2363

1950 Top Soil/Gravel
NORTHVILLE SUPPLY YARD 7868 Chubb Road Northville

0310 Building Remodeling
FRAMING CREW - Exc. work Homes, siding add's, barns, decks, roofs Lic/Ins Dealer Construction, 810-231-3174

0410 Carpentry
THOMPSON HOME CONSTRUCTION LLC Homes, additions garages rough framing, decks 29 yrs exp Lic/Ins 248-437-8265

0550 Concrete
AFFORDABLE DECKS PLUS restoration & power washing Stain, seal or paint. 16 yrs exp Free est/ref guaranteed work. Scott, 517-898-6896

0920 Garage Door Installation & Repair
Beckway Door COMMERCIAL - RESIDENTIAL

1030 Hauling/Clean Up
AIR CONDITIONING & Furnace installation & repair Res. & com 18 yrs exp Fully Lic. & Ins. Free est 517-223-3223

1210 Landscaping
LAWY LIBERTY ENTERPRISES Landscaping & Maintenance, Boulder, Walnut, Brick Pavers, Retaining Walls, Shrubs, Trimming, Mulch, Plantings, Beaches, Topsoil, Sod Prep & Sodding Front End Loading & Land Clearing, Lawn Mowing 248-634-7041

1420 Painting/Decorating Paperhangers
PAUL'S Professional Painting Lic. Val'd #1 House Painter People's Choice Awards 2003, 2004, 2005 & 2006

1640 Roofing
TITAN ROOFING/SIDING. Res specialist Lic/Ins No sub-contracting (248) 974-7028

1950 Top Soil/Gravel
NORTHVILLE SUPPLY YARD 7868 Chubb Road Northville

0310 Building Remodeling
FRAMING CREW - Exc. work Homes, siding add's, barns, decks, roofs Lic/Ins Dealer Construction, 810-231-3174

0410 Carpentry
CARPET INSTALLATION Free estimates, all areas 248-889-1778 248-770-0237

0550 Concrete
BIOSAFE DECK CO. Powerwash, Clean & Seal \$325-up James 734-754-1440

0920 Garage Door Installation & Repair
Beckway Door COMMERCIAL - RESIDENTIAL

1030 Hauling/Clean Up
GUTTER HELMET Free Gutters and Downspouts 20% off Gutter Helmet System w/purchase cond apply 800-545-1779 www.atlasgutterhelmet.com

1210 Landscaping
LAWY LIBERTY ENTERPRISES Landscaping & Maintenance, Boulder, Walnut, Brick Pavers, Retaining Walls, Shrubs, Trimming, Mulch, Plantings, Beaches, Topsoil, Sod Prep & Sodding Front End Loading & Land Clearing, Lawn Mowing 248-634-7041

1420 Painting/Decorating Paperhangers
PAUL'S Professional Painting Lic. Val'd #1 House Painter People's Choice Awards 2003, 2004, 2005 & 2006

1640 Roofing
LEAK SPECIALIST Flashings valleys 30 yrs exp Tri County Roofing & Siding Member BBB Lic/Ins (810) 220-2363

1950 Top Soil/Gravel
NORTHVILLE SUPPLY YARD 7868 Chubb Road Northville

0310 Building Remodeling
FRAMING CREW - Exc. work Homes, siding add's, barns, decks, roofs Lic/Ins Dealer Construction, 810-231-3174

0410 Carpentry
CARPET VINYL, Hardwood, Laminate Sales, Installation & Repairs. 810-227-4897 OR 810-599-7074

0550 Concrete
All Drywall Repair, hanging remodeling, finishing 30 yrs exp Specialist (810) 908-4996

0920 Garage Door Installation & Repair
Beckway Door COMMERCIAL - RESIDENTIAL

1030 Hauling/Clean Up
ALL HOME SERVICES Handyman & remodeling services from changing a faucet to complete home remodeling Lic/Ins. Free est. 734-455-7770 Present this ad and receive 10% off any job

1210 Landscaping
LAWY LIBERTY ENTERPRISES Landscaping & Maintenance, Boulder, Walnut, Brick Pavers, Retaining Walls, Shrubs, Trimming, Mulch, Plantings, Beaches, Topsoil, Sod Prep & Sodding Front End Loading & Land Clearing, Lawn Mowing 248-634-7041

1420 Painting/Decorating Paperhangers
PAUL'S Professional Painting Lic. Val'd #1 House Painter People's Choice Awards 2003, 2004, 2005 & 2006

1640 Roofing
LEAK SPECIALIST Flashings valleys 30 yrs exp Tri County Roofing & Siding Member BBB Lic/Ins (810) 220-2363

1950 Top Soil/Gravel
NORTHVILLE SUPPLY YARD 7868 Chubb Road Northville

0310 Building Remodeling
FRAMING CREW - Exc. work Homes, siding add's, barns, decks, roofs Lic/Ins Dealer Construction, 810-231-3174

0410 Carpentry
CARPET VINYL Installation & Repairs. Hardwood & Laminate. (734) 268-6625

0550 Concrete
All Drywall Repair, hanging remodeling, finishing 30 yrs exp Specialist (810) 908-4996

0920 Garage Door Installation & Repair
Beckway Door COMMERCIAL - RESIDENTIAL

1030 Hauling/Clean Up
ALL HOME SERVICES Handyman & remodeling services from changing a faucet to complete home remodeling Lic/Ins. Free est. 734-455-7770 Present this ad and receive 10% off any job

1210 Landscaping
LAWY LIBERTY ENTERPRISES Landscaping & Maintenance, Boulder, Walnut, Brick Pavers, Retaining Walls, Shrubs, Trimming, Mulch, Plantings, Beaches, Topsoil, Sod Prep & Sodding Front End Loading & Land Clearing, Lawn Mowing 248-634-7041

1420 Painting/Decorating Paperhangers
PAUL'S Professional Painting Lic. Val'd #1 House Painter People's Choice Awards 2003, 2004, 2005 & 2006

1640 Roofing
LEAK SPECIALIST Flashings valleys 30 yrs exp Tri County Roofing & Siding Member BBB Lic/Ins (810) 220-2363

1950 Top Soil/Gravel
NORTHVILLE SUPPLY YARD 7868 Chubb Road Northville

0310 Building Remodeling
FRAMING CREW - Exc. work Homes, siding add's, barns, decks, roofs Lic/Ins Dealer Construction, 810-231-3174

0410 Carpentry
CARPET VINYL Installation & Repairs. Hardwood & Laminate. (734) 268-6625

0550 Concrete
All Drywall Repair, hanging remodeling, finishing 30 yrs exp Specialist (810) 908-4996

0920 Garage Door Installation & Repair
Beckway Door COMMERCIAL - RESIDENTIAL

1030 Hauling/Clean Up
ALL HOME SERVICES Handyman & remodeling services from changing a faucet to complete home remodeling Lic/Ins. Free est. 734-455-7770 Present this ad and receive 10% off any job

1210 Landscaping
LAWY LIBERTY ENTERPRISES Landscaping & Maintenance, Boulder, Walnut, Brick Pavers, Retaining Walls, Shrubs, Trimming, Mulch, Plantings, Beaches, Topsoil, Sod Prep & Sodding Front End Loading & Land Clearing, Lawn Mowing 248-634-7041

1420 Painting/Decorating Paperhangers
PAUL'S Professional Painting Lic. Val'd #1 House Painter People's Choice Awards 2003, 2004, 2005 & 2006

1640 Roofing
LEAK SPECIALIST Flashings valleys 30 yrs exp Tri County Roofing & Siding Member BBB Lic/Ins (810) 220-2363

1950 Top Soil/Gravel
NORTHVILLE SUPPLY YARD 7868 Chubb Road Northville

0310 Building Remodeling
FRAMING CREW - Exc. work Homes, siding add's, barns, decks, roofs Lic/Ins Dealer Construction, 810-231-3174

0410 Carpentry
CARPET VINYL Installation & Repairs. Hardwood & Laminate. (734) 268-6625

0550 Concrete
All Drywall Repair, hanging remodeling, finishing 30 yrs exp Specialist (810) 908-4996

0920 Garage Door Installation & Repair
Beckway Door COMMERCIAL - RESIDENTIAL

1030 Hauling/Clean Up
ALL HOME SERVICES Handyman & remodeling services from changing a faucet to complete home remodeling Lic/Ins. Free est. 734-455-7770 Present this ad and receive 10% off any job

1210 Landscaping
LAWY LIBERTY ENTERPRISES Landscaping & Maintenance, Boulder, Walnut, Brick Pavers, Retaining Walls, Shrubs, Trimming, Mulch, Plantings, Beaches, Topsoil, Sod Prep & Sodding Front End Loading & Land Clearing, Lawn Mowing 248-634-7041

1420 Painting/Decorating Paperhangers
PAUL'S Professional Painting Lic. Val'd #1 House Painter People's Choice Awards 2003, 2004, 2005 & 2006

1640 Roofing
LEAK SPECIALIST Flashings valleys 30 yrs exp Tri County Roofing & Siding Member BBB Lic/Ins (810) 220-2363

1950 Top Soil/Gravel
NORTHVILLE SUPPLY YARD 7868 Chubb Road Northville

Apartment/Unfurnished 4000

NORTHVILLE NORTHVILLE GREEN Now leasing 1 & 2 bdrm Condos in the historic town of Northville...

NORTHVILLE

Novi Road N of 8 Mile 1 MONTH FREE

\$199 MOVES YOU IN! Small, charming community nestled in a stream side setting...

NOVI 1 br. Country Setting Heat, water washer/dryer incl 6 month lease \$650/mo + sec dep 248-349-3732

NOVI

Meadowbrook N of 10 Mile ONE MONTH FREE

Hurry, includes our beautiful remodeled apartments with new kitchens and in unit washer/dryers!

Plymouth

1st MONTH FREE • 1 bdrm plus storage • Single Story w/ patio garden space & central air

SOUTH LYON 1 br. efficiency.

SOUTH LYON 2 BR. all appliance.

SOUTH LYON 2 BR. includes heat, near town.

South Lyon - MEADOWS OF SOUTH LYON

SOUTH LYON Summer special

Walled Lake JULY SPECIAL

WALLED LAKE'S EAGLE POND HEIGHTS

WALLED LAKE'S EAGLE POND TOWNHOUSES

WALLED LAKE'S EAGLE POND TOWNHOUSES

WEST BLOOMFIELD THORNBERY APTS.

WHITMORE LAKE, 2 br Onet neighborhood

WHITMORE LAKE, UNIQUE.

WHITMORE LAKE, UNIQUE.

WHITMORE LAKE, UNIQUE.

WHITMORE LAKE, UNIQUE.

WHITMORE LAKE, UNIQUE.

WHITMORE LAKE, UNIQUE.

WHITMORE LAKE, UNIQUE.

WHITMORE LAKE, UNIQUE.

WHITMORE LAKE, UNIQUE.

WHITMORE LAKE, UNIQUE.

WHITMORE LAKE, UNIQUE.

WHITMORE LAKE, UNIQUE.

WHITMORE LAKE, UNIQUE.

WHITMORE LAKE, UNIQUE.

WHITMORE LAKE, UNIQUE.

WHITMORE LAKE, UNIQUE.

WHITMORE LAKE, UNIQUE.

WHITMORE LAKE, UNIQUE.

WHITMORE LAKE, UNIQUE.

WHITMORE LAKE, UNIQUE.

Condos/Townhouses 4020

COMMERCER/WALLED LAKE 1.5 Mile & Beck. All appliances, 2 bdrm, 2 bath, garage, no stairs, pool & patio.

HIGHLAND- 2 BR. no pets. \$675 + utilities First/last month rent. (248) 887-7138

HOWELL Ground floor ranch, private setting, 2 br 2 bath, 2 car attached garage \$950/mo

HOWELL. Newer 2 br, 2 bath, \$895/mo or lease with option \$119,900 517-231-7082

HOWELL- SPACIOUS 2 br, 2 bath, 1 550 sq ft w/lot. 2 car, pool, near x-way \$1,200/mo

MILFORD downtown, 2br, 1.5 bath, incl appliances, 2 story \$775/mo

MILFORD, DOWNTOWN Quiet, cozy 2 br (formerly apt), unit closest to lake \$775/mo

NOVI/WXOM, 1600sq ft, 2 br, garage, Maple Grassing Pool, Jacuzzi, private entrance \$950/mo

SOUTH LYON Condo, 1 br, appliances, remodeled Avail now \$675/mo

SOUTH LYON, DOWNTOWN 2 br, 1.5 bath, bsmt, all appliances incl. washer/dryer 248-207-7129

Duplexes 4030

BRIGHTON 2 br, appliances, carpeting, basement, garage, patio, no pets. Exc cond \$775/mo

BRIGHTON, 2 br, ranch style, new carpet & paint, stove, fridge, laundry hook-ups, A/C NO PETS \$680 + deposit 734-878-8915

BRIGHTON, 2 br, unit, quiet area, good access to freeways \$675/mo, no pets 517-404-0161

BRIGHTON- Near Downtown, 319 N Third, 2 br, freshly painted, w/appliances, wash & dry c/a, \$685 810-227-2068

HAMBURG 2 br, c/a, garage, 1 acre wooded lot, close to x-way Call 734-878-6998

HARTLAND, 2 br ranch units, air, garage, no pets Start \$675/mo, 1/2 rent for 60 days w/13 mo lease 734-497-0960

MILFORD 1 br, all appliances, pets allowed \$575/mo Avail July 1, 2006 248-685-8103

SOUTH LYON Attractive, 2 BR. Heat & water incl. \$595 + sec Immediate occupancy (734) 453-1735

Homes for Rent 4050

BRIGHTON 1 acre all on brighton lake, 3 br, 1 bath \$1300/mo 810-923-6508

BRIGHTON-1600 sq ft. Nice 3 BR Ranch, \$1150/mo rent \$800 security (810) 333-3845

BRIGHTON, 2 br, ranch, \$800/mo First mo + security No pets (810)231-0376

BRIGHTON 2700 sq ft, 4 br, bsmt, garage/shed, pool, \$1300/mo 810-227-6354

BRIGHTON, 3 br, 3 bath, 2.5 garage, 1.600sq ft, full bsmt, Hartland schools, 15 acre w/pool, \$1,580 972-365-0468

BRIGHTON, 3 br, C.A., in family sub \$1,200/mo + utilities No pets 810-229-5223

BRIGHTON 3 br, Clark Lk., all appliances 2 car garage, no smoke \$1175 810-229-0396

BRIGHTON 3 br ranch w/family room, appliances incl \$1100/mo, 810-225-4540

BRIGHTON 4 br, 2.5 bath, ranch w/finished walkout bsmt, lg yard, 12 mo lease, \$1500/mo 404-435-4401

BRIGHTON 4 br, all sports Island Lake, \$1,375 + utilities Rent or buy 248-446-8205

BRIGHTON, COZY 2 br, views of 2 lakes, w/aceess, all appliances, \$895 810-227-6231

Brighton Fin. walkout, 3600 sq ft living space, \$1295 mo/Buy \$239,900 Lk 734-787-0899

BRIGHTON Lake view/acreage 2 br/office, air, garage, Pets OK, \$1200/mo 810-494-9071

BRIGHTON New Home Lake view, 3br. Avail Now \$975/mo + Security 517-404-4199

HAMBURG TWP 2300 sq ft new home 3 br Walkout bsmt. Ore Lake Access \$1490/mo (734) 383-7653

HAMBURG TWP, Executive home, 4 br, 3 baths, fireplace, 4 car garage RENT W/OPTION \$1695 short/long term lease 810-333-9140, 734-878-5055

HAMBURG TWP, Stunning new 3300sq ft Executive home 4 br, 3.5 baths, 3 car garage, gourmet granite kitchen 2 miles from 23 in country sub \$2,000/mo 20th Century, 810-231-3300

HARTLAND 3 Br, 3 bath ranch, Garage, large lot \$1,200/mo (248) 882-8880

HARTLAND LEASE PURCHASE No bank needed All credit, 4 BR, 3 Car, 5+ acres, \$2000/mo Call, 810-577-2239

HARTLAND SCHOOLS 3 BR Farm House Nice country living \$750/mo + security Credit check 517-546-3097

HIGHLAND 3 br, 1200 sq ft. Dishwasher, refrigerator & stove 3 miles N of M-59 on Kerry, off Milford Rd \$800/mo 248-685-2264

HOLLY 4 br downtown Remodeled w/ large country kitchen. Fenced yard Appliances \$1,150 avail now 248-698-3940/248-421-9777

HOWELL-2 BR, COUNTRY Setting 1st & last \$750/mo (734) 878-3862

HOWELL 3 br, 2 bath ranch, beautiful setting A/C \$1300/month 248-347-1166

HOWELL 3 br, ranch, c.a. wood floors, acre + secluded fenced yard, attached garage \$1,345/mo (810)227-6231

HOWELL 3 br, Ranch w/lake privileges finished bsmt, garage, non-smoker, fenced yard, \$975/mo 810-229-7416

HOWELL 2 BR, all new interior, large fenced yard No pets or smokers Lake access, w/dock \$1,100/mo (810)599-5444

HOWELL, 698 Indiana, 3 br, on Thompson Lk 2 full baths, carpet, dishwasher & appliances Attached garage \$1,400/mo 517-404-7737

Homes for Rent 4050

HOWELL All new inside 3 br, 1.5 baths, c.a., 2 car attached garage Full bsmt. All appliances, washer & dryer Deck, 1.5 acres \$1,170/mo 313-218-7744

HOWELL, BRAND-NEW home 3 br, 3 car garage, 1.700sq ft \$1,600/mo (248)549-1188

MILFORD Beauty 5 acres, 3 br, 2 bath, c.a., 2 car, barn \$1850/mo 248-624-5199

MILFORD Option to buy pristine 3 Br basement & garage, in Village, Joe 248-760-4320

NORTHVILLE Country, charming, 1 br, w/decks, basement No pets \$570 248-444-0896

NORTHVILLE Immaculate 3 bdrm, new kitchen and baths, minutes from downtown and schools Bsmt, attached garage, \$1495/mo No pets Agent, Donna 248-347-4411

NOVI, 1 br, w/deck, sunroom, porch, Utilities incl 13 Mile & M-5 \$750/mo (248)824-3443

NOVI 3 br ranch, Appliances Large lot 2 car garage \$1,200/mo Call 248-349-7482

NOVI, DUPLEXES, 43801 Grand River 2 units Rent varies No pets Immediate occupancy Renters pays rent, all utilities, plus 1/2 mo security deposit. Leave message, 248-344-9660, ext. 22

NOVI LAKEFRONT On all sports lake, 2 bdrm, 1 bath, immediate occupancy \$950/mo 248-240-6232

PINCKNEY-2 BR, 1 BATH \$650/mo Pets O.K. Call, (586) 531-6720

PINCKNEY Chain of Lakes, 1500sq ft, 4 br, attached heated garage, all appliances, \$1250/mo 517-404-9221

PINCKNEY SCHOOLS 3 br ranch, 2 baths, full bsmt., 2 car garage, No pets \$1100/month + security dep 734-878-6583

West Bloomfield Lakefront, 3 bdrm, 2 bath, new kitchen, wood floors, bsmt, garage \$1255/mo 248-360-3887

Lakefront/Waterfront Homes Rental 4060

BRIGHTON, 4-5 br, 2 1/2 baths, office/family room, great fishing, 586-795-9550

BRIGHTON/Fonda lake, 1 br, near US23 & Grand River \$650/mo (810)229-9844

BRIGHTON Home for rent on Woodland Sports Lake 810-227-9407

HOWELL, PLEASANT LAKE, (by Howell Nature Center) 2 br, 1 bath, 1/3rd of an acre, 52 lake frontage Avail immediately (517)540-9613

HOWELL, Thompson Lake 2 br, 1 bath, with walkout \$1,100/mo (248)421-3344

ISLAND LAKE - BRIGHTON Small 2 Bedroom house, lake privileges, \$750/mo 734-878-5990

PORTAGE LK. access. Cute 2 br home, oak floors \$615 + No dogs 810-231-2872

WALLED LAKE, 4 br, 3 car garage, fireplace, fenced Rd \$1285/mo 248-624-4673

Mobile Home Rentals 4070

BRUISED CREDIT O.K. + 3br, 2 bath, appliances included Lease with option \$650-\$850, includes lot rent, Beautiful Fenton country side, Min now from all conveniences a Call now 810-714-1200 Tyronewoods.net

Living Quarters To Share 4120

BRIGHTON/HOWELL - Fireplace, hot tub, pond, beach, waterfront, woods & wildlife Share home 50/50 \$600/mo 517-404-1777

MILFORD Responsible person to share new home 2400 sq ft. Private br, bath, & loft. No Smoking/Pets \$600/mo incl. utilities (248) 459-1995

NOVI - FAIRLANE MOTEL AAA deluxe rooms. Daily & weekly rates Cable, fridge & microwave. Free local calls & wireless internet. (248)347-9999

SOUTH LYON, \$80 per week, Private bath & kitchen Call (248)486-7074

SOUTH LYON Your own room (16 x13) w/walk-in closet, shared bath in 3500 sq ft. home on 5 secluded wooded acres located btwn. South Lyon & Ann Arbor \$400/mo & sec Non-smoker, No pets 248-486-8799/248-431-7054

Office/Retail Space For Rent/Lease 4220

BRIGHTON, 1000sq ft, & 700sq ft, 100% visibilty on Grand River (810)333-1915

Help Wanted-General 5000

Help Wanted-General 5000

Help Wanted-General 5000

Help Wanted-General 5000

Help Wanted-General 5000

Help Wanted-General 5000

Help Wanted-General 5000

Help Wanted-General 5000

Help Wanted-General 5000

Help Wanted-General 5000

Help Wanted-General 5000

Help Wanted-General 5000

Help Wanted-General 5000

Help Wanted-General 5000

Office/Retail Space For Rent/Lease 4220

BRIGHTON - 2500 SQ FT Prime office space on corner of Grand River & Brighton Lk. Rd. Located in River Heights Bldg., 565 E Grand River, Call Esther at 810-229-6323

BRIGHTON, DOWNTOWN Nice 1 room office, \$200/mo incl utilities (810)494-1100

BRIGHTON Overlooking Main St. 2 Person Office 375 sq ft Utilities incl \$495/mo 810-227-7107

HOWELL, APPROXIMATELY 3000sq ft office/retail/warehouse for lease w/bay door. Great location (517)548-9741

MILFORD DOWNTOWN Office/retail, 300-2500 sq ft, private parking avail Low rent. Larry, (800) 860-0010

NORTHVILLE DOWNTOWN Executive Office Suites Flexible Lease Terms 248-347-6811

SOUTH LYON Professional space avail. Share fully equipped lab office Lawyer preferred but will consider other professionals Call for details 248-756-3939

WEST BLOOMFIELD LEASE 1200 sq ft 6250 Orchard Lk. Rd. Brand new w/signage Office/meeting. 248-932-3733

Commercial/Industrial For Rent/Lease 4230

BRIGHTON, OFFICE/HEATED warehouse combo w/overhead door 2,100sq ft. Under \$7.00 per sq ft. (248)505-9122

GREEN OAK TWP, 1600 sq ft. Industrial Building on 1 acre 3 Phase / Overhead / Office Exposure to US-23 2100 to 24000 sq feet, Industrial Building, 3 Phase, Docks, Overhead, Beautiful Offices, Just off US-23 20th CENTURY REALTY 810-231-3300

HOWELL-Light Industrial 10,000 sq ft. shop space w/ cranes 28 ceiling 200-1500 sq ft. office space Starting at \$3.95/sq ft. 517-546-8755

NOVI - 1/2 building 3500sq ft, shop & office Simple rent no triple net. (248) 347-0930

SOUTH LYON FOR LEASE Light industrial 2000 sq ft., \$1000/mo 248-756-3939

5000-5980 EMPLOYMENT/SERVICES

Help Wanted-General 5000

Help Wanted-General 5000

Help Wanted-General 5000

Help Wanted-General 5000

Help Wanted-General 5000

Help Wanted-General 5000

Help Wanted-General 5000

Help Wanted-General 5000

Help Wanted-General 5000

Help Wanted-General 5000

Help Wanted-General 5000

Help Wanted-General 5000

Help Wanted-General 5000

Help Wanted-General 5000

Help Wanted-General 5000

Help Wanted-General 5000

Help Wanted-General 5000

Help Wanted-General 5000

Help Wanted-General 5000

Help Wanted-General 5000

Help Wanted-General 5000

Help Wanted-General 5000

Help Wanted-General 5000

Help Wanted-General 5000

Help Wanted-General 5000

Help Wanted-General 5000

Help Wanted-General 5000

Help Wanted-General 5000

Help Wanted-General 5000

Help Wanted-General 5000

Help Wanted-General 5000

Help Wanted-General 5000

Help Wanted-General 5000

AUTO HAULER Exp preferred, CDL Class A. Local & long distance runs. Good pay/benefits. Fax name, phone/resume to 517-548-9935, or e-mail to jame@accurateautocarriers.com

AUTO PAINT & BODY TECH Full time, experienced, for small shop in Hamburg Call 248-770-5300

AVON-Join the Winning Team! Start for as little as \$10 - No inventory needed Call 477-225-3078

AWESOME MACHINE OPERATORS NEEDED! Previous production machine op exp required. Must have great counting math, inspection & organizational skills \$9/hr to start. Applications accepted Monday-Thursday 8:30am-10:30am & 1:30pm-3:30pm Performance Personnel 49366 W Pontiac Trail Wixom, MI 48366 (248)960-9040

BENCH HAND/MILL HAND Experienced with conventional machining. Will consider training. Right person Full-time with benefits Fax (248) 684-0688, apply in person at 4978 Technical Dr, Milford or e-mail qualstaffing@comcast.net

BRIDGEPORT MILL Operator needed for small detail work. 3 to 5 yrs exp. Overtime good benefits. Apply at 29181 Beck Rd, Wixom, MI 48386 6092 or fax to 248-449-6096

CANDY MAKER BRIGHTON AREA CHOCOLATE PLANT SEEKS FULL TIME HELP IN PRODUCTION APPRENTICE POSITION-WILL TRAIN FOOD EXPERIENCE HELPFUL SOME HEAVY LIFTING REQUIRED OPPORTUNITY FOR ADVANCEMENT CALL (248)486-0055

DOG GROOMER NEEDED Experienced Flexible hours Nice working environment. (810) 225-0599

DONT YOU want a job that you can retire with? Women seeking a reliable, focused fast learner with some electrical & mechanical ability to grow with. Position involves loading, unloading, operating/maintaining PVD coating machines & inspecting parts \$10/hr. to start. Experience in industrial tooling, vacuum equipment or related industry is preferred. Applications accepted Monday-Thursday 8:30am-10:30am & 1:30-3:30pm. Performance Personnel 49366 W. Pontiac Trail Wixom, MI 48366 (248)960-9040

DRIVER - KNIGHT TRANSPORTATION Our regional runs are back! Out 5-6 days, home 2 No-touch freight, top-notch equip., daily pay, trailer tracking... call us, it gets even better... 888-346-4639 www.knighttransportation.com Class-A CDL/A months OTR.

ELECTRICAL JOURNEYPerson Licensed or Master Electrician and Apprentices. Full time. Please fax resume to 248-889-1674

EXP. COOK, CARE PROVIDER & HOUSEKEEPER for A Caring Hand at Home, LLC at Oakhaven Manor, 1320 Ashbury Lane, Howell Call 517-546-1547.

Help Wanted-General 5000

WAREHOUSE/PICK & PACK Growing business in Wixom area is looking for individuals who like to be on the move...

WINDOW CLEANER Exp preferred, but will train. Must be dependable, hard working & have reliable transportation...

Help Wanted-Computer/Info Systems 5000

SECURE A FUTURE IN COMPUTER TECHNOLOGY Now accepting trainees for IT training program to earn industry standard IT certifications...

Help Wanted-Office Clerical 5020

ADMINISTRATIVE ASSISTANT Full-time Milford based insurance agency seeking experienced Administrative Assistant to support Senior VP...

ADMINISTRATIVE ASSISTANT Full-time Milford based insurance agency seeking experienced Administrative Assistant to support Senior VP...

RESPONSIBILITIES include Correspondence with high level executives nationwide, coordination of meetings, preparing PowerPoint presentations, making travel arrangements...

Qualifications Must have strong team player mentality, detail-oriented & strong organizational skills, along with advanced Microsoft Office skills...

We offer competitive wages and a comprehensive benefit package. For consideration, please email resume to mfinch@biginc.com

ADMINISTRATIVE ASSISTANT Established construction company located in Brighton has an opening for a multi-talented and dependable administrative assistant...

GENERAL OFFICE / ACCOUNTING Experience necessary. Must know Quickbooks, Exec. Pay & benefits. Fax resume to 734-449-9140...

OFFICE MANAGER Bookkeeping & computer skills required. Part-time approx. 12 hrs/week. Fax resume to 248-380-9342

Help Wanted-Engineering 5030

CIVIL ENGINEER TECHNICIAN Needed for a design/build firm, to aid in commercial site planning including the design of stormwater management systems...

Service/Application Engineer Electrical/Electronics Degree Required. AS or BS will be considered. Position involves applications support, testing and field support...

Help Wanted-Dental 5040

DENTAL ASSISTANT Full-time, Experienced. Please fax resume to (810) 225-0033

DENTAL RECEPTIONIST South Lyon office seeking individual with knowledge of dental insurance. Full time benefits. Call 248-437-4110

Help Wanted-Medical 5060

CERTIFIED MEDICAL ASSISTANT Part time, pleasant/warm to multi task. For Highland Family Practice. Fax resume to 248-889-2696

DIRECT CARE ASSISTANT Make a difference in someone's life. Support special population adults. We will train. \$8.08 plus good benefits. 248-437-7535

Help Wanted-Medical 5060

FRONT DESK/MEDICAL ASST. Internal Medicine. Part time. Exp. Ann Arbor Office. Fax 734-973-4810

Help Wanted-Medical 5060

PODIATRIST ASSISTANT Commerce area, experience preferred. Will train right individual. Part time. Fax to 248-355-1784

Help Wanted-Medical 5060

RN/LPN A \$3,000 bonus! Full and Part-time hours available in our long term care facility located in Farmington. Differentials for Vent Unit, PM shift, Midnight shift & Weekends. Excellent Benefits Package.

Help Wanted-Medical 5060

SECURE A FUTURE IN MEDICAL BILLING AND CODING Candidates needed for training program to achieve industry standard certifications...

Help Wanted-Medical 5060

VETERINARY HOSPITAL POSITIONS Our team is looking for compassionate, self-directed individuals for full time positions in Nov for Vet Assistant, Licensed Vet Tech & Receptionist...

Help Wanted-Medical 5060

LICENSSED CNA Full & Part time Days-Afternoons and Midsnights. Apply at West Hickory Haven, 3310 W. Commerce Rd. Milford 248-685-1400

Help Wanted-Medical 5060

LASER HAIR REMOVAL TECHNICIAN Experienced only, pay commensurate with exp. Resume a2ormer@aol.com or fax 734-996-8767

Help Wanted-Medical 5060

LICENSSED CNA Full & Part time Days-Afternoons and Midsnights. Apply at West Hickory Haven, 3310 W. Commerce Rd. Milford 248-685-1400

Help Wanted-Medical 5060

WAREHOUSE/PICK & PACK Growing business in Wixom area is looking for individuals who like to be on the move...

WINDOW CLEANER Exp preferred, but will train. Must be dependable, hard working & have reliable transportation...

Help Wanted-Computer/Info Systems 5000

SECURE A FUTURE IN COMPUTER TECHNOLOGY Now accepting trainees for IT training program to earn industry standard IT certifications...

Help Wanted-Office Clerical 5020

ADMINISTRATIVE ASSISTANT Full-time Milford based insurance agency seeking experienced Administrative Assistant to support Senior VP...

ADMINISTRATIVE ASSISTANT Full-time Milford based insurance agency seeking experienced Administrative Assistant to support Senior VP...

RESPONSIBILITIES include Correspondence with high level executives nationwide, coordination of meetings, preparing PowerPoint presentations, making travel arrangements...

Qualifications Must have strong team player mentality, detail-oriented & strong organizational skills, along with advanced Microsoft Office skills...

We offer competitive wages and a comprehensive benefit package. For consideration, please email resume to mfinch@biginc.com

ADMINISTRATIVE ASSISTANT Established construction company located in Brighton has an opening for a multi-talented and dependable administrative assistant...

GENERAL OFFICE / ACCOUNTING Experience necessary. Must know Quickbooks, Exec. Pay & benefits. Fax resume to 734-449-9140...

OFFICE MANAGER Bookkeeping & computer skills required. Part-time approx. 12 hrs/week. Fax resume to 248-380-9342

Help Wanted-Engineering 5030

CIVIL ENGINEER TECHNICIAN Needed for a design/build firm, to aid in commercial site planning including the design of stormwater management systems...

Service/Application Engineer Electrical/Electronics Degree Required. AS or BS will be considered. Position involves applications support, testing and field support...

Help Wanted-Dental 5040

DENTAL ASSISTANT Full-time, Experienced. Please fax resume to (810) 225-0033

DENTAL RECEPTIONIST South Lyon office seeking individual with knowledge of dental insurance. Full time benefits. Call 248-437-4110

Help Wanted-Medical 5060

FRONT DESK/MEDICAL ASST. Internal Medicine. Part time. Exp. Ann Arbor Office. Fax 734-973-4810

Help Wanted-Medical 5060

PODIATRIST ASSISTANT Commerce area, experience preferred. Will train right individual. Part time. Fax to 248-355-1784

Help Wanted-Medical 5060

RN/LPN A \$3,000 bonus! Full and Part-time hours available in our long term care facility located in Farmington. Differentials for Vent Unit, PM shift, Midnight shift & Weekends. Excellent Benefits Package.

Help Wanted-Medical 5060

SECURE A FUTURE IN MEDICAL BILLING AND CODING Candidates needed for training program to achieve industry standard certifications...

Help Wanted-Medical 5060

VETERINARY HOSPITAL POSITIONS Our team is looking for compassionate, self-directed individuals for full time positions in Nov for Vet Assistant, Licensed Vet Tech & Receptionist...

Help Wanted-Medical 5060

LICENSSED CNA Full & Part time Days-Afternoons and Midsnights. Apply at West Hickory Haven, 3310 W. Commerce Rd. Milford 248-685-1400

Help Wanted-Medical 5060

LASER HAIR REMOVAL TECHNICIAN Experienced only, pay commensurate with exp. Resume a2ormer@aol.com or fax 734-996-8767

Help Wanted-Medical 5060

LICENSSED CNA Full & Part time Days-Afternoons and Midsnights. Apply at West Hickory Haven, 3310 W. Commerce Rd. Milford 248-685-1400

Help Wanted-Medical 5060

WAREHOUSE/PICK & PACK Growing business in Wixom area is looking for individuals who like to be on the move...

WINDOW CLEANER Exp preferred, but will train. Must be dependable, hard working & have reliable transportation...

Help Wanted-Computer/Info Systems 5000

SECURE A FUTURE IN COMPUTER TECHNOLOGY Now accepting trainees for IT training program to earn industry standard IT certifications...

Help Wanted-Office Clerical 5020

ADMINISTRATIVE ASSISTANT Full-time Milford based insurance agency seeking experienced Administrative Assistant to support Senior VP...

ADMINISTRATIVE ASSISTANT Full-time Milford based insurance agency seeking experienced Administrative Assistant to support Senior VP...

RESPONSIBILITIES include Correspondence with high level executives nationwide, coordination of meetings, preparing PowerPoint presentations, making travel arrangements...

Qualifications Must have strong team player mentality, detail-oriented & strong organizational skills, along with advanced Microsoft Office skills...

We offer competitive wages and a comprehensive benefit package. For consideration, please email resume to mfinch@biginc.com

ADMINISTRATIVE ASSISTANT Established construction company located in Brighton has an opening for a multi-talented and dependable administrative assistant...

GENERAL OFFICE / ACCOUNTING Experience necessary. Must know Quickbooks, Exec. Pay & benefits. Fax resume to 734-449-9140...

OFFICE MANAGER Bookkeeping & computer skills required. Part-time approx. 12 hrs/week. Fax resume to 248-380-9342

Help Wanted-Engineering 5030

CIVIL ENGINEER TECHNICIAN Needed for a design/build firm, to aid in commercial site planning including the design of stormwater management systems...

Service/Application Engineer Electrical/Electronics Degree Required. AS or BS will be considered. Position involves applications support, testing and field support...

Help Wanted-Dental 5040

DENTAL ASSISTANT Full-time, Experienced. Please fax resume to (810) 225-0033

DENTAL RECEPTIONIST South Lyon office seeking individual with knowledge of dental insurance. Full time benefits. Call 248-437-4110

Help Wanted-Medical 5060

FRONT DESK/MEDICAL ASST. Internal Medicine. Part time. Exp. Ann Arbor Office. Fax 734-973-4810

Help Wanted-Medical 5060

PODIATRIST ASSISTANT Commerce area, experience preferred. Will train right individual. Part time. Fax to 248-355-1784

Help Wanted-Medical 5060

RN/LPN A \$3,000 bonus! Full and Part-time hours available in our long term care facility located in Farmington. Differentials for Vent Unit, PM shift, Midnight shift & Weekends. Excellent Benefits Package.

Help Wanted-Medical 5060

SECURE A FUTURE IN MEDICAL BILLING AND CODING Candidates needed for training program to achieve industry standard certifications...

Help Wanted-Medical 5060

VETERINARY HOSPITAL POSITIONS Our team is looking for compassionate, self-directed individuals for full time positions in Nov for Vet Assistant, Licensed Vet Tech & Receptionist...

Help Wanted-Medical 5060

LICENSSED CNA Full & Part time Days-Afternoons and Midsnights. Apply at West Hickory Haven, 3310 W. Commerce Rd. Milford 248-685-1400

Help Wanted-Medical 5060

LASER HAIR REMOVAL TECHNICIAN Experienced only, pay commensurate with exp. Resume a2ormer@aol.com or fax 734-996-8767

Help Wanted-Medical 5060

LICENSSED CNA Full & Part time Days-Afternoons and Midsnights. Apply at West Hickory Haven, 3310 W. Commerce Rd. Milford 248-685-1400

Help Wanted-Sales 5120

Open the door to a NEW CAREER! Real Estate One Let Michigan's #1 real estate broker show you how!

TIME TO CHANGE YOUR LIFE? If you are a career-minded individual, consider becoming a part of our team!

Help Wanted-Sales 5120

SECURE A FUTURE IN COMPUTER TECHNOLOGY Now accepting trainees for IT training program to earn industry standard IT certifications...

Help Wanted-Sales 5120

ADMINISTRATIVE ASSISTANT Full-time Milford based insurance agency seeking experienced Administrative Assistant to support Senior VP...

ADMINISTRATIVE ASSISTANT Full-time Milford based insurance agency seeking experienced Administrative Assistant to support Senior VP...

RESPONSIBILITIES include Correspondence with high level executives nationwide, coordination of meetings, preparing PowerPoint presentations, making travel arrangements...

Qualifications Must have strong team player mentality, detail-oriented & strong organizational skills, along with advanced Microsoft Office skills...

We offer competitive wages and a comprehensive benefit package. For consideration, please email resume to mfinch@biginc.com

ADMINISTRATIVE ASSISTANT Established construction company located in Brighton has an opening for a multi-talented and dependable administrative assistant...

GENERAL OFFICE / ACCOUNTING Experience necessary. Must know Quickbooks, Exec. Pay & benefits. Fax resume to 734-449-9140...

OFFICE MANAGER Bookkeeping & computer skills required. Part-time approx. 12 hrs/week. Fax resume to 248-380-9342

Help Wanted-Engineering 5030

CIVIL ENGINEER TECHNICIAN Needed for a design/build firm, to aid in commercial site planning including the design of stormwater management systems...

Service/Application Engineer Electrical/Electronics Degree Required. AS or BS will be considered. Position involves applications support, testing and field support...

Help Wanted-Dental 5040

DENTAL ASSISTANT Full-time, Experienced. Please fax resume to (810) 225-0033

DENTAL RECEPTIONIST South Lyon office seeking individual with knowledge of dental insurance. Full time benefits. Call 248-437-4110

Help Wanted-Medical 5060

FRONT DESK/MEDICAL ASST. Internal Medicine. Part time. Exp. Ann Arbor Office. Fax 734-973-4810

Help Wanted-Medical 5060

PODIATRIST ASSISTANT Commerce area, experience preferred. Will train right individual. Part time. Fax to 248-355-1784

Help Wanted-Medical 5060

RN/LPN A \$3,000 bonus! Full and Part-time hours available in our long term care facility located in Farmington. Differentials for Vent Unit, PM shift, Midnight shift & Weekends. Excellent Benefits Package.

Help Wanted-Medical 5060

SECURE A FUTURE IN MEDICAL BILLING AND CODING Candidates needed for training program to achieve industry standard certifications...

Help Wanted-Medical 5060

VETERINARY HOSPITAL POSITIONS Our team is looking for compassionate, self-directed individuals for full time positions in Nov for Vet Assistant, Licensed Vet Tech & Receptionist...

Help Wanted-Medical 5060

LICENSSED CNA Full & Part time Days-Afternoons and Midsnights. Apply at West Hickory Haven, 3310 W. Commerce Rd. Milford 248-685-1400

Help Wanted-Medical 5060

LASER HAIR REMOVAL TECHNICIAN Experienced only, pay commensurate with exp. Resume a2ormer@aol.com or fax 734-996-8767

Help Wanted-Medical 5060

LICENSSED CNA Full & Part time Days-Afternoons and Midsnights. Apply at West Hickory Haven, 3310 W. Commerce Rd. Milford 248-685-1400

Help Wanted-Part-Time 5200

ZONING ENFORCEMENT Hiring 2 part time positions. 20hr/week. Code enforcement. Send resume by July 5, 2006 to Rolly Oley, 3191 Hartland Rd., Hartland, MI 48353 or fax to 810-632-6950

MOTHER HAS openings in day care, Mon. thru Fri., 6am to 6pm. Meals provided. References: (248) 349-4898

Help Wanted-Part-Time 5200

CHILD CARE AVAILABLE In South Lyon. Country setting with room to play. Infants thru 8 yrs. Call Barb 248-974-7370

Help Wanted-Part-Time 5200

LOVING NURTURING environment for your child to play & grow. Salem/Novi area. \$3 per hour (248)486-6139

Help Wanted-Part-Time 5200

NANNY/SITTER 8-5:30 pm Mon-Fri, 2 children (4 & 6 yrs) transportation required & references. 248-470-1356 Dawn

Help Wanted-Part-Time 5200

SUMMER PART TIME SITTER for Nov. Must Drive. Call Jan. 248-349-7072

Help Wanted-Part-Time 5200

ELDERLY CARE & ASSISTANCE MILFORD WOMAN offering help to seniors. Light housework & cooking, transportation. ref 12/248-685-3591

Help Wanted-Part-Time 5200

CHILD CARE PROFESSIONAL For infant to preschool ages. part/full time position available. Call Erin at 517-552-2713

Help Wanted-Part-Time 5200

NOV/NORTHVILLE MONTESSORI CENTER Seeks an experienced, AMS-certified Directress for the 2006-07 school year. Experience in a Montessori school required.

NOV/NORTHVILLE MONTESSORI CENTER Seeks a Head Director/Teacher for 2006-07 School Year. Experience in a school setting required. Hours: are 11:00 am to 6:00 pm Monday through Friday. Please send resume to: Novi Northville Montessori 23835 Novi Rd., Novi, MI 48375 or fax to 248-348-3637 or email to nmcc@att.net

NOV/NORTHVILLE MONTESSORI CENTER Seeks a Head Director/Teacher for 2006-07 School Year. Experience in a school setting required. Hours: are 11:00 am to 6:00 pm Monday through Friday. Please send resume to: Novi Northville Montessori 23835 Novi Rd., Novi, MI 48375 or fax to 248-348-3637 or email to nmcc@att.net

NOV/NORTHVILLE MONTESSORI CENTER Seeks a Head Director/Teacher for 2006-07 School Year. Experience in a school setting required. Hours: are 11:00 am to 6:00 pm Monday through Friday. Please send resume to: Novi Northville Montessori 23835 Novi Rd., Novi, MI 48375 or fax to 248-348-3637 or email to nmcc@att.net

NOV/NORTHVILLE MONTESSORI CENTER Seeks a Head Director/Teacher for 2006-07 School Year. Experience in a school setting required. Hours: are 11:00 am to 6:00 pm Monday through Friday. Please send resume to: Novi Northville Montessori 23835 Novi Rd., Novi, MI 48375 or fax to 248-348-3637 or email to nmcc@att.net

NOV/NORTHVILLE MONTESSORI CENTER Seeks a Head Director/Teacher for 2006-07 School Year. Experience in a school setting required. Hours: are 11:00 am to 6:00 pm Monday through Friday. Please send resume to: Novi Northville Montessori 23835 Novi Rd., Novi, MI 48375 or fax to 248-348-3637 or email to nmcc@att.net

NOV/NORTHVILLE MONTESSORI CENTER Seeks a Head Director/Teacher for 2006-07 School Year. Experience in a school setting required. Hours: are 11:00 am to 6:00 pm Monday through Friday. Please send resume to: Novi Northville Montessori 23835 Novi Rd., Novi, MI 48375 or fax to 248-348-3637 or email to nmcc@att.net

NOV/NORTHVILLE MONTESSORI CENTER Seeks a Head Director/Teacher for 2006-07 School Year. Experience in a school setting required. Hours: are 11:00 am to 6:00 pm Monday through Friday. Please send resume to: Novi Northville Montessori 23835 Novi Rd., Novi, MI 48375 or fax to 248-348-3637 or email to nmcc@att.net

NOV/NORTHVILLE MONTESSORI CENTER Seeks a Head Director/Teacher for 2006-07 School Year. Experience in a school setting required. Hours: are 11:00 am to 6:00 pm Monday through Friday. Please send resume to: Novi Northville Montessori 23835 Novi Rd., Novi, MI 48375 or fax to 248-348-3637 or email to nmcc@att.net

NOV/NORTHVILLE MONTESSORI CENTER Seeks a Head Director/Teacher for 2006-07 School Year. Experience in a school setting required. Hours: are 11:00 am to 6:00 pm Monday through Friday. Please send resume to: Novi Northville Montessori 23835 Novi Rd., Novi, MI 48375 or fax to 248-348-3637 or email to nmcc@att.net

NOV/NORTHVILLE MONTESSORI CENTER Seeks a Head Director/Teacher for 2006-07 School Year. Experience in a school setting required. Hours: are 11:00 am to 6:00 pm Monday through Friday. Please send resume to: Novi Northville Montessori 23835 Novi Rd., Novi, MI 48375 or fax to 248-348-3637 or email to nmcc@att.net

NOV/NORTHVILLE MONTESSORI CENTER Seeks a Head Director/Teacher for 2006-07 School Year. Experience in a school setting required. Hours: are 11:00 am to 6:00 pm Monday through Friday. Please send resume to: Novi Northville Montessori 23835 Novi Rd., Novi, MI 48375 or fax to 248-348-3637 or email to nmcc@att.net

NOV/NORTHVILLE MONTESSORI CENTER Seeks a Head Director/Teacher for 2006-07 School Year. Experience in a school setting required. Hours: are 11:00 am to 6:00 pm Monday through Friday. Please send resume to: Novi Northville Montessori 23835 Novi Rd., Novi, MI 48375 or fax to 248-348-3637 or email to nmcc@att.net

NOV/NORTHVILLE MONTESSORI CENTER Seeks a Head Director/Teacher for 2006-07 School Year. Experience in a school setting required. Hours: are 11:00 am to 6:00 pm Monday through Friday. Please send resume to: Novi Northville Montessori 23835 Novi Rd., Novi, MI 48375 or fax to 248-348-3637 or email to nmcc@att.net

NOV/NORTHVILLE MONTESSORI CENTER Seeks a Head Director/Teacher for 2006-07 School Year. Experience in a school setting required. Hours: are 11:00 am to 6:00 pm Monday through Friday. Please send resume to: Novi Northville Montessori 23835 Novi Rd., Novi, MI 48375 or fax to 248-348-3637 or email to nmcc@att.net

NOV/NORTHVILLE MONTESSORI CENTER Seeks a Head Director/Teacher for 2006-07 School Year. Experience in a school setting required. Hours: are 11:00 am to 6:00 pm Monday through Friday. Please send resume to: Novi Northville Montessori 23835 Novi Rd., Novi, MI 48375 or fax to 248-348-3637 or email to nmcc@att.net

NOV/NORTHVILLE MONTESSORI CENTER Seeks a Head Director/Teacher for 2006-07 School Year. Experience in a school setting required. Hours: are 11:00 am to 6:00 pm Monday through Friday. Please send resume to: Novi Northville Montessori 23835 Novi Rd., Novi, MI 48375 or fax to 248-348-3637 or email to nmcc@att.net

NOV/NORTHVILLE MONTESSORI CENTER Seeks a Head Director/Teacher for 2006-07 School Year. Experience in a school setting required. Hours: are 11:00 am to 6:00 pm Monday through Friday. Please send resume to: Novi Northville Montessori 23835 Novi Rd., Novi, MI 48375 or fax to 248-348-3637 or email to nmcc@att.net

NOV/NORTHVILLE MONTESSORI CENTER Seeks a Head Director/Teacher for 2006-07 School Year. Experience in a school setting required. Hours: are 11:00 am to 6:00 pm Monday through Friday. Please send resume to: Novi Northville Montessori 23835 Novi Rd., Novi, MI 48375 or fax to 248-348-3637 or email to nmcc@att.net

NOV/NORTHVILLE MONTESSORI CENTER Seeks a Head Director/Teacher for 2006-07 School Year. Experience in a school setting required. Hours: are 11:00 am to 6:00 pm Monday through Friday. Please send resume to: Novi Northville Montessori 2

Get To **DRIVE CHAMPION DRIVE** Now for our

NO TENT EVENT!



2006 CHEVY SILVERADO EXT CAB 4x4
Auto, V8, OnStar, power windows, power locks. Stk. #16257

\$99 mo. **24** months

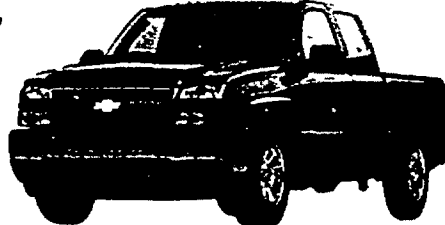

2006 CHEVY TRAILBLAZER LS
Auto, 6 cyl., sunroof, power windows, power locks, OnStar. Stk. #16337X

\$99 mo. **24** months

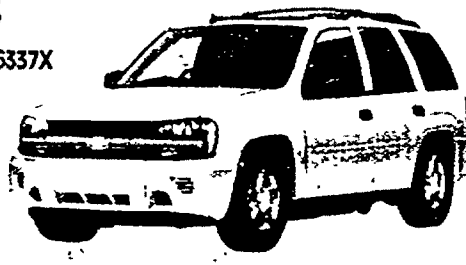

2006 CHEVY IMPALA LT
Auto, V6, power windows, power locks, CD. Stk. #6132

\$84 mo. **24** months



2006 CHEVY MALIBU LS
Auto, 4 cyl., power windows, power locks. Stk. #6128

\$84 mo. **24** months

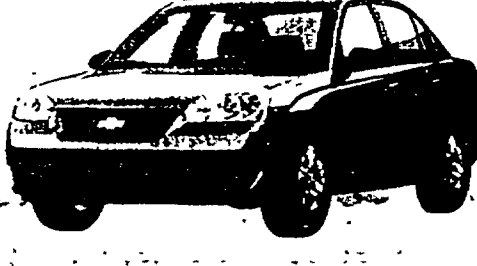

2006 CHEVY COBALT LS
Auto, power locks, CD, spoiler. Stk. #6001

\$83 mo. **24** months



2006 MONTE CARLO LS
Auto, V6, power windows, power locks, CD. Stk. #5932

\$129 mo. **24** months



2006 CHEVY COLORADO CREW CAB
Auto, AC, 5 cyl., CD. Stk. #16303

\$198 mo. **39** months



WE HAVE SO MANY NEW & USED CARS & TRUCKS... NO TENT COULD EVER HOLD THEM ALL!

PRE-OWNED

2006 CHEVY TRAILBLAZER LS 4x4
Power windows, power locks, dual climate. WAS \$22,900
NOW \$19,800



2006 CHEVY IMPALA LT
Alloys, power seat, super sharp. WAS \$21,900
NOW \$18,400



2006 HHR LS
Auto, pwr win/locks, a hard find! WAS \$18,900
NOW \$17,300

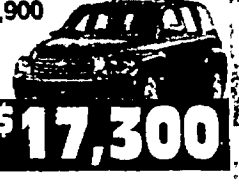

2006 UPLANDER EXT LS
Pwr win/locks, rear buckets. WAS \$20,900
NOW \$18,600



2006 COBALT LT
Pwr win/locks, spoiler, alloys. WAS \$14,900
NOW \$13,200

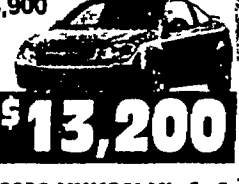

2005 CHEVY COBALT LS
Certified! Power locks/windows, CD, alloys! \$12,900

2003 SATURN VUE AWD
All power options, CD, sporty \$11,900

2003 CADILLAC CTS
Low miles, pampered, loaded with moonroof \$20,500

2001 S10 EXTREME
V6, power locks/windows, well kept. \$11,900

2003 SATURN L200
Power windows/locks, impeccable condition. \$10,500

2004 MONTE CARLO LS
Certified, low miles, superior condition. \$14,800

2000 CHEVY MALIBU
Full power options, CD, alloys, budget car \$7,599

1995 PONTIAC GRAND AM SE
Wow! Priced to fit your budget. \$4,900

2003 MERCURY GRAND MARQUIS
Pure comfort, all power options. \$9,900

2003 CAVALIER LS
Certified, low miles, all power options, CD, alloys, fantastic condition \$8,900

2002 CHEVY BLAZER
Certified! Power locks/windows superior condition. \$10,900

2000 JEEP CHEROKEE SPORT 4x4
Power windows/locks. Ready and able \$9,900

2003 GMC YUKON XL 4x4
Loaded, DVD, perfect family edition. \$25,900

2004 CHEVY TRAILBLAZER LS 4x4
Certified! All power options! \$15,500

2006 FORD FREESTAR SE
A real family pleaser! \$16,500

2005 EQUINOX LS
Well equipped! Certified. \$17,200

2005 IMPALA
Factory warranty, certified. \$13,800

2005 PONTIAC SUNFIRE
Certified, sharp commuter vehicle! \$12,900

2005 PONTIAC VIBE
All power options, sporty car! \$16,099

2004 BUICK RENDEZVOUS CX
Power options, great ride! \$15,300

2004 BUICK RENDEZVOUS CXL
Luxury options, sharp looking! \$16,300

2004 CHEVY VENTURE LS
Extend, rear AC, power options. \$16,200

2003 PONTIAC MONTANA
Super clean, a family must have! \$14,500

1998 OLDS SILHOUETTE
All ready for a family on a budget! \$6,300

THE ONLY THING MISSING IS THE TENT!

OVER 200 USED!

We Finance Everyone! 100% GUARANTEED CREDIT APPROVAL!



AN AMERICAN REVOLUTION

(877) 716-7253
WWW.CHAMPCHEV.COM

All prices and leases based on GM's discount plus tax, title and fees. Leases based on GM's approval. \$3995 down, 10,000 mpy on the Silverado, Trailblazer, Impala, Malibu and Monte Carlo. 12,000 mpy on the Cobalt and Colorado. All incentives applied to dealer's discretion.

www.brightonford.com www.brightonford.com www.brightonford.com www.brightonford.com

OPEN 9-9 MON. THRU THURS. OPEN SAT. 9-4, FRI. 9-7

OPEN 9-9 MON. THRU THURS. OPEN SAT. 9-4, FRI. 9-7

REBATES UP TO \$9500

BRIGHTON

Ford - Mercury

INTEREST RATES AS LOW AS 0% 60 mos.

BIG NEWS!
THE ALL NEW
STAGE 3 ROUSH MUSTANGS
HAVE ARRIVED!
23 Roush Models Available for Delivery!

Just Announced!
\$1,000 GAS CARD
see dealer for details!

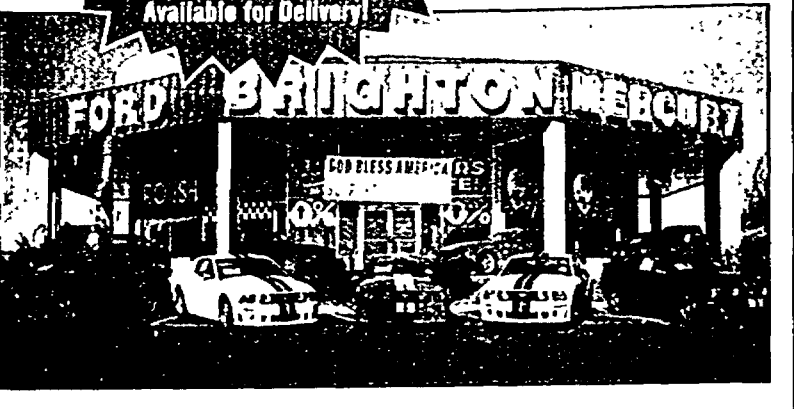

ATTENTION FORD EMPLOYEES AND ELIGIBLE FAMILY MEMBERS ~ NOW IS THE TIME TO USE YOUR PROGRAM HURRY! INCENTIVES END JULY 5th

ESCAPE AND MARINER HYBRIDS IN STOCK

2007 SPORT TRAC XLT 4X4
Completely Redesigned!

Was \$28,765
Now \$24,256

\$171

REBATES UP TO \$2000
x 24 MO. WITH \$2500 DUE



ALL NEW!

Stk. #469
0% FINANCING FOR 60 MOS.

Was \$22,930
Now \$17,879

\$161

REBATES UP TO \$2750
x 24 MO. WITH \$2500 DUE

2006 FOCUS ZX5 SES 5 DR

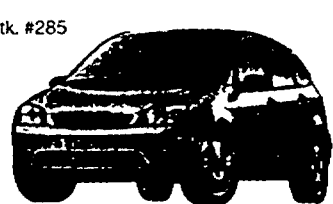

Was \$18,595
Now \$13,447

\$48

REBATES UP TO \$3000
x 24 MO. WITH \$2500 DUE



Was \$32,255
Now \$22,949

\$156

REBATES UP TO \$5500
x 24 MO. WITH \$2500 DUE

2006 F150 SUPERCAB XLT 4x4

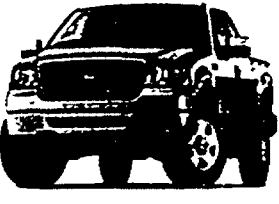

Was \$34,545
Now \$22,275

\$68

REBATES UP TO \$6500
x 24 MO. WITH \$2500 DUE



Was \$25,185
Now \$19,253

\$155

REBATES UP TO \$3000
x 24 MO. WITH \$2500 DUE

2006 MOUNTAINEER LUXURY AWD



Was \$35,145
Now \$25,344

\$150

REBATES UP TO \$5695
x 24 MO. WITH \$2500 DUE



Was \$20,925
Now \$16,756

\$121

REBATES UP TO \$2000
x 24 MO. WITH \$2500 DUE

2006 FUSION SE



Was \$20,990
Now \$16,027

\$79

REBATES UP TO \$2750
x 24 MO. WITH \$2500 DUE



Was \$26,620
Now \$20,086

\$171

REBATES UP TO \$3000
x 24 MO. WITH \$2500 DUE

2006 FREESTYLE LTD



Was \$29,230
Now \$23,421

\$169

REBATES UP TO \$2750
x 24 MO. WITH \$2500 DUE



Was \$27,415
Now \$22,479

\$227

REBATES UP TO \$2000
x 24 MO. WITH \$2500 DUE

2006 MARINER LUXURY 4WD

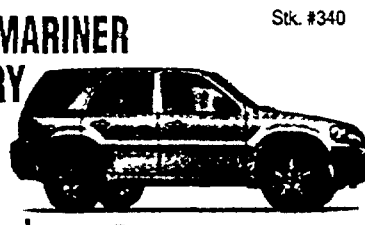

Was \$26,890
Now \$20,776

\$164

REBATES UP TO \$3000
x 24 MO. WITH \$2500 DUE



Was \$25,555
Now \$13,984

\$284

REBATES UP TO \$9500
x 24 MO. WITH \$2500 DUE

Michigan's Largest FORD MERCURY DEALER!



8240 W. Grand River at I-96

1-800-836-7697

Or Buy Online

www.brightonford.com

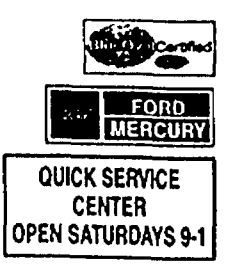

All pricing based on A2 Plan with LHM Petrol Voucher (\$1,000.00) on both purchase or lease. All rebates to dealer including lease renewal program. All pricing plus title, tax, plates. Leases set up at 24 months at 13,500 miles per year. All leases or purchases based on approved credit. All programs subject to change from Ford without notice. Expires July 31 2006.

www.brightonford.com www.brightonford.com www.brightonford.com www.brightonford.com



Submitted Photos

At left, Jeffrey Allen is pictured with his certified international therapy dog, Chyna. Chyna, a doberman, was trained by Allen's wife, Karen, a trainer with Saint Joseph Mercy Hospital rehabilitation unit in Ann Arbor. Below, Allen and Irene Metro, MD, are performing a trigger point injection. At the bottom, Allen and Emily Neff take time to understand each client's physical condition. They create specialized plans appropriate to the individual.



Allen Physical Therapy • Jeffery Allen

(248) 437-2322 • www.allenphysicaltherapy.com

There is physical therapy and there is advanced skilled physical therapy.

If you know anything about Jeffrey Allen, Board Certified Orthopedic Clinical Specialist and owner of Allen Physical Therapy in South Lyon, you know that he practices the latter.

Allen has extensive experience with industrial medicine, sports medicine, and is a current member of the American Physical Therapy Association. He knows there are lots of choices in the physical therapy profession but he knows that what he does sets himself apart from all of the others.

Allen specializes in all types of orthopedic injuries, but one of the most common afflictions he treats is FMS or fibromyalgia syndrome. FMS affects ten million people every year and is characterized by widespread muscle and joint pain with severe fatigue. Fibromyalgia means pain in the muscles, ligaments and tendons — the soft fibrous tissues in the body.

Allen said that FMS can be treated but people often are not

Allen said that most physical therapists treat the more common trigger points, but he has taken the practice a step further, training with some of the world's foremost experts in myofascial pain and trigger point dysfunction.

Although treatment for FMS patients is becoming an integral part of Allen's business, he still maintains an outstanding reputation for his work in manual physical therapy, which is used to correct physiological barriers in the body caused by injury, overuse, or prolonged poor posture.

Examples are restricted connective tissue, tightened or knotted muscles, swollen joints, and misaligned joints, all of which can cause pain, restricted mobility, and function. Allen is a skilled therapist that employs techniques to physically correct and aid in the healing of these problems, resulting in more successful and quicker recoveries. For many

chronic pain patients these manual therapy skills may be their only hope for improvement.

What also makes Allen unique in the physical therapy profession is his personal attention to each patient that walks into his clinic. Each patient meets face-to-face with Allen in the small, high-quality atmosphere of his office on 304 N. Lafayette St., in South Lyon.

"When they come in, I am the one they work with," he said. "I am here creating my own reputation as the sole clinical therapist in the office."

Allen believes in ongoing training and education as a means for offering the best treatment to his patients. He updates his training with advanced courses, seminars, and out-of-town sessions, including specialized training through Pain and Rehabilitation Medicine in Maryland (www.painpoints.com).

Allen Physical Therapy is located in the Lafayette Plaza, one block north of Lake Street. Office hours are 8 a.m. to 7 p.m. Monday through Friday.

— *By John R. Hall*

2006



South Lyon Cycle • Gary Childs



Jim Seghi Renovations • Jim Seghi



Perfect Floors • Ron Williams



Mayfair Realty • Abe Ayoub



Essex Legal • Dennis B. Dubuc



Econo Print • Ted Stilber

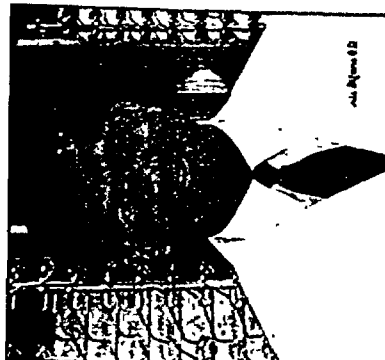

Bifano Family Eye Center
Christopher Bilano, MD

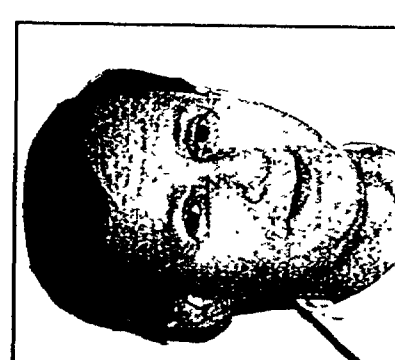

Sam Roseberg, MD, FACS



Ameritrust Realty • John Underwood



Flowers of Novi • Orv Borg



Grand River Dental • Brad Rondeau, DDS



Bistro 127 • Don Waldenmayer

Gentlemen In Business

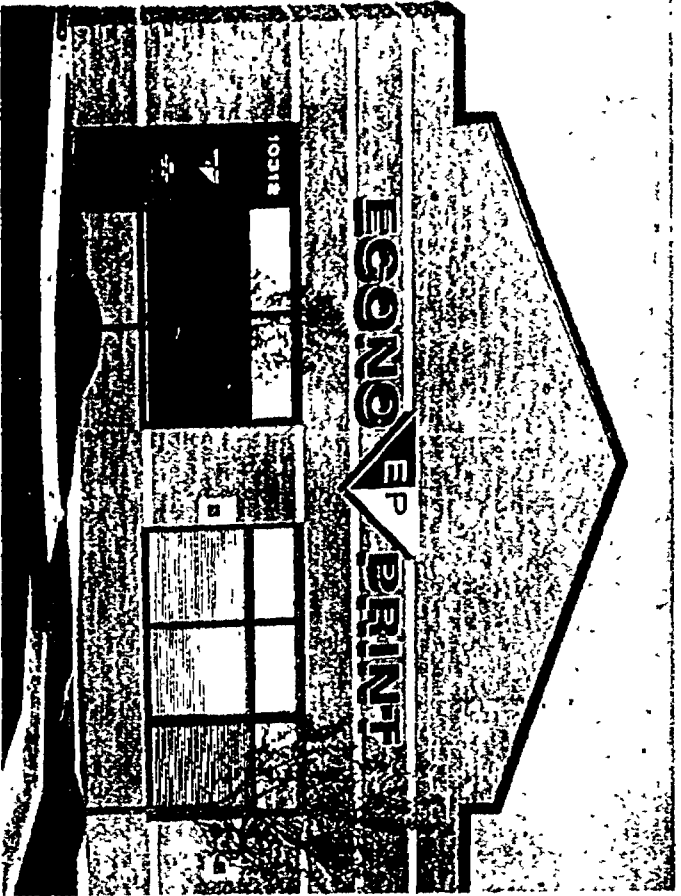

Econo Print offers printing and mailing services for businesses of all sizes. After many years in downtown Pinckney, the company is celebrating its second year in its new facility on Dexter-Pinckney Road.



Ted Stilber proofs a sheet printed on Econo Print's new fully automated Heidelberg Printmaster. Photos by CYNTHIA GROCHOWSKI

Econo Print

(734) 878-5806 • www.econoprintusa.com

Stilber and his team at Econo Print have been serving the business community since 1988, growing in client base and services each year.

"Thanks to the ongoing support of the community we have grown," Ted says. Because of the growth, Stilber has realized his greatest accomplishment in building Econo Print's new facility while staying in Pinckney. The company moved operations from downtown Pinckney to a new, larger facility across from the new Pinckney Community High School in 2004.

Printed materials and direct mailers are still in big demand in the business world and Stilber thrives on rising to the challenge each customer's order brings.

"It's staying current with technology in the ever-changing printing and mailing industry that I like best about the job," he said. Stilber also believes staying current with technology insures customer satisfaction. One of the recent upgrades at Econo Print this year include a new, fully automated Heidelberg Printmaster featuring an infrared dryer.

Another upgrade is making mass mailing jobs more efficient. Econo Print's new Bell & Howell six-station envelope inserter automatically inserts up to six pieces into an envelope as large as 6.5 inches by 9.5 inches.

"We are able to provide more efficient production at a higher quality," Stilber said. Paying attention to what technology can offer his customers, providing it and offering unbeatable personal customer service has grown Econo Print tremendously each year.

The growth is due, in part, to Stilber's personal dedication to getting the job done, including operating the machinery himself at the midnight hour.

Stilber attributes his work ethic to his father-

- TED STILBER**
- Family: Married to Julie for 14 years, with children Katie and Allie
 - Dream vehicle: Bentley Continental GT
 - Hobbies: Golfing and watching NASCAR
 - Community: Pinckney/Lakeland/Hanburg Chamber of Commerce and the Pinckney Merchants Assoc.

In-law Dave who he looks upon as a mentor. "He possesses the qualities that have helped me become successful," Stilber said. "He is hardworking, honest, has great integrity and is always willing to help."

Econo Print provides businesses, both large and small, with a variety of printing services and products including postcards, brochures, newsletters, business cards and fliers.

Econo Print also offers over 500,000 promotional items for company outings or events like coffee mugs, magnets and pens with a business logo. Econo Print accepts completed files in either a PC or Mac format for printing.

On-site graphic design services are available to assist customers in the project layout and design.

"We are able to handle our customers' printing and mailing jobs from the design stage through the mailing process all under one roof," Stilber said.

Direct mailing of advertising material has been a strong suit at Stilber's company, saving customers time and money. Projects can be handled from beginning to end — from design to

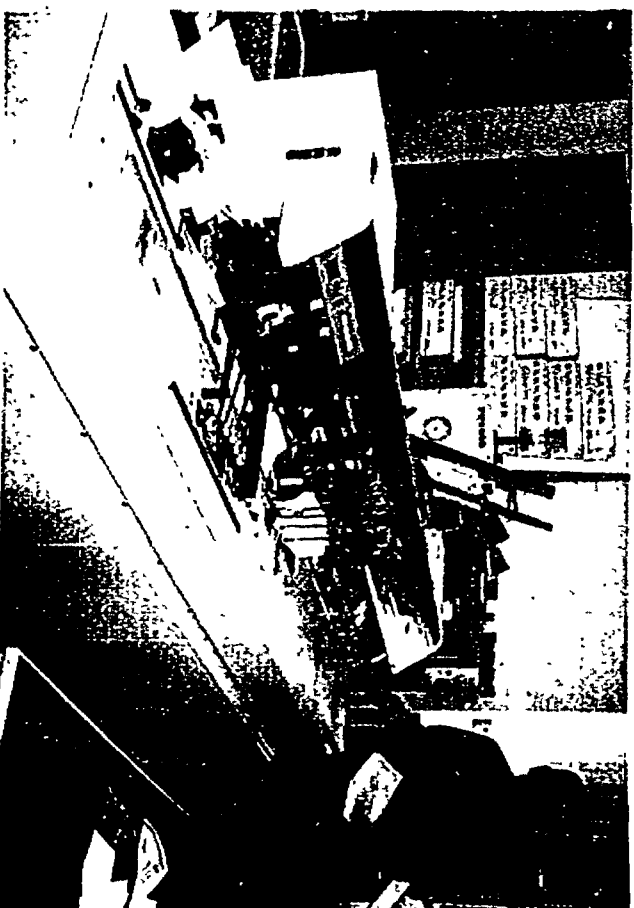

Econo Print constantly upgrades equipment to better service customers. This new Bell & Howell six-station envelope inserter automatically inserts up to six pieces into an envelope as large as 6.5 inches by 9.5 inches.

production — including postage and post office drop. Scheduled or seasonal mailings of bulk mail are also available. Another plus is Econo Print's ability to manage variable data letters when some of the content within a mailing may change.

Stilber's firm is also a mailing list provider offering mailing lists of consumers and other businesses for direct-mail pieces. Automation of a customer's own list is also available.

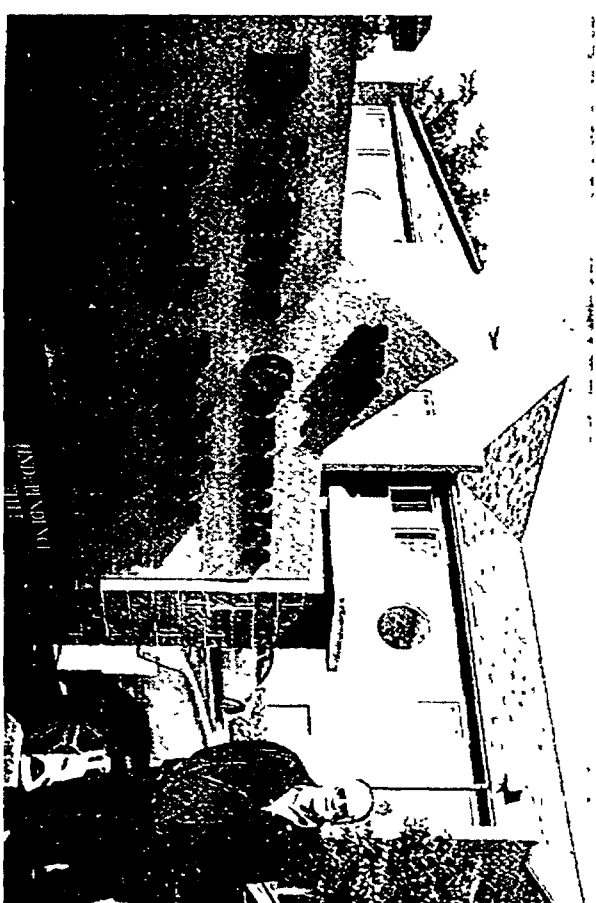

This year Bill Tomlinson celebrates six years as the courier for Brighton Commerce Bank.

Brighton Commerce Bank

(810) 220-1199 • www.brightoncommercebank.com

Within the walls of Brighton Commerce Bank men and women work hard to personally meet the needs of each and every customer that calls or walks into their lobby.

On the road, delivering documents and meeting customers and bank representatives alike, is an important representative of the bank, as well. For the past six years, Bill Tomlinson of Brighton has been the courier for Brighton Commerce Bank, providing a necessary link to the bank for business accounts.

"Traveling around and meeting bank representatives and bank customers is what I like best about this job," Tomlinson said. He looks upon helping maintain good relations with bank customers as one of his greatest accomplishments. Brighton Commerce Bank offers courier service at no charge for all business accounts. Monday through Friday during bank business hours using locked courier bags.

"We are the only bank that offers courier service to our commercial customers," states Gary T. Nickerson, president and CEO. "This saves commercial customers from having to take time away from their businesses to come into the bank."

Many customers enjoy coming into the bank, however, and receiving the exceptional service Brighton Commerce Bank provides.

Brighton Commerce Bank is truly a community bank, attributing its continued, growing success to unrelenting attention to personalized service and a complete array of banking services for every commercial and consumer customer.

"When you come into our lobby you are served promptly," John Szydzik, senior vice president and cashier says. "When the telephone rings, we answer it immediately. Our customers quickly discover every manager and employee is easily approached."

Numerous customers have told bank staff that having a person answering the telephone, instead of an automated message system, is very important to them. Brighton Commerce Bank is a full-service bank and Brighton's only local bank. The staff offers numerous years of banking

- BILL TOMLINSON**
- Family: Married to Jane for 51 years; sons Neil and Dale, daughter Mary
 - Hobbies: Stamp and coin collecting
 - Community: American Legion and Historical Society
 - Dream Car: A mint condition Ford Thunderbird

experience and all of the bank employees reside within the local community.

"Full service means we can do everything, so ask us anything," Nickerson said. "Because we are local, we know our customers and we are more apt to be able to support our customers' requests than the other non-local banks."

Brighton Commerce Bank offers everything from checking and savings accounts to investments, loans, mortgages and 24-hour banking. Free checking is offered to small businesses, seniors, juniors, mortgage customers, direct deposit customers and more.

Banking services also include ATMs, debit cards, direct deposit, overdraft protection, safe deposit boxes, money orders, cashier checks, travelers checks, credit cards, notary services and signature guarantee for bank customers as well as wire transfers.

Thus, and investment services are offered including all the traditional brokerage services such as stocks, bonds, mutual funds and annuities.

Customers with Brighton Commerce Bank have access to their accounts any time and from any location, 24-hours-a-day with telephone banking and internet banking including Online Bill Payment, all at no charge, allowing customers to pay virtually anyone — companies or individuals — at any time.

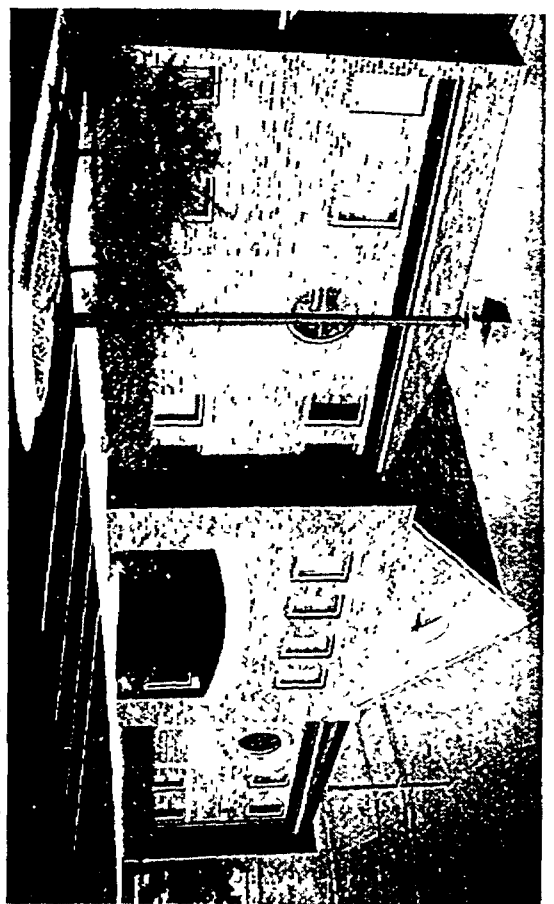

Brighton Commerce Bank is the only bank that offers free courier service for all business accounts Monday through Friday during bank business hours using locked courier bags. Photos by CYNTHIA GROCHOWSKI

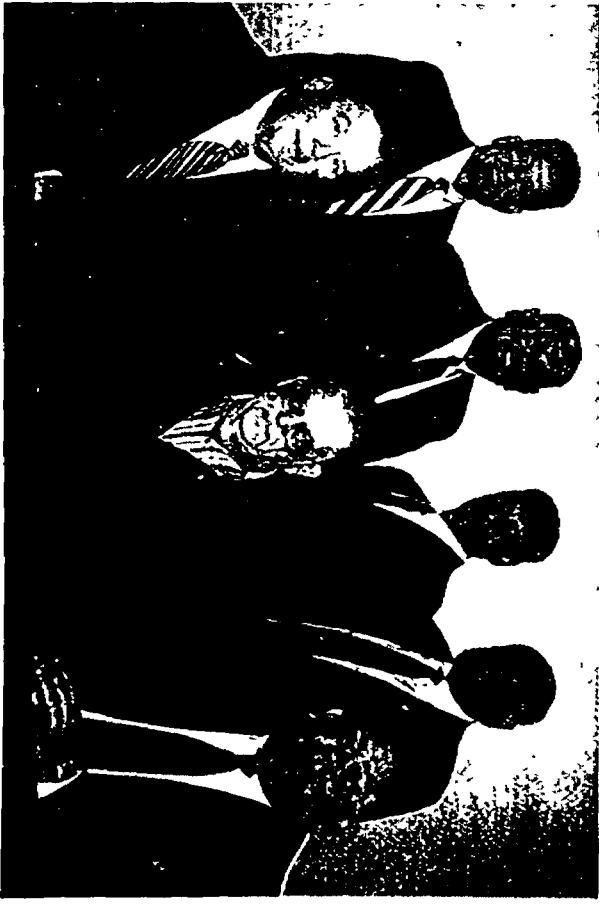

The gentlemen of Brighton Commerce Bank include, from left, Mark R. DuShane, vice president, trust and investment services; Gary T. Nickerson Sr., president and CEO; Corey Ruthig, assistant vice president, commercial lending; William R. Anderson, vice president, commercial lending; front row, from left, John Szydzik, senior vice president and cashier; Bill Tomlinson, bank courier; Joseph M. Petrucci, senior vice president and chief credit officer.

Consumer lending services include automobile and recreational vehicle loans, manufactured homes on foundations, and secured loans. Construction loans, mortgages and lines of credit are available to both personal and commercial customers. Home improvement, home equity loans and lines of credit are available to homeowners.

"We excel in providing construction loans and mortgages for both commercial and residential customers," says Nickerson. Most importantly, Brighton Commerce Bank conducts all of its commercial loan underwriting, approvals, processing and funding in-house. Decisions are made more quickly and with a sense of urgency on behalf of the customer.

"We provide everything the larger banks do, but on a more personal level," notes Szydzik. "Customers appreciate our friendly local staff and the terrific personal service that they provide. Customers genuinely enjoy banking here." "Our philosophy is to exceed customer expectations, not just to meet them," adds Nickerson. "You won't believe the difference. This is banking as it should be."

Brighton Commerce Bank is located at 8700 N. Second St., in Brighton. They are open 9 a.m. to 5 p.m. Monday through Friday and 9 a.m. to noon Saturday. The drive-in window is open until 6 p.m. on Thursday and Friday.

Little Archie's • Mike Palushaj (248) 437-3065

With his history of several restaurants and many years of hard work behind him, one thing has stayed consistent for Mike Palushaj, owner of Little Archie's — when he was 24 years old he set a goal to own his own business.

Today that dream has been realized in the shape of Little Archie's restaurant. Even better for Mike is a third restaurant that will be opening in Brighton in the Green Oak Village Mall in October with the same menu and same family friendly tradition started by Mike and his brother.

"I told myself and my children, 'If you are willing to work hard you will never starve,'" Mike explained.

He and his brother opened and owned the first Archie's in Livonia in 1980. Today Mike is happy to have his wife Olga and children Valentin, Christin, Anton, and Jonathan, and his daughter-in-law Maria working side-by-side serving South Lyon's finest home cooked

meals. The menu Mike offers the customers at Little Archie's is such a variety of choices, that they continue to return again and again to try something new. This fact, and Mike's personality, make the dining experience a family event.

"More than 90 percent of the customers know me and get a handshake when they come here to eat," Mike said. "Even a lot of the people from the Livonia Archie's come out to see us and say hi."

Who is Little Archie? Mike smiled and answered, "Archie? Oh, that is me. My friends used to call me little Archie, like Archie Bunker." His friends, family and customers do appreciate his warmth and sense of humor.

Share the experience at Little Archie's on 20889 Pontiac Trail, just north of Eight Mile. The restaurant is open from 6 a.m. to 9 p.m. Monday through Saturday, and from 6 a.m. to 8 p.m. Sunday.

— By Michael Pilotti



Photo by MICHAEL PILOTTI
Mike Palushaj, left, and his son Valentino are looking forward to opening a new place in Brighton.

Flowers of Novi • Orv Borg (248) 380-8250 • www.flowersofnovi.com

He has redone the store and former customers probably wouldn't recognize the changes. But they will enjoy visiting with the staff and Borg's therapy dog, Nanook, a Siberian Husky.

In the short period of time since opening, his business has been voted "Best Floral Shop of 2006" by readers of The Novi News. Active in giving back to the community through many service projects, Borg recently helped sponsor a local bowl-a-thon.

Borg sells a lot of gift items besides flowers, too. These items include fruit and gourmet baskets, balloons, figurines, Beanpod candles, blown glass ornaments, and stuffed animals. Flowers of Novi has special wedding, funeral, and corporate packages, too.

"Flowers make you feel better," Borg added. "They pick you up."

Flowers of Novi is located at 24261 Novi Road, in Novi.

— By John R. Hall

"Flowers make you feel better. They pick you up."

— Orv Borg
Owner of Flowers of Novi

Borg understands that people can buy flowers from many different places and not only does uniqueness matter, but so does customer service. He said his staff strives for "good of fashion" service.

"A lot of places treat customers as more of a burden," Borg added. "We need customers or we would be out of business." Borg took over the former "Flowers of VI" in October 2005, relocating from his Beanpod Candles, at Flowers of Novi.

It shouldn't take a special occasion like a wedding or anniversary to bring out the beauty and inspiration of fresh flowers.

"Just because" is the perfect occasion for a beautiful floral arrangement.

That's the philosophy of Orv Borg, owner of Flowers of Novi. Borg believes in the European philosophy that fresh flowers around the home every day makes people feel good. And he has the experience to create just the special arrangement to bring out that effect.

"We try to be very unique with our arrangements," he said. "What you buy from us should be different from everyone else."

Orv Borg and his Siberian Husky therapy dog, Nanook, offer custom flower arrangements and a variety of gift items, including Beanpod Candles, at Flowers of Novi.



Photo by USA TODAY

Essex Park Law Office • Dennis B. Dubuc, Attorney at Law (248) 486-5508

who was bitten by a dog on the man's property.

But the elderly man didn't own the dog. He could have lost his home in the court battle but Dubuc helped him defeat the lawsuit.

In the other example, Dubuc was asked by a woman to file a wrongful discharge suit concerning her employment.

The matter was settled without going to court and the woman was pleased with the settlement.

"Many cases can be very difficult, especially child custody cases," he added. "That's why people need someone who cares — to help them."

Dennis B. Dubuc, Attorney at Law, can be found at Essex Park Law Office, P.C., 12618 Ten Mile Road, in South Lyon. Call (248) 486-5508.

— By John R. Hall



Photo by JOHN HALL

Dennis B. Dubuc has a fully equipped law office in Green Oak Township.

South Lyon Cycle • Mark & Gary Childs (248) 437-0500

As the owners and operators of South Lyon Cycle, the Childs brothers are devoted to bikes.

South Lyon Cycle stocks a large selection of bicycles at great values. Mountain, Comfor, Hybrid, Road Cruiser, Recumbent, BMX, Freestyle, and Juvenile bicycles, from top brands including Trek, Gary Fisher, Giant, Electra, Townie, Haro and G.T. are offered with expert assembly of all bikes.

Bikes are offered in a variety of sizes including 12-inch, 16-inch, 20-inch and 24-inch wheel bikes for children as well as adult models in many frames and sizes.

Customers are sold a bike that meets their needs with proper fit for comfort and safety emphasized.

Helmets are recommended and correct sizing and fit for safety and comfort is free. South Lyon Cycle offers an extensive parts inventory and popular accessories — including trailers, pedal trailers, child carriers, bike carriers and women's and men's gel comfort saddles. Cross footwear and Life is good casual wear are also now in stock.

One-day repair services are available on all brands. Tune-ups are a specialty for better performance and safety of any bike.

South Lyon Cycle sponsors two charitable events — The

American Diabetes Association Tour de Cure and The Multiple Sclerosis Society MS 150.

South Lyon Cycle is located in downtown South Lyon at 209 S. Lafayette (Pontiac Trail), two blocks south of Ten Mile — minutes from Island Lake State Recreation area, Kensington Metropark, Huron Valley Trail System and South Lyon's Rail Trail.

Hours are Monday through Friday 10 a.m. to 7 p.m. and Saturday 10 a.m. to 5 p.m.

Mark, left, and Gary offer quality bikes, one-day repair service, tune-ups and more at South Lyon Cycle.

Photo by MICHAEL PILOTTI

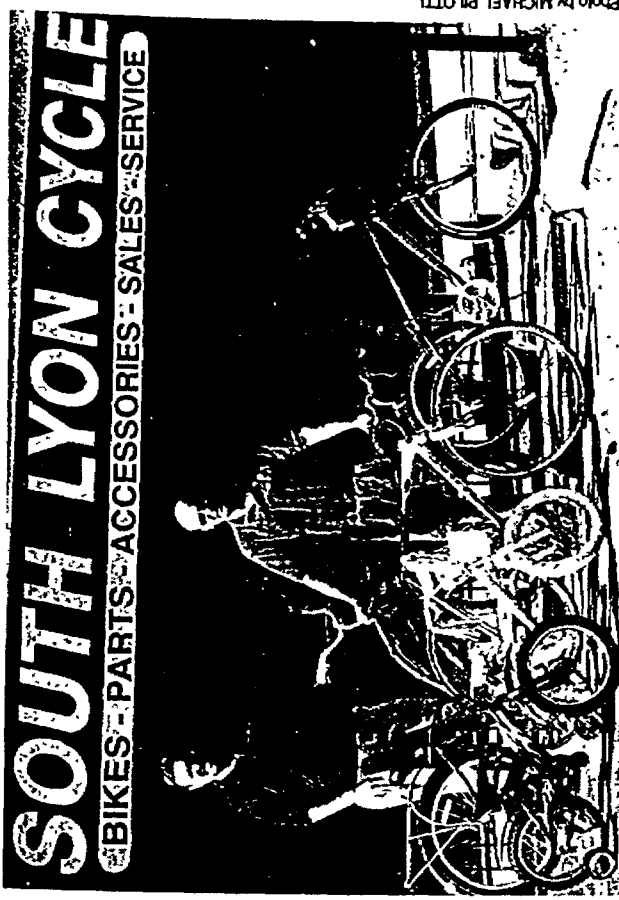

Quality Insurance Services • Dave Grimes, Sr. and Don Beck (248) 437-1700

Use most of the time. And then there are special occasions when we utilize other companies."

Beck handles the personal lines of insurance — auto, home, recreation. Grimes manages all the commercial accounts.

"The insurance industry is changing, but the needs of the people stay the same," Beck said. "Protect your assets is my advice to people."

Both men remember when they would make house calls to write a policy. Now, they say, most of their business is done over the Internet, phone, or fax machine. Busy schedules leave little time for kitchen table meetings.

Representing multiple insurance companies allows Quality

Insurance the opportunity to provide a customer four or five quotes, to choose from. Some companies prefer, or are more suited to, specific types of insurance. Beck said a tool and die shop, for instance, may find a better rate with one company because they already have policies written for that industry and prefer that type of customer.

"Our commercial accounts can be as varied as home builders, truckers, bakeries, and any main street business," Grimes said.

The two owners operate their business from a small-town approach, especially since Beck and Grimes came from small towns.

"Providing service, friendliness and trust is the way we like to conduct business," Beck said. Quality Insurance Services is located at 214 S. Lafayette St., in South Lyon.

— By Nathan Merriam

DAVE GRIMES, SR.
Hobbies: Church, family, granddaughter and golf

DON BECK
Hobbies: Spending time in his place up north, fishing, hunting and snowmobiling

Inside Gentlemen in Business 2006

Allen Physical Therapy	Flowers of Novi	Our Place to Yours
AmeriTrust Realty • John Underwood	Gannett Newspapers	Perfect Floors
Bakman Florist of South Lyon	Grand River Dental	Attorney At Law • Philip J. Weipert
Bifano Family Eye Care	Huron Valley State Bank	Quality Insurance Services
Bistro 127	Jim Seghi Renovations	Robert Brateman, MD • Peter Bullach, MD
Brighton Commerce Bank	Legal Counsel, P.C.	Sam Roseberg, MD, F.A.C.S.
DigiComm Electronics, Inc.	Little Archie's	South Lyon Cycle
Econo Print	Lyon's Mini Mart & BP Gas Station	Specialists in Orthopedic Surgery
Essex Park Law Office • Dennis B. Dubuc	Mayfair Realty	Town-n-Country Bikes and Killer Paintball 6

Our Place To Yours • The Goodlaski Men

Harland (810) 632-4433 • Milford (248) 684-9017
www.ourplacetoyours.com



Photo by DEB GOODLASKI

Amid some beautiful furniture at Our Place To Yours are, from left, standing, sons Tim and Rick Goodlaski and father Rick Goodlaski. Seated is son (and future mover) John Goodlaski.

Our Place To Yours offers new and quality used furniture, home accents and collectibles including Ashley, Thomasville, Ethnik Allen, Norman Rockwell and Boyd's Bears, just to name a few.

Our Place To Yours, opened eight years ago in Harland, was the first furniture consignment store in Livingston County and now is the largest with the addition of its second location in Milford opened almost two years ago.

The success of the business has been helped along greatly by the Goodlaski men.

As partner with wife Deb, Rick Goodlaski helps with the furniture moving whenever needed, and works

as finance manager at Krug Ford Lincoln Mercury in Howell. Oldest son Rick, a sophomore at MSU, has worked at the store since 1999 unloading and assembling new Ashley furniture, and currently helps with evening and weekend pickups and deliveries of consignments and new furniture.

Tim, a freshman at MSU in the fall, has worked in the store since 2000 also unloading and assembling new Ashley furniture, and picking up and delivering consignments and new furniture.

John has finished 2nd grade at Creekside Elementary in Harland. John spent his first five years helping Mom at the store.

The Web site, www.ourplacetoyours.com, provides a look for both shoppers and sellers at some of the beautiful items available at each store, and offers a link to the Ashley furniture web site.

Our Place To Yours is located at 10534 Highland Road, (M-59) just east of U.S.-23, behind McDonald's in Harland, and at 143 S. Milford Road, in the new Farmer Jack plaza behind Wendy's, in Milford.

Both stores are open 10 a.m. to 6 p.m. Monday, Wednesday and Friday; 10 a.m. to 8 p.m. Tuesday and Thursday; 10 a.m. to 5 p.m. Saturday; and noon to 5 p.m. Sunday.

—Dr. Susan Mandulitis

Jim Seghi Renovations • Jim Seghi

(248) 437-2454 • www.jimseghirenovations.com

“Don’t mess with the rest, deal with the best,” is the slogan Jim Seghi stands behind when he presents his customers with best-in-class home renovations.

Jim’s no-pressure consultation and project planning assure his customers that the price they see at the beginning of the job is the same price they see at its completion.

Jim likes to talk about Wixom, Novi, South Lyon, New Hudson, Milford, Brighton and other wonderful towns around him.

“I love to focus on local communities because word of mouth and personal references are how my business has grown so well,” Jim said. “Anybody that has any inclination to do any remodeling needs to give me a call.”

To Jim, price shouldn’t be a determining factor.

“Don’t settle for the cheapest bid when

you want quality and the assurance that you’ll be happy with the job for life,” Jim added. “I have customer referrals from people who I helped 12 years ago.”

As Jim and his wife Ellen watched their son Mauro, 10 and daughter Emilie, 5, grow, they were faced with the same challenge that many of his customers face — upgrade their existing home or buy a larger home and have their property taxes skyrocket. Jim practices what he preaches, and expanded his home.

“I help people find space where none existed before,” Jim explained. “That way they can take advantage of their existing home and not stress about moving or higher year after year taxes.”

Jim’s office hours are 8 a.m. to 5 p.m. Monday through Friday. Call for an appointment and he’ll be the guy you interface with from beginning to end.

—Dr. Michael Pridall



Submitted Photo

Jim Seghi practiced what he preached and added on to his own house.

Mayfair Realty • Abe Ayoub

(248) 486-9227 • www.soldabe.com

Ayoub has learned from the best. Therefore, he can probably be considered one of the best, too.

Ayoub is an associate broker at Mayfair Realty and serves several western suburbs as well as Lyon Township, South Lyon, Milford and Brighton.

When “best” is mentioned in Ayoub’s presence, he thinks of his three mentors.

“I have worked with Marvyn Mosher, Jay Hughes, and Bill Willis,” he said. “All of these individuals had between 30 and 50 years in the business. They were all different people and I took a little bit from all of them.”

As an associate broker, the 12-

year veteran of Mayfair Realty never faces the same routine on consecutive days — and that’s his favorite part of the job.

“You can learn something new every day,” Ayoub said.

Ayoub’s motivations and priorities in life have changed over the years.

“Some people would say their business or how much money they make is their greatest accomplishment,” he added. “My greatest accomplishment is my family. They are what drive me.”

Ayoub believes in personal contact and interacting with members of his community through work and play. He is a member of the South Lyon Chamber of Commerce, the South Lyon Kiwanis Club, and a

volunteer with the Lyon Township Fire Department. All of these important activities compliment a successful professional life.

“When people call Mayfair, they are dealing with an agent, not a company,” Ayoub said. “I work 24/7 for customers and I work very hard.”

Part of that work is doing his utmost to sell homes. Although open houses are important, Ayoub said that the personal touch needs support from the technical touch.

“I stress technology, like our Virtual Tours, and Internet presence,” he added.

For more information contact Ayoub at (248) 486-9227 or via e-mail at soldabe@comcast.net.

—Dr. John Hall

Robert Brateman, M.D. • Peter Bullach, M.D.

(248) 473-8580

www.drbrateman.com

“We take care of people when they are sick, help healthy people remain healthy and ease the suffering of those people we cannot cure. We want to make an influence on people’s lives by making their personal and professional lives more satisfying. We want to make the world a healthier place.”

—Robert Brateman, M.D.,
Family Practice Doctor

Robert Brateman and Dr. Peter Bullach have one thing in common — their professional lives revolve around the wants and needs of their patients.

That philosophy is also shared by Dr. Olga Mondrusova, who was featured in the recent “Women in the Know” supplement May 18.

The office, located on Grand River Avenue, just west of Haggerty in Novi, is state of the art as Brateman describes.

“We try to be the best doctors with the best equipment in the best office,” Brateman added.

“We have an on-site medical lab and are located close to Providence Hospital in both Novi and Livonia.”

Brateman and Bullach are both on staff at Providence.

“We work in partnership with our patients and do what is in

their best interest,” added Bullach. “We tailor each program to individual patients who need

individualized care. We do not take a cookie cutter approach to treatment.”

Both doctors have very caring approaches to their professions.

“We take care of people when they are sick, help healthy people remain healthy and ease the suffering of those people we cannot cure,” said Brateman. “We want to make an influence on people’s lives by making their personal and professional lives more satisfying. We want to make the world a healthier place.”

“We are here to provide the best possible care — not only physically but mentally and spiritually. And we are always available to our patients, whether it is being on-call or working late.”

Brateman’s care for his patients is deeply rooted in his childhood days, thanks to his family doctor.

“My family doctor was my mentor,” he added. “He took care of the whole family and he was always there for us, not just for physical problems but for other things like grief counseling.”

He graduated from Indiana University School of Medicine in 1979 and then completed a residency in family practice at Providence Hospital in 1982.

After his residency, Brateman served in the Providence Family Practice residency program as a faculty physician for six years. He founded this practice in 1989.

Bullach has been influenced by the teachings of the various doctors he has worked for.

The graduate of Albion College shows a special concern for his young patient athletes, thanks to



Peter Bullach, M.D., at left, and Robert Brateman, M.D. have very caring approaches toward their patients and believe in treating the mental and spiritual as well as the physical.

Bullach played baseball in college and baseball and football at his high school Warren DelaBelle. He is a graduate of Wayne State University’s School of Medicine.

He completed his residency at Providence Hospital and Medical Center in Southfield and joined this practice in 2002.

Brateman and Bullach never rest on their laurels, believing that life is a learning and improving process.

“We are always striving for improvement,” added Brateman. “We are always looking for ways to make the practice better.”

But in the end, the brick-and-mortar building and the equipment inside are only secondary tools for this practice.

“Our patients are the most important feature of our office,” added Brateman.

Dr. Brateman, Bullach and Mondrusova are located at 40015 Grand River Ave., Suite 100, in Novi.

The hours are 8:15 a.m. to 5 p.m. Monday through Friday. Call (248) 473-8580 for a routine or follow-up appointment.

Also visit the new Web site, www.drbrateman.com, which features interesting and educational topics that change monthly.



Abe Ayoub of Mayfair Realty believes Virtual Tours and a presence on the Internet are vital to selling property in the age of technology.

Ameritrust Realty • John H. Underwood
 (248) 431-2740 • johnunderwood@ameritrustrealty.com

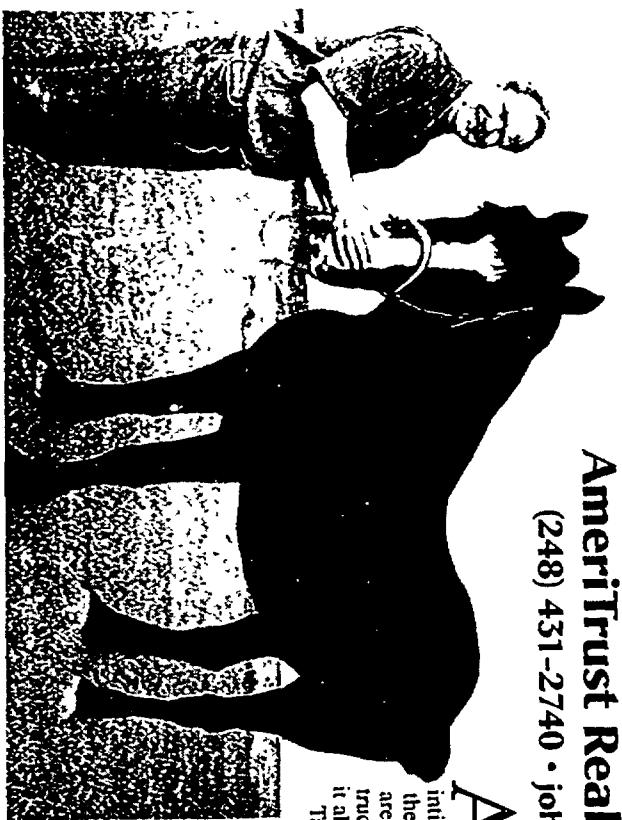

AS a resident of Brighton for the past 28 years, John Underwood is intimately familiar with one of the hottest residential growth areas in all of Michigan. By truck or by horseback, he's seen it all.

Taking that knowledge of the community, along with the skills gained in his 35-year career in sales and marketing, John is enjoying working with sellers and buyers of home and commercial properties in his new career in real estate.

When not selling real estate, John enjoys training his Percheron, Roxie.

"It's the ultimate reward," John said, "finding a perfect match between a buyer and a home." Because each real-estate situation is unique and brings its own share of challenges, John smooths the path for his clients along the way.

Ameritrust, John discovered a small, devoted company that specializes in personal service. And with his background in sales, John knows that it's often the service a customer receives that seals the deal.

"There's a high level of personal contact that takes place in any real-estate transaction. At Ameritrust, we work as a family. We can spend more time with our clients. We are a tight-knit group of highly-focused people, and we're committed to producing stress-free and error-free results in what can be an emotional experience for many clients," John said.

John and his wife Susan have lived in Livingston County since 1978. They have four children — Heather, Holly, John and Matt — and five grandchildren.

Ameritrust is located at 7015 Fieldcrest, in Brighton. Stop by and see John for your real estate needs, or talk to him about his passion for horses. He's worked with the Brighton High School Equestrian Team and helped create the Lower Michigan Horse Association.

For more information, call John at (810) 229-5060 or e-mail him at johnunderwood@ameritrustrealty.com.

Legal Counsel, P.C. • Michael Nelson
 (877) Ask-1-Now • www.AskLegalCounsel.com

attorney Michael Nelson is trying to make the legal system more accessible to ordinary people.

Often people who have a legal problem are not sure who to go to for help. Some haven't had good experiences with attorneys in the past. Others don't know where to find a good attorney whom they can trust.

Nelson and Legal Counsel, P.C., assist people in retaining the right attorney for their situation.

Nelson offers a free consultation in which clients outline their particular legal need. Nelson will identify and explain the relevant issues, as well as the steps it will take to accomplish their objective.

If Nelson is not personally retained to represent a client, he works with attorneys throughout southeast Michigan who may be able to assist the client in their particular legal matter.

"I want to provide a non-intimidating way for people to retain an attorney who has the requisite knowledge and experience in their applicable area of the law, and who is available to take on a new case at a reasonable fee," said Nelson.

Legal Counsel works with clients in an extensive variety of legal matters, including personal injury, family law, bankruptcy, estate planning, real estate, business law and litigation.

The Milford man is a veteran lawyer with over 13 years of legal experience. He holds both an MBA and a JD from the University of Detroit-Mercy. He is a well-known

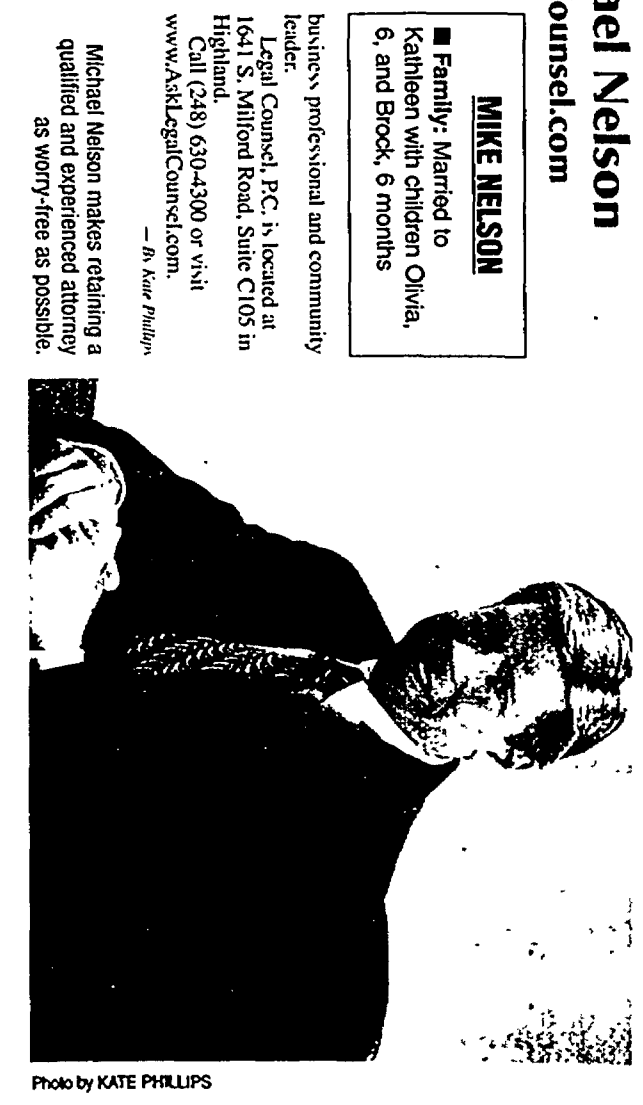

Photo by KATE PHILLIPS

MIKE NELSON
 ■ Family: Married to Kathleen with children Olivia, 6, and Brock, 6 months

business professional and community leader.

Legal Counsel, P.C. is located at 1641 S. Milford Road, Suite C105 in Highland.
 Call (248) 630-4300 or visit www.AskLegalCounsel.com.

— *By Kait Phillips*

Michael Nelson makes retaining a qualified and experienced attorney as worry-free as possible.

Town-n-Country Bikes and Killer Paintball
 Ken Powell • (248) 491-0088

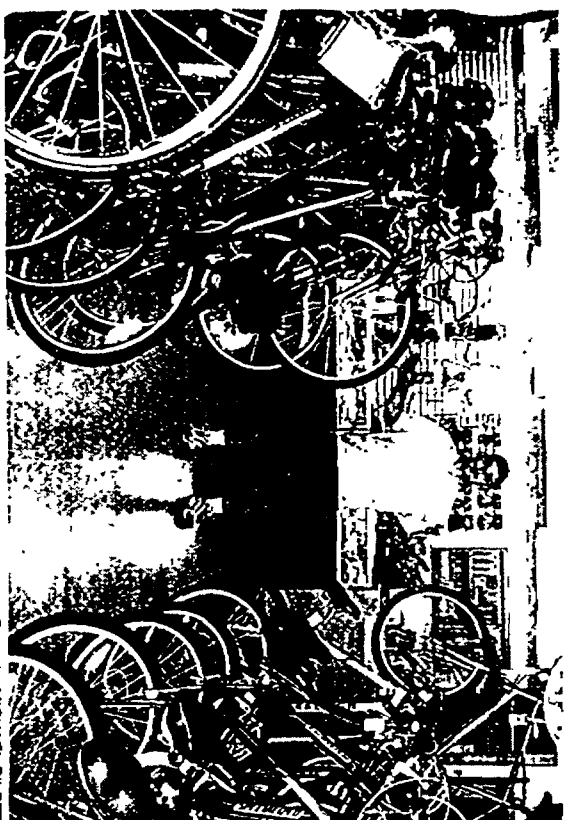

Ken Powell and his family are not new to South Lyon though his newest store is, "I'm building Town-n-Country Bikes and Killer Paintball as a family business so my kids have a place that they can use as a stepping stone toward their future," explained Ken explained with a grin.

"My son is already helping me figure out which skateboard items to stock."

Ken takes time out to coach Panther football and travel basketball. His children — Jacob, Sarah, Abigail and Jesse — all attend South Lyon schools while his wife Allison makes sure that the important things are taken care of on the home front.

For bikes and accessories, trailers, tires and tubes are available for owner installation or Ken will have one of his highly trained mechanics install and tune-up the bike at his shop.

"With the South Lyon community growing so quickly I felt there was room for a store that offered a variety of sporting products," he said as he looked around the store.

Paintball, air soft rifles, bikes, Raleigh, Specialized, Hero, Diamondback, and various safety gear and skateboards hang on the walls. The store also has the very popular Elites shoes in stock.

"My business philosophy is to be absolutely friendly and not just sell product, but sell service and educate the buyer to help them make a solid decision based on good advice," he said. "I feel I have South Lyon's support and the warmth of the community hits me each time a customer comes in the store."

Town-n-Country Bikes and Killer Paintball will be sponsoring evening bike outings for road and trail riders on Tuesdays and Thursdays this summer. Contact the store for details.

The store is open 11 a.m. to 8 p.m. Monday through Saturday and noon to 4 p.m. Sunday.

— *By Michael Philant*

Sam Rosenberg, M.D., F.A.C.S.
 (248) 735-2441 • www.srosenberg.com

frustrated when they are put on hold and told that there are no appointments available for a week or a month.

From his Novi office, Dr. Rosenberg and his staff are "very accommodating" to new and existing customers.

"I surprise answering the phone a lot," he added.

"If the phone is ringing and I'm there, why wouldn't I answer it?"

Dr. Rosenberg is chief of urology at Huron Valley-Sinai Hospital and affiliated with Providence Hospital.

Dr. Sam Rosenberg

"We are in the business of taking care of patients. And same day appointments are available."

— *Dr. Sam Rosenberg*
 Urologist

Perfect Floors • Ron Williams
 (248) 437-2838

Ron Williams brings tradition and experience of carpet, area rugs, laminate, wood floors and vinyl floors to South Lyon from Rochester where he and his brothers opened the first Perfect Floors back in 1994.

Working with hardwood and other floor coverings seems like a natural transition from his original career in the bowling alley business.

The service that distinguishes Perfect Floors from other stores is, in Ron's words, "selling the right products at a price and service which makes them very happy."

"Floor covering is usually done every seven to 10 years. Consumers should educate themselves so they will be satisfied," he advised.

Ron added that the key differentiator for his store is quality of service.

"Our quality of service and follow through after the job is complete," makes the store the best in the industry.

Ron said he is content only after satisfying his

RON WILLIAMS
 ■ Family: Married to Carolyn for 26 years, with children Ronnie, Steven and Caitlin
 ■ Favorite Movies: "Rocky" and "Austin Powers"
 ■ Hobbies: Boating, golf and bowling

customers from start to finish.

Stop by Perfect Floors, and check out their guaranteed lowest prices.

Perfect Floors is located at 21946 Pontiac Trail in South Lyon. The store is open 9 a.m. to 8 p.m. Monday, Wednesday and Friday, 9 a.m. to 6 p.m. Tuesday and Thursday, and 9 a.m. to 5 p.m. Saturday.

— *By Michael Philant*



Photo by JOHN HALL

Dr. Sam Rosenberg specializes in urological disorders from his office in Novi and as chief of urology at Huron Valley-Sinai Hospital. He is also affiliated with Providence Hospital.

of people suffering from urinary urge incontinence.

Dr. Rosenberg and his staff pay special attention to customer care and do so with a smile. Each member is trained in urological procedures.

In return for their care, patients have often brought in cakes and cookies to show their appreciation.

"When a patient comes in to a doctor's office, the last thing they want to see is someone with a grim face acting like he or she is doing them a favor," he said.

"We are in the business of taking care of patients. And same day appointments are available."

Dr. Rosenberg's office is located at 41935 W. Twelve Mile Road, Suite 308, in Novi. Contact him today.

— *By John R. Hall*

Meet the gentlemen who help bring your local paper to you

LIVINGSTON COUNTY DAILY

PRESS ARGUS

323 E. Grand River Ave., Howell
202 W. Main St., Brighton
(517) 548-2000
www.livingstondaily.com



Chris Behman
Reporter
cbehman@gannett.com



Gillis Benedict
Photographer
gbenedict@gannett.com



Lou Glubzinski
Sales Consultant
lglubzinski@gannett.com



Kris Karol
Reporter
kkarol@gannett.com



Patrick McClanahan
Sales Consultant
pmcclanahan@gannett.com



Mike Malott
News Editor
mmalott@gannett.com



Lon Meed
Reporter
lmeed@gannett.com



Dan Meisler
Reporter
dmeisler@gannett.com



Buddy Moorehouse
Metro Editor
bmoorehouse@gannett.com



Chris Nagy
Reporter
cnagy@gannett.com



Bob Pen
Sales Consultant
bpen@gannett.com



Tim Robinson
Sports Editor
trobinson@gannett.com



Rick Shepich
Sports Reporter
rshepich@gannett.com



Matt Smith
Copy Editor
mattsmith@gannett.com



Dan Strawser
Sports Reporter
dstrawser@gannett.com



Jim Totten
Reporter
jtotten@gannett.com



John Utter
Sales Manager
jutter@gannett.com



Al Ward
Photographer
award@gannett.com



Larry Weston
Sales Consultant
lweston@gannett.com



Richard Ramhoff
President & Publisher
(517) 552-2809
rramhoff@gannett.com



Rich Perberg
Executive Editor
(517) 552-2810
rperberg@gannett.com

South Lyon Herald

101 N. Lafayette St.
South Lyon
(248) 437-2011



Sam Black
Editor
sblack@gannett.com



Jim Mitchell
Reporter
jmitchell@gannett.com



Dan Trudeau
Reporter
dt Trudeau@gannett.com

Milford Times

405 N. Main St.
Milford
(248) 685-1507



Phil Allimen
Editor
pallimen@gannett.com



John Mueller
Sports Reporter
jmueller@gannett.com

NOVI NEWS Northville Record

104 W. Main St., Northville
(248) 349-1700



David Aguilar
Northville Record Editor
daguilar@gannett.com

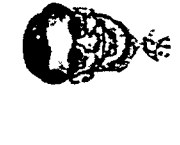

Matt Doran
Reporter
mdoran@gannett.com



Ed Fleming
Sales Consultant
efleming@gannett.com



Billy Fraser
Ad Designer
bfraser@gannett.com



John Helder
Photographer
jholder@gannett.com



Cal Stone
Novi News Editor
cstone@gannett.com

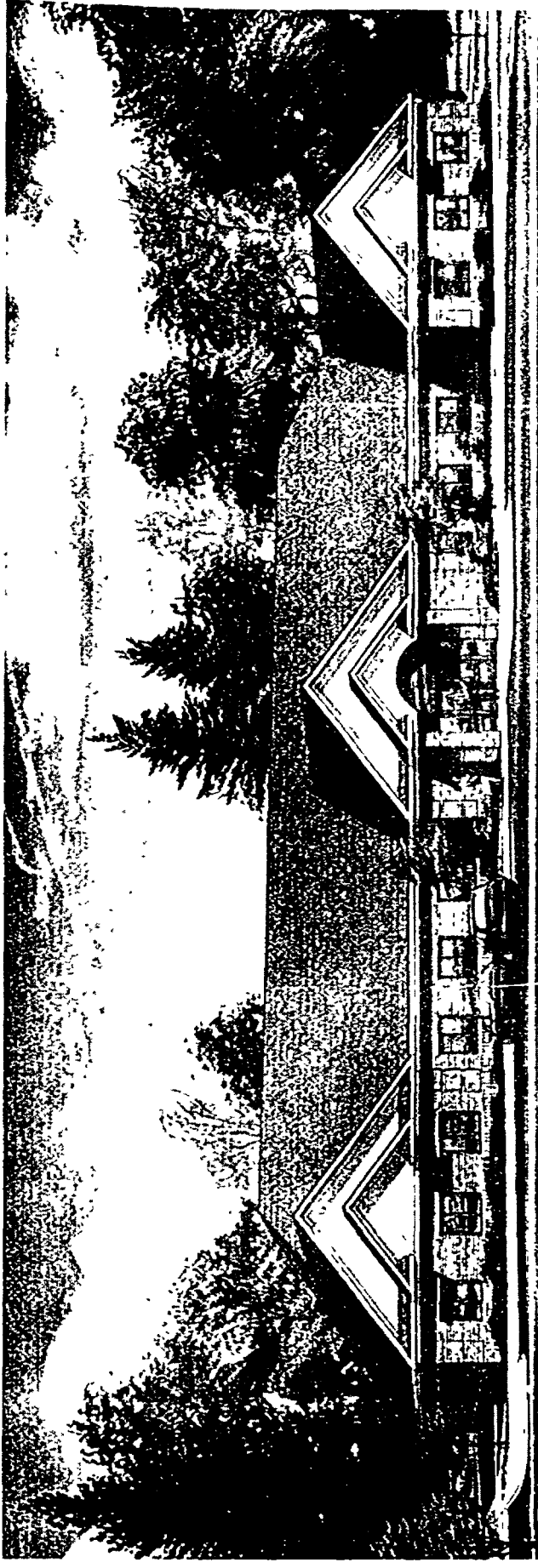

Submitted Photo

Specialists in Orthopedic Surgery make it easy for patients to get immediate care with this new location in Hartland Township. They also care for patients in their Commerce Township location.

Specialists in Orthopedic Surgery

(248) 937-4947 Commerce Township • (810) 991-3300 Hartland Township • www.weixbones.net

Earning a reputation that spans the globe, Dr. Brandt serves as Vice President and Medical Director of Orphan Medical Network International, a charitable organization devoted to providing medical treatment, education, and food for orphaned children. He travels to Zambia several times a year to provide medical care to children orphaned by AIDS.

"At first I took this on as a challenge, but once I went to Zambia it was in my blood. It's a desire to do something to make a difference in the world," says Dr. Brandt.

"We want to take care of our kids. Our goal is to make sure they get the best sports physicals possible — so that they can stay healthy."

— Dr. E. Patrick Mitchell,
Specialist in Orthopedic Surgery
Chief of Orthopedic Surgery
Huron Valley Hospital

Specialists in Orthopedic Surgery, an orthopedic practice that specializes in orthopedic medicine, sports medicine, hand surgery, arthritis surgery, spine surgery, arthroscopic surgery, and trauma surgery, just opened a second office on Highland Road in Hartland Township in addition to its Commerce Township center located at the Regional Specialty Center at Huron Valley-Sinair Hospital.

"Our locations make it very convenient for our patients to get to us," says Dr. Roland J. Brandt, D.O. "We can see patients immediately if they are hospitalized."

The practice's three physicians are: Dr. E. Patrick Mitchell, Dr. Phillip T. Schmitt, and Dr. Roland J. Brandt. All highly experienced orthopedic physicians and surgeons, the team solves complex orthopedic problems — from broken wrists to sprained ankles, to damaged knees to arthritic hips.

"We are constantly trying to do new things to make our surgical treatments better," says Dr. Mitchell, Chief of Orthopedic Surgery at Huron Valley-Sinair Hospital.

This month, Dr. Schmitt will be performing the Birmingham Hip Resurfacing surgical procedure, an innovative bone conserving alternative to total hip replacement surgery commonly used in patients who have severe damage due to degenerative joint diseases like osteoarthritis, rheumatoid arthritis, and dysplasia.

Schmitt mastered the technique during specialized training earlier this year in Birmingham, England and is one of only 32 physicians in the country trained in the procedure.

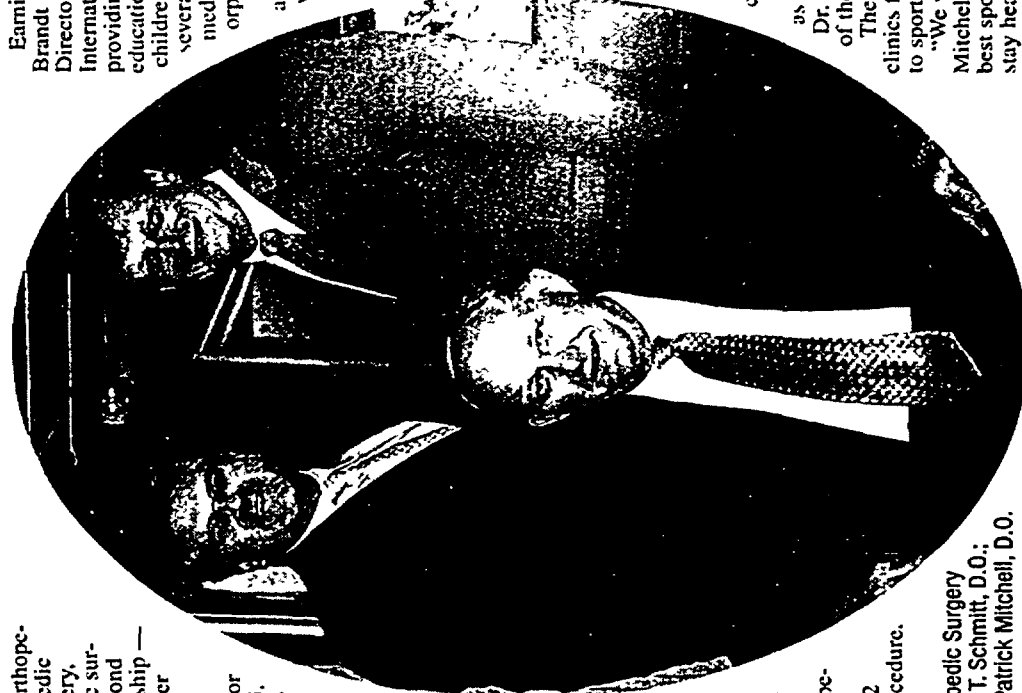

The doctors of Specialists in Orthopedic Surgery are, from left, Phillip T. Schmitt, D.O.; Roland J. Brandt, D.O.; and E. Patrick Mitchell, D.O.

as team physicians," said Dr. Schmitt. "We are there on the field as part of the team."

The practice also sponsors sports physical clinics for all teams. Fees generated are donated to sports programs.

"We want to take care of our kids," said Dr. Mitchell. "Our goal is to make sure they get the best sports physicals possible — so that they can stay healthy."



Photo by JOHN HALL
Brian Bak offers a lot of floral design choices and products for his customers in the South Lyon area.

Bakman Florist of South Lyon, Inc.

Brian Bak
(248) 437-4168

www.fhd.com/bakmanflorist

Twenty-six years is a long time to be in business — and to remain a solid business in the local community. That's true of Brian Bak and his business, Bakman Florist of South Lyon, Inc. Bak is proof that quality customer service and quality products add up to business longevity. But rather than take the credit for his success, Bak prefers to deflect accolades to his staff.

"We've always been fortunate to have a great crew," he said. "We've had very little turnover. Even when someone has had a baby, she has returned to work here."

He said that customers like seeing the same faces all of the time and will usually ask if they haven't seen an employee in a while. Even the extra help Bak brings on during the holidays keep coming back to work each season.

The three main designers at Bakman Florist include Bak, Diane Craig, and Teresa Lavigne. Bak said that all three keep up with the latest design techniques by regularly attending floral conventions.

"The three of us combined have 70 years of experience," he noted. "We are all unique and complement each other's individual expertise."

Bak said that his staff goes the extra mile to give customers that "extra touch." That includes maintaining a good rapport with other area florists if Bakman doesn't have exactly what the customer needs.

He is especially proud of the bridal packages that his staff designs.

"We make the bride's dreams come to life," he said. Bakman Florist is open 9 a.m. to 6 p.m. Monday through Friday and 9 a.m. to 4 p.m. Saturday. During holidays the florist on 22880 Pontiac Trail, is open from 10 a.m. to 2 p.m.

—By John R. Hall



Huron Valley State Bank

Dave Blosssey
(248) 684-9626

area's first community bank is coming up on their one-year anniversary. President and CEO Dave Blosssey said they've grown beyond their projected opening goals. A simple theme guides them: "Customer Focused and Community Based."

From any Main Street business to real estate development, Huron Valley State Bank stands ready to help. Since opening for business last August, they've been helping residents and businesses of Milford, Commerce, White Lake, Hartland and Highland.

Blosssey said small businesses passed over for loans by larger banks would find Huron Valley State Bank more willing to help them out.

With 45 percent of their bank stock sold to various people throughout the area, Huron Valley State Bank, at 525 N. Main St., Suite 260, Milford, is committed to doing their part to help the area thrive.

through, a wide range of banking services, a committed focus on small businesses, and community involvement.

Blosssey has been in banking 25 years. He earned a Masters of Business Administration from Central Michigan University, and prior to that attended

Michigan State University for undergrad studies. He is excited about having an opportunity to open a bank and see it grow from the ground up. In fact, the past year has been successful enough that a second Huron Valley State Bank branch, a stand-alone structure with drive-through convenience, in the south end of Milford, should open the 1st quarter of 2007.

"We're equally excited about our staff being involved in many organizations in this area. From The Highland Commerce Development Authority, The Chamber of Commerce, The Rotary Club, to coaching Little League baseball. Our desire is to be as active as we can in the community," Blosssey said. "Our involvement also includes donations."

The bank's Vice President-Louis, Patrick Burnett, is part of the bank's six-person staff interested and excited about creating something new in the community, according to Blosssey.

"People get into banking because they like interacting with others," he said. "Milford has a strong sense of community, and when people see someone getting involved there will be positive results. We want people to think of us as a bank involved in this community."

—By Nathan Merwin

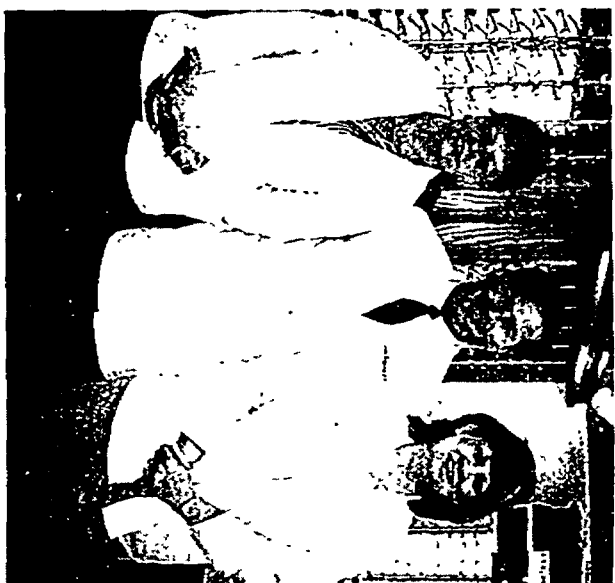

Photo by MICHAEL PILOTTI

Eager to serve clients at Bifano Family Eye Care are, from left, Nora, Dr. Chris Bifano and Karen. The practice is conveniently located in downtown South Lyon.

Bifano Family Eye Care Christopher Bifano, O.D.

(248) 446-1146

Patients visiting Bifano Family Eye Care in South Lyon get a good feeling from the moment they enter to the time they leave the familiar business, located just north of Lake Street.

That's because Christopher Bifano, O.D. and his staff provide personal service in a friendly, comfortable atmosphere. That isn't always the norm in other similar businesses.

"The doctors and staff are what set us apart from others," Dr. Bifano said. "It is a family tradition that we carry on including many services we offer."

Those services include eye exams, contact lenses, eye-glasses, eye disease treatments and a doctor on call 24 hours a day. Dr. Bifano prides himself on keeping current with all of the latest technology in eye exams and treatments. Bifano Family Eye Care offers refractive surgery in partner with the TLC Laser Eye Centers.

Great products and brand names are not the main reasons that patients keep coming back to this business that occupies its current location since 1998. It is the service.

"Patients feel comfortable here," Dr. Bifano added. That comfort level comes from a family tradition that has continued to grow in the Bifano family. Dr. Bifano comes from a family of optometrists that includes his sister and his father who practiced in Dearborn for many years. Dr. Bifano also operates a second office in Dearborn Heights.

Dr. Bifano is a 1991 graduate of the Ferris State College of Optometry and has been in business for 15 years. He lives in South Lyon.

The Bifano Family Eye Care staff includes two doctors and three opticians. Doctors are available Monday, Tuesday, Thursday and Saturday. The office is located at 317 N. Lafayette St., in South Lyon.

Office hours are 9 a.m. to 5:30 p.m. Monday, Tuesday, Wednesday and Friday; 9 a.m. to 7:30 p.m. on Thursday; and 9 a.m. to 2 p.m. Saturday.

—By Michael Pilotti

Attorney at Law • Philipp J. Weipert • (248) 486-1100

Philipp Weipert says the law is always changing, but people keep doing the same old things.

As a South Lyon attorney since 1989, Weipert has seen a lot of things change around him. The population has grown, the landscape has changed, and the law has grown more complex.

He has a book listing the name of every licensed lawyer throughout the state. There are 35,000 in Michigan. South Lyon has about 20.

"People still need lawyers. That hasn't changed," he said. "My grandfather was a country lawyer, and I count him as a mentor of mine," Weipert said. "I do what I can to help people. It's what I love doing."

The courthouses in Novi, Pontiac, Detroit, Howell, and even Lapeer are places he has gotten to know. Clients and cases, mostly civil, take up his daytime hours. He stays on top of changing laws by per-

sonally attending seminars, and others available on-line over the Internet. He updates his law books annually, too.

Weipert's community involvement makes a lengthy list: Kiwanis Club, Chairperson of the Zoning Board of Appeals, Historical Commission, and many others.

Last month he received The Paul Baker Citizen of the Year Award for his on-going volunteer efforts throughout the community. But what he's done as a volunteer only points to his professional effort.

"My greatest accomplishment is having a successful practice in town," Weipert said. Even though he calls himself a small-town lawyer, Weipert offered simple advice even big-city attorneys would agree with.

"Lawyers can't undo scrambled eggs," Weipert said with a woe-filled grin, referring to clients attempting to practice law on their own, or act as their own lawyer. "Don't try to do it yourself," he advises.

PHILIPP J. WEIPERT
■ Dream vehicle: A Jag
■ Hobbies: Biking, fishing, golfing, target shooting, woodworking, photography, and a few others

enthusiastic clients. The legal services he specializes in cover: Elder law, will/probate, living trusts & estates, real estate, personal injury, traffic offenses, automobile no-fault claims, divorce and custody, and family law.

"Spending as much time as I can with each client is the key to what I do," Weipert explained. "I try to help them as much as I can."

Weipert's office is located at 415 S. Lafayette, Suite 100. Call (248) 486-1100. —By Nathan Merwin

Bistro 127 • Don Waldemeyer (248) 921-4488 • www.bistro127.com

Move over Mike Illich and make way for partners Don Waldemeyer and Mark Koffey. South Lyon has the good fortune of having caring visionaries like Don and Mark in town.

Currently Don and Mark are renovating the old blacksmith's building across from Bistro 127 with the goal of maintaining its historic charm and structure while providing functionality and ample space. They plan to open a new Italian family restaurant, catering facilities, and the Kurnon Center, which occupied a portion of the building before renovations began. The men are working tirelessly to open the new restaurant by October.

If anyone can pull off this mini Foxtown plan, it's Don and Mark. They have the experience of managing Chicago hotels, degrees in culinary arts and business. They have worked with other local restaurateurs and have consulted with the likes of master chef Jeff Fugler on a project that has helped lay the foundation for the theater renovations next door.

Before you step into Bistro 127 you can tell Don and Mark are thinking about the community and their patrons. Signs decorate their windows heralding events and charities around town.

The design and style of the original architecture of their buildings is preserved and enhanced to reflect the small town charm and its historic beginnings. The blend of progress with compas-

■ Age: 39
■ Family: Two children: Lauren, 8, and Michael, 10
■ Hobbies: Softball, golf

■ Dream Vehicle: '14 like to get back the 1969 Fally Sport Camaro I had to sell before going overseas with the Air Force.
■ Hobbies: Golf — he played on his high-school team and stayed with it.

■ DREAM BLOSSSEY
Dave Blosssey has been in banking 25 years. He earned a Masters of Business Administration from Central Michigan University, and prior to that attended Michigan State University for undergrad studies. He is excited about having an opportunity to open a bank and see it grow from the ground up. In fact, the past year has been successful enough that a second Huron Valley State Bank branch, a stand-alone structure with drive-through convenience, in the south end of Milford, should open the 1st quarter of 2007.

"We're equally excited about our staff being involved in many organizations in this area. From The Highland Commerce Development Authority, The Chamber of Commerce, The Rotary Club, to coaching Little League baseball. Our desire is to be as active as we can in the community," Blosssey said. "Our involvement also includes donations."

The bank's six-person staff interested and excited about creating something new in the community, according to Blosssey.

"People get into banking because they like interacting with others," he said. "Milford has a strong sense of community, and when people see someone getting involved there will be positive results. We want people to think of us as a bank involved in this community."

—By Nathan Merwin



Photo by NATHAN MERWIN

South Lyon attorney Phillip J. Weipert opened his practice in 1989. He has been living in town since 1988.



Photo by HAL GOULD

Don Waldemeyer, co-owner and chef at Bistro 127, shows off a few of the 85 different varieties of wine available at the South Lyon restaurant.

of until they return. Bistro 127's wine steward, Susan Lalonde, can be contacted at (248) 613-6845 for additional information.

Dinner and Theater
Anne Levy is in charge of putting together a fantastic line-up of first class shows that will feature extremely talented artists, including the Phoenix Players. Dinner and theater packages are available for making memorable nights and wonderful gifts. Visit www.southlyonbistro.com for information.

Catered from Bistro — Laura Livingston has charge of Catered from Bistro, as a personal event planner. Her mission is to offer full-service catering amenities for any private or corporate event imaginable. Call Laura at (810) 923-4422. It's obvious one doesn't have to travel far to find first-class dining, fabulous wines, and safe

■ Family: Married to Debora, with children Donny, 10, and Katie, 4
Catered from Bistro takes care of every detail.



Submitted Photo

Catered from Bistro takes care of every detail.

■ Family: Married to Debora, with children Donny, 10, and Katie, 4
Catered from Bistro takes care of every detail.

■ Family: Married to Debora, with children Donny, 10, and Katie, 4
Catered from Bistro takes care of every detail.

■ Family: Married to Debora, with children Donny, 10, and Katie, 4
Catered from Bistro takes care of every detail.

■ Family: Married to Debora, with children Donny, 10, and Katie, 4
Catered from Bistro takes care of every detail.

■ Family: Married to Debora, with children Donny, 10, and Katie, 4
Catered from Bistro takes care of every detail.

■ Family: Married to Debora, with children Donny, 10, and Katie, 4
Catered from Bistro takes care of every detail.

VIEW
OVER 30,000
HOMES!



HOMETOWN*life.com*

WEEKLY REAL ESTATE

West

OBSERVER & ECCENTRIC • MIRROR • HOMETOWN WEEKLIES

Thursday, June 29, 2006



Cover home offered by Ivanhoe-Huntley. See their ad inside for more information on this home and others.

INSIDE



Tips to help 'babyproof' your home ... 4 'National Homeownership Month' ... 6



Hunter Homes

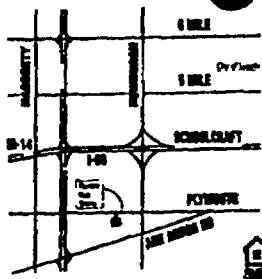

OVERLOOKING THE LAKE & PARK in Livonia

NEW SINGLE FAMILY HOME
Colonials - Ranches - Capes
1,800 - 2,500 sq. ft.



734-542-
www.hunterhomes.com



BELLEVEILLE \$460,000
4 BR, 4 1/2 BA Home with Hdwd Flrs. Gourmet Kit w/ Cherry Oak Cabs, FP, & Granite Counters & Island. 3 FP's Including One in Master Bath & Elegant 1st Flr BR. 9 foot Ceilings w/ Crown Molding Throughout.
MLS# 2609425 248-347-3050



BRIGHTON \$399,900
Serenity on 5 acres! 3 BR, 3 BA ranch w/master chef's KT hand-carved fireplace in GR, walkout basement w/ bath, huge deck, extra garage in LL and more!
MLS# 26098448 248-437-4500



CANTON \$362,000
Sharp, clean & neutral 4BR, 2.1BA Col on lg lot deep in sub Grmt kit-nk w/island Formal LR & DR Spac FR w/custom FP & mantel Mstr w/vaulted c/g & fash ba w/jetted tub. New carpet in many rms. Part Fin LL.
MLS# 26094798 734-453-6800



CANTON \$360,000
Den w/French doors, formal DR w/bay wind, vaulted Family Rm w/gas trpl, formal Living Rm, gourmet kitchen w/granite, mstr ste w/WIC & glamour bath, side entry garage.
MLS# 26091797 734-453-6800



CANTON \$350,000
2 Story Beauty On Prem Wooded Lot W/Priv & Seclusion. Foyer w/hdwd Fir. Form LR, Kit W/snack Bar, Eat in Nook, FR W/vaulted Ceiling FP, Mstr Ste W/Glam Mstr BA W/sep Whirl Tub WIC, 2 Car Gar & Trex Deck!
MLS# 26092049 248-347-3050

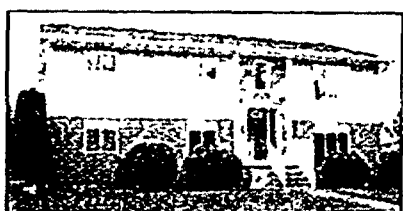

CANTON \$279,900
5 BR 3 BA Home Feels Like New CONSTRUCTION! KIT w/Granite c-tops, island Maple cabs stainless DW All BA S w/granite c-tops MBR ste w/WIC & lg BA w sep shower jetted tub & dbl sinks & 2nd flr laund
MLS# 26097582 248-347-3050

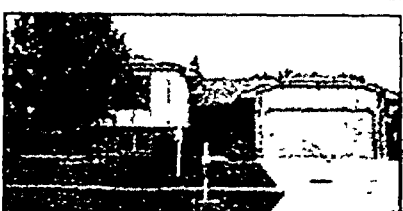

CANTON \$250,000
4 BR Quad w/a Kit W/ceramic Tile & Cust Oak Cabs Bkfst Area For LR w/Bay Window & For DR W/ wd Flrs & Drwl To Prof Lndscpd Yard FP & Wet Bar In FR Fin Bsm't w rec Rm, Laund & Plenty Of Storage!
MLS# 26096964 248-347-3050



CANTON \$246,500
3 BR 2.1 bath Colonial on a low traffic court setting. Spac kit-nook w/plenty of cbnt-entrop space & new sink (all appls included) Open-airy FR w/vaulted c/g & 8 ft doorwall Formal DR Beautiful finished bsmt
MLS# 26101607 734-453-6800



CANTON \$215,000
Form LR W/Crown Molding Bow Window, French Drs To FR w/ Vault Cing Skylights, Gas FP Kit W/gas cooktop cus Cabs w/glass Uppers, DR w/trey Cing Recess Lgts BA w/dble Sinks & Gardens/Andscop!
MLS# 26100567 248-347-3050



COMMERCE \$163,000
Sharp updated ranch with all sports take access New roof, septic field, vinyl siding and paint Remodeled kitchen and bath Possible 4th bedroom in basement
MLS# 26094348 248-437-4500



DEARBORN HEIGHTS \$159,900
3 Bedroom 2 Bath Featuring Lg Eat In Kit w/refaced Cabs, Updates Include Electrical Exterior Doors Roof Gutters Downspouts, Newer Furnace/air h20, & More Paints! Fin Bsm't 2 Car Gar 1 Yr Home Warr!
MLS# 26093567 248-347-3050



DEARBORN HEIGHTS \$159,900
Fin Bsm't W/lav Kit W/maple Cabs, New Carpet & Paint T/D 1.5 Car Gar, Maint Free Ext Mstr Ste W/dtl In Dressers Move-in Con Newer Flrs In DR Updated BA, New Cement Patios Front & Back New Wd Deck
MLS# 26101656 248-347-3050



DETROIT \$120,000
Great investment opportunity All appliances to remain with home Pre approval & EMD to be submitted with all offers All data is estimated Selling agent to verify all measurements Priced to sell!
MLS# 26101159 734-453-6800



DETROIT \$89,900
Completely remodeled inside!! Don't miss this charming bungalow w/updates galore! Refinshed HDWD flrs T/O, new kit w/ceramic tiles & wood cabs freshly tiled full bath formal LR w/ cov ceilings
MLS# 26096779 734-453-6800



DETROIT \$61,000
Great investment opportunity All appliances to remain with home Pre approval & EMD to be submitted with all offers All data is estimated Selling agent to verify all measurements Priced to sell!
MLS# 26101113 734-453-6800



FARMINGTON HILLS \$450,000
Condo w/unfin w/o w/2-sided fp GR w/vaulted ceiling w/marble FP & butler's pantry formal DR w/vaulted ceiling white cabs in kit new dw & Sub Zero refing 1st flr mstr & ceramic tile in foyer & kit
MLS# 26087246 248-347-3050



FARMINGTON HILLS \$329,900
Sitting pretty! the 2004 improvements make this home ready for new owners New windows & maintenance free vinyl trim compliment the brick exterior New wood floors & backsplash 3 car side entry car & lg lot
MLS# 26094200 734-453-6800



FARMINGTON HILLS \$239,900
Priced well below market this raised ranch (3 steps up to bdrms), wooded private lot, C/A covered patio, alarm 1st floor laundry, 2.5 car garage, newer HW/H, 2 way fireplace between living/family rooms
MLS# 26093425 248-347-3050



FARMINGTON HILLS \$239,000
Spectacular Springbrook Sub Newer Neutral Carpet, Lots Of Cabinet/Counter Space In Kit Mstr Bed w Full Ba Form DR Part Fin Bsm't/ Bonus Rm For Office/ Play Rm Full Bath In Bsm't Inviting Frt Porch
MLS# 26081656 734-591-0333



FARMINGTON HILLS \$129,900
Lovely 62+ quiet com Feat incl 2 BR's, 2 Ba, Kit w/ oak cab DR, LR w/cath cell & drwl to Fla Rm 1st flr laundry, newer furn crpt & paint Clean well maintained All app's incl Immed occ
MLS# 26047881 734-453-6800



GENOA \$239,900
Rustic and charm on gorgeous private setting of 1.9 acres! 3 BR 2 BA Cape Cod has warm wood floors quant kit, spacious DR unfinished walkout and more!
MLS# 26085274 248-437-4500



GREEN OAK \$324,000
Protected woodlands offer privacy! 3 BR, 3 BA Colonial w/huge tiled deck Sun filled KT 1st flr laundry GR w/cath ceiling Spacious MBR & more!
MLS# 26097825 248-437-4500



HIGHLAND PARK \$53,000
Great investment opportunity All appliances to remain with home Pre approval & EMD to be submitted with all offers All data is estimated Selling agent to verify all measurements Priced to sell!
MLS# 26101233 734-453-6800



INKSTER \$99,900
This Comfortable Home Has A Private Back Yard 2 Sheds w/Patio and Deck In Front Nice Door Wall Off Kit and A Partially Finished Basement, w/ Possible Bedroom Great Starter Home With A Home Warranty
MLS# 26096667 248-347-3050

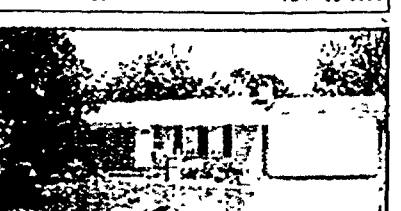

LIVONIA \$219,900
The Best Priced Home In NW Livonia Completely Updated Brand New LgKit w/Cherry Cabinets, New Roof, New Windows, New Furnace, Elec HW/H, New Entry Doors & Landscaping Lg LR With Natural FP
MLS# 26096130 248-347-3050



LYONS \$460,000
3.5 bath, 4bed In Golf Course Community! 2-story Foyer staircase New Granite Island In & new maple Fl In Kit Fin LL w/o W/gr office & Full Bath 3-car Side Entry Gar 2-story Lr & Dr, Fr W/FP Deck & More!
MLS# 26061384 248-347-3050



LYONS \$252,900
Enjoy private cul-de sac site boasting lavish gardens complete w/deck side waterfalls Home offers wrap around porch Update incl cer flrs crpt kit 3 Dr fl (w/o) Fin LL w possible 4th BR Home warranty
MLS# 26102259 734-453-6800



MARION \$240,000
Vaulted GR w/gas FP, open kit w/island nook w/view to spectacular wooded yard 1st flr indry mstr ste w/ vaulted ceiling WIC & glamour BA prof finished lower level w/daylight wind & F.N.B.A.
MLS# 26089179 734-453-6800



MELWINDALE \$110,000
Updated Ranch w/open fir plan HDWD flrs T/O newer A/C windows & plumb freshly painted T/D Glamour bath w ceramic LL w/kitchenette & updated full bath w ceramic Fenced yard backs to park
MLS# 26101053 734-453-6800

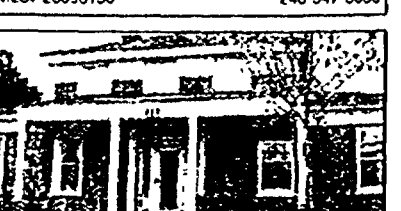

MILFORD \$345,000
Beautifully Restored 1849 Greek Revival home Exten Woodwork & Flng Retains Its Original Charm Fp In 4th Bed cozy & Charming Office Extra Lg 2.5 Car Gar 24" Thick Walls For More Eff Heat/cooling
MLS# 26093923 248-347-3050

COMMERCE/WEST BLOOMFIELD • 2685 Union Lake Rd.
LIVONIA • 36650 Five Mile Road, Suite 101
NORTHVILLE • 41860 Six Mile Road
PLYMOUTH • 218 South Main Street

SOUTH LYON • 12568 Ten Mile Road

Real Estate Classes & Training. 888-414-8330

Or visit our web site, and sign up online.

COLDWELL BANKER**Schweitzer Real Estate**
Residential Real Estate

An Independently Owned and Operated Member of Coldwell Banker Residential Affiliates, Inc.

#1 Coldwell Banker in Michigan

If it's on the market, it's on our website...www.cbschweitzer.com

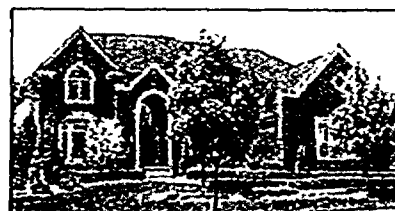
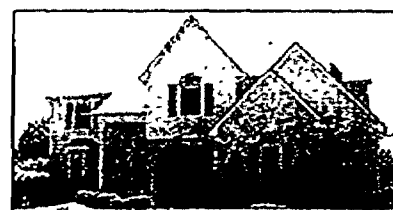
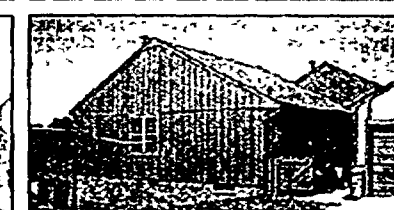
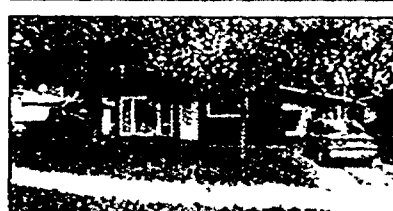
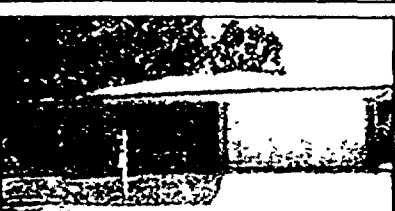
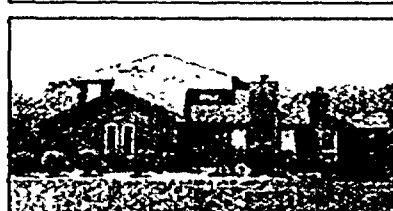
**NORTHFIELD** \$226,900
Beautiful move in condition ranch with 3 bedrooms and 2 baths. Cathedral ceilings. Covered porch and stone patio. Must see. MLS# 26100314 248-437-4500**NORTHVILLE** \$1,275,000
Lakefront Living! 2 Story Foyer Kit w/granite DR w/buders Pantry, Solid Doors T/O 2 Story FR w/Tray Ceiling. Master suite w/ sitting Area, Fr Fin W/O W/Full Granite Kit, in-law suite & Views Of Teal Lake From Every Window! MLS# 26065412 248-347-3050**NORTHVILLE** \$1,200,000
Marble Foyer w/ Staircase, Lib W built in Bookshelves, DR w/Tray Ceiling Conservatory w/Deck, Kit w/Granite, sub-zero fridge, Sun rm w/wooded Ceiling/skylights, mstr ste w/ glamour BA, Media rm 5th BR in-law suite & in-scope! MLS# 26094102 248-347-3050**NORTHVILLE** \$590,000
Northville 2 story brick col on lg wooded lot in exclusive Waterstone Est. Spacious fr plan, FR w/corner FP, granite w/ist, Wood flooring, butlers pantry & study Form LR, DR, dual storce 1st fr Indry Day/ite bsmt. MLS# 26049996 734-453-6800**NORTHVILLE** \$450,000
On A priv Cal-de-sac Location. Clean Home w/neutral decor Beautifully Appointed Updated Kit w/ granite, SS appls, Maple Cabs Kohler Accessories. Lrg mstr Has 2 WCs. Granite to Vaulted Ceilings. Gorgeous Paver Patio. MLS# 26102901 248-347-3050**NOVI** \$1,250,000
Home On Private Cul-de-sac w/Landscaping Premium Stone elev 4 Fp's, extensive "jharra" hwd frs In DR, LR & Entire 2nd fr Handmade Cabs. Home Theatre In Study, gran'ie 2 story Foyer w/ marble, exercise rm OPI mstr ste. W.S.# 26074428 243-347-3050**NOVI** \$569,900
Waterfront living at its finest! Spectacular 3 BR, 3 1/2 BA magazine quality condo on one of the finest waterfront settings on Island Lake. Gourmet kit w/ granite countertops. Finished 3rd fr loft. Your own boat slip. MLS# 26097864 734-453-6800**NOVI** \$425,000
On large lot w/in-ground pool, mstr ste w/sitting area for nursery or exercise rm. 2-story foyer, hwd frs in foyer, half bath & kit. Bsmt w/rec rm & partial kit. 2.5 car garage, dual staircases, 3.5 baths, & new siding. MLS# 26071210 248-347-3050**NOVI** \$190,000
Golf Course Views. Foyer Open To Vaulted GR w/ Staircase. FP w/ marble Surround. 1st fr mstr w/ dual Closets & mstr BA, 2nd BR w/private BA, 1b/3rd BR. Kit w/cock top. All Kit appls Stay. Attached Garage. Pool & Clubhouse! MLS# 26104356 248-347-3050**NOVI** \$160,000
Brick Ranch! New schools! Updates incl 06 wndws & drnd, kit fr 6 panel doors to OS fresh paint, hot water newer c/a-furnace. Huge yard! All appls stay. Immediate occupancy. Motivated sellers - won't last! MLS# 26094788 734-453-6800**PINCKNEY** \$167,900
Sharp well maintained 3 BR Ranch. New paint throughout, formal finished basement, doorwall leads to privacy fenced backyard and deck. Home warranty. MLS# 26083223 248-437-4500**PLYMOUTH** \$549,900
Plymouth Commons col. 4 BR 4 1/2 BA exec home on park-like setting backs to acres of commons. Kit w/ plenty of cabinet space, newer B1 appl. Lux mstr ste w/FP & bath BA. FR w/FP. Lg BR's Prof fin LL w/Kit & N.J. ba. MLS# 26067846 734-453-6800**PLYMOUTH** \$449,900
4 BR, 2 1/2 BA Cape on private wooded ct setting. Kit w/ granite island B1 appls. hwd fr spac nook & 13x12 hearth rm w/gas FP. 1st fr master w/vaulted cng. 4th BR currently a kit. Full bsmt w/ daylight wndws. MLS# 26101007 734-453-6800**PLYMOUTH** \$367,900
Truly unique! Secluded covered front porch for your summer enjoyment, remodeled kitchen & baths, quality throughout, spacious bedrooms, two gazebos, storybook shed, finished basement with full bath. Beacon Trail Sub. MLS# 26096368 248-453-6800**REDFORD** \$124,900
Very Nice Well Kept Home With Schools & Plenty Of Shopping Nearby. This Home Offers Newer Windows, Furnace, Root, HWHT Siding, Gutters & C.A. Just Move Right Into This Cozy Home Located In The City Of Redford. MLS# 26124132 248-347-3050**ROMULUS** \$235,000
4 BR 2700 Square feet cape cod w/walkout, gourmet kit, bh hook, 1st fr laundry 1st fr mstr ste w/ glamour bath & WIC. Fin LR 13m huge bedrms w/WC covered porch over 1.2 acre fenced yard w/ pool and gazebo. MLS# 26090442 734-453-6800**SALINE** \$1,950,000
Brick ranch on 1.19 acres! Volume ceilings to, remodeled kit, 4.5 car heated gar, mahogany entrance drs to stunning foyer w/6 skylights, fin LL w/FR, game rm, rec rm, office, bath, bar. Paver walks, patio & waterfall. MLS# 26077617 248-347-3050**SCIO** \$320,000
Tremendous value in popular Hometown Village 3 BR col offers open floor plan w/ a lot of character. GR w/ gas FP, granite w/ist fr m, LR DR or office 1st fr Indry. W/O LL only fr & will be fr prior to close. MLS# 26093922 734-453-6800**SOUTH LYON** \$349,900
Brick 4 BR, 2 1/2 BA colonial backs To Woods On A Cul-de-sac Street! Hwd frs. Huge Kitchen. 2 Story FR w/FP. 1st fr Laundry Office. Library. DR w/bay Windows. daylight Extra Block bsmt! Easywa To Downtown South Lyon! MLS# 2609386 248-347-3050**SOUTH LYON** \$149,900
Lock no longer, this is the 55+ co-op you have been waiting for. Great location and fantastic view. Beautifully decorated 2 bedroom condo. Must see. MLS# 26103908 248-437-4500**WATERFORD** \$275,000
Penthouse condo w/ views of Cass Lake sunsets! GR w/FP w/ vaulted ceiling totally remodeled to balcony vaulted ceiling in mstr ste w/private bath, monthly fee includes basic cable & water. Dock facility available. MLS# 26066739 248-347-3050**WESTLAND** \$185,000
Gorgeous contemporary 3 BR Colonial Open fr plan, FR w/FP & bath cng. Kit w/ ceramic tile, spacious master ste w/vaulted cng & WIC. Fin LL w/rg rec rm, prof indsp yd w/sprinkler sys. This home is extremely clean! MLS# 26100321 734-453-6800**WESTLAND** \$131,900
Livonia Schools. Narrow Front Brick Ranch Has Newer Windows, Brand New Kitchen Cabinets and Tops. Huge 2 1/2 Car Garage and Carport. Gives Room For All Your Toys. MLS# 26094922 248-347-3050**WESTLAND** \$116,900
Cute starter home in Westland. 2 bed, 1 bath, fresh paint. Updated bath, cute kitchen and a huge garage in a fenced yard. MLS# 26075061 248-437-4500 12851427**WESTLAND** \$105,000
3 bedroom Ranch freshly painted throughout. New carpet in bedrooms, large eat in kitchen w/ newer floors, neutral decor throughout. All appliances stay. Motivated sellers offer home warranty. MLS# 26097957 734-453-6800 13032494**WHITE LAKE** \$335,000
White Lake Canal just 10 minutes by boat to the MAIN LAKE. Great open floor plan home w/ large deck for entertaining or enjoy the finished W/O LL and step out to the brick paver patio. 026086218. MLS# 26086218 Pamela Bartush 248-360-1425 Ext 204**CANTON** \$212,900
Updated Brick Ranch w/rg FR w/Nat FP & vld Ceiling. hwd frs In LR & Under Carpet In BR's. Newer str & Ref. New serv/cntrs In Kit. Main Lvl W/ hwy BA, Full BA w/dbl Sinks. Lnsdpl Yd W shed Backs To Wooded Area. 248-347-3050**HAMBURG** \$399,999
On 5+ Acres w/split a/c! Walkout To Custom Deck & Cabana That Overlook property. Walkout Bsmt. Prepped & Ready For Your Finishing Touches. drvl To brick Paver Patio. On A priv Rd. Investors welcome. Home Warranty. 248-347-3050**LIVONIA** \$152,900
Ground Floor Ranch Condo With Garage Right In Front. Private Entrance. Updated Kitchen With Newer Cabinets. Newer Neutral Carpet & paint. Huge Floors, Enclosed Patio With Storms For All Year Use. Complex Has Pool. 248-347-3050**NORTHVILLE** \$219,500
Be The First To Live In This 2005 Built Contemporary Condo w/ high ceilings, Corner FP In GR, Open Floor Plan. 1st Fl Laundry mud Rm. Balcony & GR Overlook Resort Type Pool & Pond. Home Is light, Bright & Open. 248-347-3050

01-09-450601

COMMERCE/WEST BLOOMFIELD • 2685 Union Lake Rd.

SOUTH LYON • 12568 Ten Mile Road

LIVONIA • 36650 Five Mile Road, Suite 101

NORTHVILLE • 41860 Six Mile Road

PLYMOUTH • 218 South Main Street

Real Estate Classes & Training. 888-414-8330

Or visit our web site, and sign up online.

Take look around your home to help 'babyproof' it

Babies learn quickly in their first year. For new parents, it's a pleasant surprise to see how soon they begin moving and exploring. But turn your back for a moment, and the infant who was squirming helplessly on a blanket is suddenly crawling across the room at high speeds.

Children are naturally curious. Tasting, touching and feeling are how infants and toddlers learn about the world around them. Take a moment to look at your surroundings from a youngster's point of view. Then make any necessary adjustments to babyproof your home.

Mechanical suffocation and suffocation by ingested objects cause the most home fatalities to children 0-4 years of age. Drownings and home fires also contribute to the death of young children.

SUFFOCATION AND CHOKING

■ Infants, when placed on an adult bed of any kind, can roll into the space between the wall and the mattress and suffocate. Exercise caution if sleeping in the same bed with an infant. It is possible for an infant to become wedged

between your body and the mattress and suffocate. Infants should never be placed on top of soft surfaces like sofas, large soft toys, sofa cushions, pillows, water beds or on top of blankets, quilts or comforters.

■ Babies should sleep on their backs.

■ Crib bars should be no more than $2\frac{3}{8}$ inches apart to prevent infants from getting their heads stuck between them. Cribs manufactured after 1974 must meet this and other strict safety standards.

■ The crib mattress must fit tightly so there are no gaps for an infant to fall into. Keep the crib clear of plastic sheets, pillows and large stuffed animals or toys. These can be suffocation hazards.

■ Keep toys with long strings or cords away from infants and young children. A cord can become wrapped around an infant's neck and cause strangulation. Toys with long strings, cords, loops or ribbons should never be hung in cribs or playpens. Similarly, pacifiers should never be attached to strings or ribbons around the baby's neck.

■ Place an infant or child's bed away from any windows. Check window coverings for potentially hazardous pull cords.

■ Use child safety gates at the top and bottom of all staircases and be sure they're installed correctly. Avoid accordion style safety gates with large openings that children could fit their heads through.

■ Choking is a common cause of unintentional death in children under the age of 1. Avoid all foods that could lodge in a child's throat. Some examples include popcorn, grapes, foods with pits, raisins, nuts, hard candies, raw vegetables, and small pieces of hot dogs.

■ Never let children of any age eat or suck on anything, such as hard candy, while lying down.

■ Keep floors, tables and cabinet tops



free of small objects that could be swallowed. Such objects include coins, button-sized batteries, rings, nails, tacks and broken or deflated balloons.

FALLS AND BURNS

■ A mixer faucet on the basin, tub and shower will prevent scalds. Set your hot water thermostat for 120° F. A baby's bathwater should be 100° F. Always check bathwater temperature with your wrist or elbow before putting a baby in to bathe. Don't allow children in a whirlpool, Jacuzzi or hot tub. Their bodies are more sensitive to hot water.

■ Teach youngsters that matches are tools for adults, not toys. Adults should never ignite lighters or matches in front of children. Store matches in a fire-resistant container out of the reach of youngsters.

■ Do not smoke, use matches or drink hot beverages while holding an infant. Don't leave burning cigarettes unattended.

■ Remember that radiators, heating vents, space heaters, fireplaces, stoves and hot water taps are not always hot. Children can touch them once safely and the next time receive a severe burn.

■ Keep electrical cords and wires out of the way so toddlers can't pull, trip or chew on them. Cover wall outlets with safety caps.

DROWNING

■ Never leave a child unsupervised in the bathtub. If you must leave the room for a telephone call or to answer the

door, wrap the child in a towel and take him or her with you. Don't leave a small child alone with any container of liquid, including wading pools, scrub buckets, and toilets.

■ A swimming pool drowning could also be called a "silent death" as there is rarely a splash or cry for help to alert parents to the problem. The typical drowning victim is a boy between 1 and 3 years old who is thought not to be in the pool area at the time of the incident.

■ Fence in the pool completely. Doors leading to the pool area should be self-closing and self-latching or equipped with exit alarms and should never be propped open.

■ Never take your eyes off children when they are in or near any body of water, not even for a second. Don't rely on inflatable devices, such as inner tubes, water wings, inflatable mattresses and toys or other similar objects to keep a youngster afloat. Keep toys, tricycles and other playthings away from the pool area. A toddler near the water could unexpectedly fall in.

■ All pool owners and their families are encouraged to seek training in swimming, lifesaving, first aid and cardiopulmonary resuscitation.

If it seems that there is a lot to do before that new bundle of joy comes home - you are correct. However, simple safety checks can help ensure that you and baby will have many happy and healthy years together.

For more, visit the National Safety Council online at nsc.org.



HOMETOWNLIFE.COM

Weekly Real Estate

HOW TO REACH US

Peter Neill
Vice President/General Manager
(734) 953-2252
pneill@hometownlife.com

Julie Brown
Editor
(734) 953-2111
jcbrown@hometownlife.com

Advertising Information

Observer & Eccentric
Marty Carry
(734) 953-2150
mcarry@hometownlife.com

Hometown Weeklies
Grace Perry
(248) 349-1700, ext. 120
gperry@gannett.com

Mirror Newspapers
Elaine Myers
(248) 546-4900, ext. 268
esmyers@hometownlife.com

COLDWELL BANKER**SOLD****DISCOVER THE DIFFERENCE
PROFESSIONALISM. SATISFACTION. RESULTS.**

CE0845096

View Thousands of Available Homes in Your Area

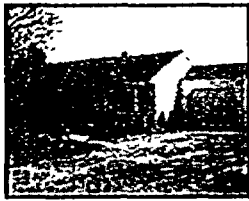
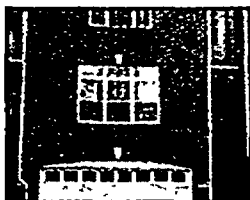
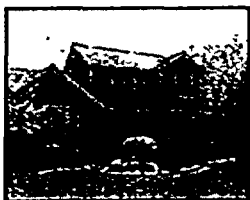
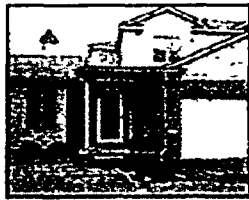
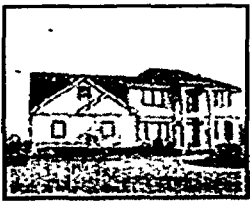
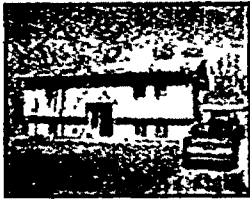
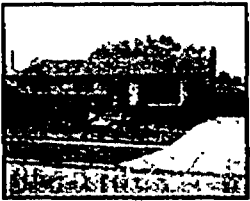
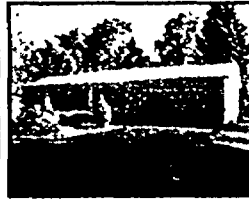
On Our Website @ www.cbpreferred.com**PREFERRED, REALTORS****COLDWELL BANKER**All Real Estate
Companies are
not the same!**COUNTRY SETTING** Doll house on a hill with a wooded double lot. Great starter or retiree home. Lots of updates including the kitchen and bath. Neutrally decorated. Appliances remain. Call for more information. (P-478PI) **\$87,000****NEWBURGH LAKES CONDO** Spacious 1st floor end unit w/neutral décor. Very clean, starter or retiree home. Lots of updates including the kitchen and bath. Neutrally decorated. Appliances included. Excellent location. (P-192AN) **\$95,500****BEAUTIFULLY UPDATED** Spacious floor plan offers 4 bd, 2.5 baths, updated vinyl siding & trim, windows, furnace, & roof. Add to this a custom Master Suite, Family Room w/frp, large patio, fenced yard, & updated Kitchen. (P-677AP) **\$209,900****SOUGHT AFTER ROSEDALE** Charming colonial on a double lot w/over 1700 square ft. of living space. Formal dining, cozy FR with a flpc, 3 BR's and 1.5 updated baths. Nicely manicured exterior with brick pavers. Really nice! (P-309AR) **\$239,900****BRAND SPANKING NEW** Bright and spacious new construction condo w/2 bd, 1.5 baths, huge kitchen, large dining area, oversized master, basement & garage. You won't find a better deal anywhere at this price. (P-726BR) **\$129,900****SPACIOUS UPDATED RANCH** 3 BR, 1 full bath recently remodeled. All new carpeting, updated paint, updated kit w/oak cabs, newer vinyl windows & 1 car gar. Maint free exterior w/stone, vinyl, & large yard. (P-945GO) **\$149,900****CANTON CHERRY HILL VILLAGE** 4 bd, 3.5 bath home loaded w/ upgrades, open floor plan, extra deep finished bsmt, cherry cabinets, & more. (P-572FI) **\$409,000****CANTON CONDO** Open floor plan offers a GR w/frpl, Master Suite w/WIC & bath, FFL, garage, & fin bsmt. Neighborhood pool, & tennis. (P-837GR) **\$196,900****GREAT LOCATION** Super Cape Cod w/striking great room, flpc, finished bsmt, 1st floor master & a patio for summer enjoyment. (C-2145A) **\$289,000****FANTASTIC CAPE COD** 4 bd, 2.5 ba located in great sub. Large Kit, updated carpet, custom blinds, & central vacuum, 1st floor Master w/Jacuzzi, 4 season room, lavish landscaping & Patio. (C-95550) **\$319,900****CANTON CENTRAL PARK** STEAL Terrific colonial w/2 story brick elevation, volume ceilings, hwd floors, open floor plan, island Kit, FFL, oversized master w/bath, & prof landscaped. (P-3965P) **\$364,900****BETTER HURRY!** This huge 4 bd colonial is a gem! Master w/bath & WIC, FR w/frpl, major updates inc paint, carpet, flooring, roof, siding, windows, A/C & furnace, & large yard. (P-767TI) **\$249,900****COMMERCIAL** Popular Huron Hills sub boasting custom features, 2 decks, oversized gar, paver walkways, premium location, 3 bd, & 2.5 baths. (P-630HU) **\$299,900****TOO COSTLY TO DUPLICATE!** Overlooking the 18th fairway & Tray Lake lies this lovely Duke model w/numerous upgrades, recessed lighting, ceramic floors, finished walkout & luxurious master. (P-313IV) **\$449,995****MOTIVATED SELLER** 3 bd ranch featuring an updated Kit, bathroom, flooring, windows, roof, finished bsmt, & seller will help w/closing costs. Bring offers! (P-314HU) **\$70,000****FARMINGTON HILLS INCREDIBLY ATTRACTIVE** Farmington Hills colonial w/ huge master, large oak kitchen, fin bsmt, 2 car garage & lovely dramatic details w/o. Call now! (C-886PE) **\$279,800****GARDEN CITY MOVE IN CONDITION** 2 bd (possibly 3 bd) ranch has been meticulously maintained & updated. New carpet, updated bath & fresh paint. (C-540CA) **\$130,000****GARDEN CITY FABULOUS RANCH** Huge corner lot, finished bsmt, updated ceramic bath, new carpet & Pergo w/o, vinyl windows, hwh, C/A, tear off roof, siding, pool, deck, cement Patio & new garage. (P-921EL) **\$199,900****GARDEN CITY AFFORDABLE** 3 bd brick ranch offers 6 panel doors, newer carpet, updated Kit floor, 2 car garage & huge backyard. Home warranty. (P-607MA) **\$149,900****GARDEN CITY PRICED BELOW MARKET** Lovely 3 bd, 2 bath ranch w/ new siding, windows, doors, picture window, partially finished bsmt, new garage & vinyl fencing. (P-224RO) **\$149,500****HOWELL MAINTAINED CONDO** Neutral décor w/many builder upgrades. Open & spacious floor plan w/cath ceilings, & kitchen w/ceramic tile & cherry cabinets. Great location! (P-654OL) **\$124,900****INKSTER CURB APPEAL PLUS!** Extremely well maintained brick ranch w/2 bd, 2 baths, finished bsmt, new furnace, ac, windows, fenced yard & appliances. (P-994GL) **\$99,900****INKSTER GREAT STARTER HOME** Nice ranch w/eat in Kitchen, hwd floors, enclosed porch, 2.5 car Garage & large backyard. Land contract available. (C-825NO) **\$84,900****LATHRUP VILLAGE IMMACULATE RANCH** 3 bd, 2 ba, bsmt, garage, freshly painted, bright kit, FR, doorwall to deck, oversized closets, 1st floor laundry. (C-215LA) **\$194,900****LIVONIA NICE HOME** Nice starter w/ plenty of possibilities. Updated include roof, furnace & hwh. Insulated garage w/220, 50x202 lot & more. (C-151AL) **\$119,900****LODI TOWNSHIP 40 ACRE COUNTRY ESTATE** Just imagine a unique architectural design w/over 5000 sq ft, 3 bd, 3 full baths, 3 flpcs, inground pool, spa, steam room, huge pole barn & more. (C-708TE) **\$1,375,000****MELVINDALE HIDDEN JEWEL** Well maintained bungalow w/ new bath, spacious master w/hwd floors, eat-in kit w/bay window, newer windows, driveway, HWH, roof, doorwall to fenced yard & huge Garage. (C-657PR) **\$114,900****NORTHVILLE YOU FOUND IT!** Gorgeous condo is beautifully decorated, end unit, new floors & fixtures, enclosed seasonal porch, appls & great location! (C-560NO) **\$127,000****YPSILANTI PERFECT FOR FIRST TIMERS** Walking distance to EMU w/ huge lot! New roof, windows, siding, gutters, hwh, glass block bsmt, new garage door opener. (C-226PR) **\$129,900****YPSILANTI INVESTMENT DUPLEX** Steps from EMU campus at the old water tower. 2 units, already rented for the semester. Newer furnaces, siding, hwh's, exterior doors & excellent parking behind house. (P-218SU) **\$199,500****CHERRY GROVE CONDO** Tons of space in this 2 bd, 2.5 bath condo w/loft for additional living. Great room w/frp & balcony, formal dining, huge eat-in kitchen, part finished bsmt w/doorwall to backyard. (P-846CH) **\$219,900****SPECTACULAR COLONIAL** Outstanding in every way. 2500+ sq ft colonial w/corrian crown molding, fabulous fashion bath, fabulous gardens & much more. (C-152EL) **\$382,500****COMPLETELY UPDATED** Nothing left to do but move in! Updated siding, roof, oak Kitchen, ceramic tile floors, bath, carpet, furnace, & C/A. Tasteful décor, 2.5 car Garage, large Deck & more. Perfect house just waiting for new owner! (C-118HE) **\$137,500****COUNTRY FEEL** Have space & convenience in this Plymouth Township ranch. 3 bedrooms, lots of updates, deck w/hot tub & located on a half acre lot. A must see! (C-850MA) **\$225,000****ONE OF A KIND** Full brick home featuring 3 car Garage, 3100 sq ft, huge Great Room, open Kitchen w/upgraded cabinets, hwd floors, all appliances stay, deluxe Master Suite, extra deep bsmt, & backs to open land & sides to stream. (C-083SH) **\$379,900****MOVE-IN CONDITION** Decorated w/designer colors t/o. Hwd floors, attached Garage w/direct access to unit. Open area upstairs could be library or study. Great Room wired for surround sound, & Patio This will not last! (C-110NE) **\$188,750****PEACEFUL SETTING & WOODED VIEW** Spotless 3 bd Livonia ranch, recent updates: driveway, porch, vinyl siding w/insulation, main sewer line & storm doors, spacious oak kitchen & breakfast room & 2 car detached garage. (C-201OR) **\$150,000****SPACIOUS RANCH** This 3 bd, 2 bath ranch has all the bells & whistles. Formal Living & Dining Rooms, Family Room, fenced yard, 2 car Garage, & all appliances stay. 1 yr home warranty. (C-535WH) **\$187,000****CUSTOM HOME** Impressive approach to this 1998 custom built home. Many high quality amenities, 4 bd, 3.5 baths, home gym, 3 car garage, finished lower level, enclosed Deck, pole barn, & situated on 5 1/2 acres. South Lyon schools. (P-710PO) **\$649,900****LIVONIA SCHOOLS** 3 Bd ranch featuring 2 car Garage, 32x12 Deck, updated roof, updated Bath & electric. Large eat-in Kitchen w/loads of oak cabinets, all appls + washer & dryer included. Fenced yard, immediate Occupancy. (C-262CA) **\$137,000****DUPLEX OR SINGLE FAMILY HOME** Whitmore Lake. 1800 sq. foot, 4 bd, 2 bath home currently set up as a duplex but could easily be converted to a single family home. Each level w/2 beds, 1 bath, living room & kitchen. (C-315FA) **\$175,000****LOCATION, LOCATION** Gorgeous colonial in prestigious Ridgewood West sub. 4 bd, 2.5 bath, huge Oak Kitchen w/island, hwd floors, master suite w/WIC & bath & many custom touches t/o. Clean as a whistle & ready to move in to. (C-111WO) **\$399,900****GREAT STARTER CONDO** 2 bd condo in great Canton location. Quiet community close to parks, schools, golf course, & xways. Plymouth canton schools. Perfect condo for under 100k. (C-738OR) **\$94,900****CUSTOM RANCH ON ACREAGE** Newer custom built ranch featuring 4 bds, 3 bas, on 7 acres. Plenty of room for storage in the 3 car Garage & 54x30 Pole Barn. Big open rooms w/vaulted ceilings, full finished walkout w/8 ft ceilings. (C-449RA) **\$450,000****LIVONIA BEAUTY** Fantastic find in popular Rosedale Gardens. 3 bd colonial featuring a FR w/vaulted ceiling, skylights & hwd floors. Formal dining & living w/hwd, updated Kit, fin bsmt, fabulous corner lot w/ privacy fence & brick pavers. (P-839IN) **\$234,900****GREAT LOCATION** Large Canton ranch in desirable Sunflower Sub. 3 bd, 2 baths, 1st floor laundry, full bsmt, 2 car garage & much more. (P-425BA) **\$229,900****BUYERS DREAM** Great curb appeal w/a double lot. Fenced yard w/beautiful tiered Deck, oversized driveway, new siding, trim, & doors. Many more updates to see. Call today. (P-533FE) **\$129,900****BUILDERS DREAM!** Multiple lots w/access to all sports Horseshoe Lake. 13 lots available, survey available. (P-000ID) **\$159,900****A MUST SEE!** Great colonial w/open floor plan, large Living & Family Room, Deck w/large pool, bsmt w/glass block, updated windows, carpet, & roof. Hurry! (P-110KA) **\$189,900****SIMPLY IRRESISTIBLE** No need to wait for builder on this almost new 2 bd, 2 bath townhome in the Links at Fellows Creek. Great Room w/frpl, Kitchen w/all appl, & a private balcony. (P-071KN) **\$159,900****TRULY UNIQUE** Magnificent colonial in popular Farm Hills sub. Oversized rooms t/o, gorgeous hwd, open Foyer, yard, & all appliances included. Move right in! inground pool in fenced yard backing to commons area. Too much to list! (P-834LJ) **\$449,900****GREAT STARTER HOME** 3 bd, 1.5 bath brick ranch w/many updates, lower level w/frpl, 3 season sun porch, fenced yard, & all appliances included. Move right in! (P-254ME) **\$164,900****IMMACULATE!** 3 bd, 1.5 bath ranch located in highly sought after sub. Updates include remodeled Kitchen, windows, roof, insulation, refinished hwd, elec, & Fieldstone frpl. Don't wait too long on this one. (C-424NO) **\$224,900****WOW!** Well maintained ranch on almost an acre. Oversized attached Garage, large eat in Kitchen w/Patio door to Florida Room, huge yard, hwd floors t/o, & wide open finished bsmt. A must see! (C-3800L) **\$190,000****NORTHVILLE/NOVI (248) 305-6090****CANTON (734) 392-6000****FARMINGTON (248) 478-6022****WESTLAND/GARDEN CITY (734) 392-6000****PLYMOUTH (734) 459-6000****LIVONIA (734) 425-6060**

June recognized as 'National Homeownership Month'

Realtors and Realtor associations across America are organizing homeownership and community improvement projects in June in honor of National Homeownership Month. President George W. Bush has proclaimed June "National Homeownership Month" to raise awareness of homeownership and encourage more Americans to consider the benefits of owning their own home.

To support that initiative and encourage member participation, the National Association of Realtors has provided

each state and local Realtor organization with a National Homeownership Month kit titled "It Takes a Realtor." The theme springs from the awareness that Realtors contribute to their communities and build better neighborhoods, towns and cities. It also illustrates how Realtors give their time to strengthen their communities by promoting legislation, wielding a hammer, and helping others.

NAR President Thomas M. Stevens said Realtors work in their communities to improve neighborhoods and increase

possibilities for homeownership. "Realtors build communities and we are carrying out the nation's housing mission - helping to elevate homeownership to more than 69 percent of U.S. households."

Proof of that is in the community improvement projects Realtors run, the homeownership workshops they sponsor, and the thousands of community-run programs to which they contribute. "Realtors and their associations are getting out and helping others because it's just good business to be a good citizen," said Stevens.

"Yet the work isn't finished," he said. "Realtors will keep donating their time to manage community improvement projects, and we will continue to speak up and work for everyone's homeownership rights. It's up to us to ensure that our voice comes through loud and clear. There's no challenge we can't overcome together."

The National Association of Realtors, "The Voice for Real Estate," is America's largest trade association, representing more than 1.3 million members involved in all aspects of the residential and commercial real estate industries.

**Grand Opening
Coming Soon**



BRAND NEW CONSTRUCTION! LAKES AREA COMMUNITY

Pre-construction prices starting at \$199,900

LIMITED OPPORTUNITIES
RANCH & LOFTED RANCH HOMES

Enjoy the convenience of many close-by amenities in this Lakes Area Community. Easy accessibility via I-275, I-96 and M-5 puts you within minutes of an extensive selection of shopping, restaurants, recreation and entertainment choices.

The ideal blend of a countryside-like location with close-by urban convenience can be yours when you come home to Greenbriar.

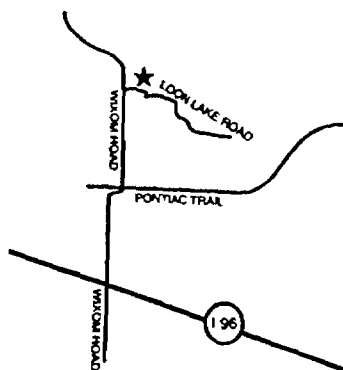

GREENBRIAR

presented by
**Phoenix Home
Building Company**
(248) 676-0154

www.phbco.com

Greenbriar is located in Southwest Oakland County, at the Northeast corner of Wixom Road and Loon Lake Road.

OUR PRIME LOCATION MAKES EVERYDAY *Easy*



GENOA WOODS CONDOMINIUMS

From the \$190s
Located in Brighton Area

- Ranch and 1-1/2 story attached condominiums
- All with first floor master suites
- Two & three bedrooms
- Great room and formal dining rooms
- 2-car attached garage

517-548-2030

To visit: I-96 exit Grand River. Follow Grand River west 4 miles just past Derr Road, on south side of Grand River Ave.



Models Open Daily 11-6pm
Brokers Welcome

ABBAY HOMES

Where the Living is Easy

Visit MyAbbeyHome.com
For more information on all communities!



www.hometownlife.com

REMERICA



INTEGRITY REALTORS

EARN EXTRA \$\$\$

Booming Real Estate Offices in Livonia and Northville are seeking outgoing Salespeople! Training Available.

Call Robert or Kim at:

734-525-4200 or 248-912-9990



Brownstown - Drastically reduced for quick sale! Beautiful and well kept 4 bed 2.5 bath home built in 1999. Beautiful hardwood in living and great room, ceramic tile in kitchen, nook and laundry. Marble fireplace in great room, nook with doorwall to patio. Beautiful finished bsmt with kitchen, 2 car garage. \$299,900 (08EM)



Dearborn Hgts - Beautifully updated 3 BR brick ranch. Updated light oak kitchen, updated bath, neutral paint, & new Berber carpet. New triple pane windows, entry screen doors, furnace & central air installed in 2005. 1.5 car garage and all appliances included. This home is a must see. \$399,900 (83AMH)

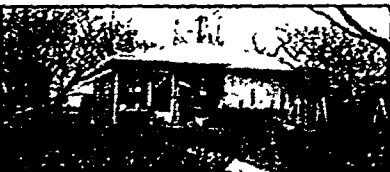

Dearborn Hgts - Spacious 3 bed 2 bath ranch on corner lot. Large modern eat in kitchen w/dining area. Updates in last 7 years include furnace w/C/A, windows w/marble sills, copper plumbing, circuit breakers, vented glass block windows in bsmt. 1100 sqft. \$126,900 (152CUR)



Garden City - Well maintained 3 BR 2 BA ranch. Home sits on nearly half an acre. Brand new kitchen installed in late 2005. Most appliances are included. Too many updates to mention. Gorgeous and peaceful Florida room to enjoy year round. This home should not be missed out on. You will not be disappointed. \$184,900 (1380C)



Farmington Hills - Everything has been done on this spacious 2 BR possible 3 BR ranch. Updates include a remodeled oak kitchen w/ceramic tile floors, updated baths, and freshly painted. Newer vinyl windows with marble sills. Natural fireplace in the living RM & basement. 1st floor laundry. This home is a must see! \$189,900 (75MID)



Livonia - Priced to sell! Charming 3 BR brick ranch with updates including new furnace & C/A, HWI windows & roof. Hardwood floors, updated kitchen and updated electrical. Partially finished basement with wet bar. This home is super clean and is waiting for its new owners. \$154,900 (715SL)

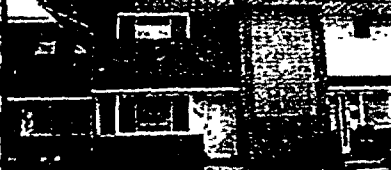

Livonia - Great value on this freshly painted 2 bed, 1.5 bath condo. Move in good lot! Nice hardwood floors, C/A, bsmt, one assigned space with additional parking lot in front. Complex is well kept, close to bus, church and shopping. \$69,900 (39MD)



Livonia - Vacant land! Property abuts City Park and Bell Creek. Irregular lot with 159' 93" frontage. Ideal lot for walk out basement. Total sqft of lot is 13,915. On a corner lot wooded and hilly ravine. \$49,900 (VACSUN)

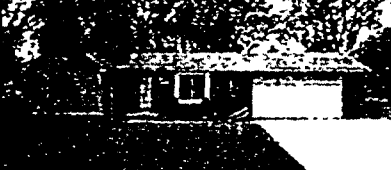

Livonia - Gorgeous! 3-bed 3 bath ranch on 1/2 acre lot built in 1994. Finished bsmt w/full bath, extra insulation gives this home the lowest gas bills in town. Sprinklers, deck, patio, 2 car garage has work area and wood burning system. Home warranty, C/A, security alarm. \$219,900 (71AMH)



Livonia - Lovely 3 bed, 1.5 bath brick ranch. Spotlessly clean! Updated bath, newer windows & furnace. nice gas fireplace in LR, very spacious, gorgeous Florida room. Extra wide driveway, beautiful curb appeal. Home warranty, 1300+ sqft bsmt, sprinklers, garage, C/A. \$229,900 (45HOU)



Northville - A rare find! This 6 BR, 4.2 BA Victorian style sits on 2.5 acres backing to Maybury State Park. Private spring led pond. Home offers over 9000 sq ft of living space including walkout, media room, rec room, and 5 1/2 replaces. Too many details to mention. This home is unbelievable. \$1,989,000 (10WES)



Northville - Beautiful 4 BR, 3.1 BA colonial in Woodside Village. Spacious kitchen & nook boasts Jen-Air appliances. Custom window treatments, crown moldings, & twin bay windows. Master Suite w/bath offers separate shower, jetted tub & double vanity. Extra deep finished lower level w/full bath & kitchen. 2 tiered deck overlooks private woods. \$465,000 (56WOO)



Northville - Wow, this is your next home! This 3 BR, 2.1 BA ranch is beautiful inside & out. Everything has been done for you, just move in and enjoy! Gorgeous quiet pool & spa are ready for sun & fun in the summer. Enjoy your own private retreat which backs to the commons! Home warranty included. \$385,000 (85BAN)

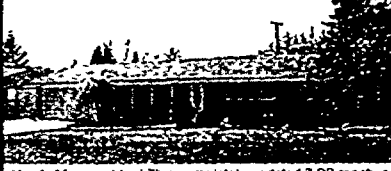

Novi - Move right in! This completely updated 3 BR ranch is in a desirable location. Custom kitchen w/island & breakfast room. Hardwood flooring, updated roof, furnace & C/A. Beautifully landscaped backyard w/custom stamped concrete patio & driveway. Finished garage w/new insulated door. \$199,900 (211EB)

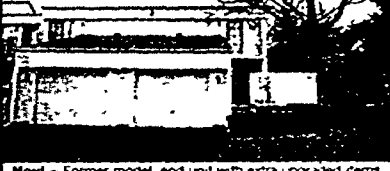

Novi - Former model, and unit with extra upgraded items. 2 bedrooms with full ceramic baths. 2.5 baths. Living room w/gas fireplace and doorwall to patio. Ceramic floor in white kitchen w/recessed lights. Finished bsmt w/office, C/A, bsmt, sprinklers, garage and 1300 sqft. \$169,900 (22C0U)



Novi - This one is a beauty! 2 BR, 1.5 BA condo with an enormous master suite. Hardwood floors in living room. Newer carpeting, private basement and newer windows. 1 car attached garage & 1 assigned space. Gas and water are included. Close to everything. Hurry - one won't last! \$145,000 (36SDT)



Deerpark - Beautiful corner lot, 2 story colonial w/3 bedrooms and 2.5 baths built in 1997. Kitchen w/built in appliances, hardwood floors. Master w/separate bath and walk in closet. Corner lot w/wrap around deck and playground. C/A, bsmt, 2 car attached garage. 1500+ sqft. \$210,900 (54CAS)



Redford - Awesome & spacious 3 BR 2 BA brick ranch. Ceramic floor, tray & coed ceilings in living & dining rooms. Beautiful gourmet kitchen offers an island and plenty of counter space & cabinets. 1st floor laundry, full part all in finished basement and a 2 car attached garage. This home is a beauty. \$189,900 (36WES)



Redford - Totally remodeled 3 bed ranch. Everything is updated! Bsmt newer appliances stay fenced in yard w/deck & shed, garage, 1000+ sqft. Updated roof, windows, carpet, vinyl C/A, hardwood kitchen & bath. Hardwood floors throughout with new landscaping and home warranty. \$137,430 (41AM)



Redford - Check out this 3 bed ranch, some wood floors, remodeled kitchen w/oak cabinets. Newer kitchen floor, breakfast nook overlooks family room. Newer vinyl windows, sliding furnace & C/A. Freshly painted, purified water system, bsmt fenced yard, garage. 1100+ sqft. \$124,900 (29LEX)



Redford - Adorable 3 bed ranch with home warranty. Updates include new kitchen floor, new roof, gutters, furnace and water heater. Large fenced backyard, stove & fridge stay, fenced yard. Almost 1000 sqft. \$97,500 (67DAL)

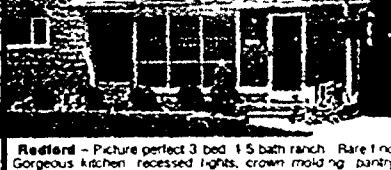

Redford - Picture perfect 3 bed, 1.5 bath ranch. Rare find! Gorgeous kitchen, recessed lights, crown molding, pantry, lots of counter space and cabinets. Nice carpet in LR, mfr door closet in 2 bedrooms. 2 car garage, sprinklers, fenced yard. Finished bsmt. 1100+ sqft. \$159,900 (29LEV)

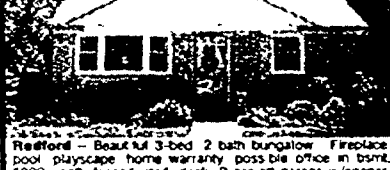

Redford - Beautiful 3-bed 2-bath bungalow. Fireplace, pool, playground, home warranty, possible office in bsmt. 1300+ sqft, fenced yard, deck, 2 car attached garage w/open most appliances stay. C/A. \$149,900 (42NOR)



South Lyon - Ready to move in! 3 BR, 1.5 BA ranch has been freshly painted, new carpet installed and a new roof. Partially finished basement and a 2 car detached garage. Walking distance to parks and to downtown South Lyon. This is a great home. Don't miss out on this one! \$174,900 (66NOR)

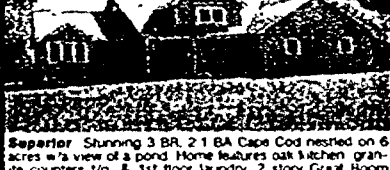

Superior - Stunning 3 BR, 2.1 BA Cape Cod nestled on 6 acres w/a view of a pond. Home features oak kitchen, granite counters, 1st & 2nd floor laundry, 2 story Great Room w/ vaulted ceiling & a 2 story stone gas FP. Master Suite w/private bath including dual sinks & jetted tub. 2 car garage and a large pole barn. \$629,900 (66JOY)



Taylor - Wow, this 3 BR ranch sits on almost 1 acre! This is a truly turn the key home. Home offers cathedral ceilings in the family room, neutral decor, wallside vinyl windows & central air. Private Master Suite w/large closets. 2 car detached garage. Home warranty included. \$179,900 (51BEE)



Warren - Reduced \$10,000 for quick sale! Very sharp 3-bed ranch built in 1984. Remodeled bath, C/A in 96, furnace in 97, newer HWI paint and carpet through out. Nicely decorated finished bsmt w/bedroom and rec room. Move in condition! \$114,900 (43TIM)

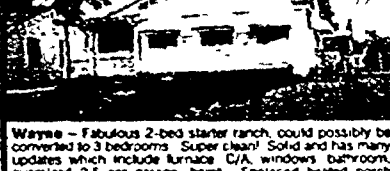

Warren - Fabulous 2-bed starter ranch, could possibly be converted to 3 bedrooms. Super clean! Solid and has many updates which include furnace, C/A, windows, bathroom, oversized 2.5 car garage, bsmt. Enclosed heated porch could be a great library! Home warranty, fenced yard, garage. \$119,900 (42NIE)

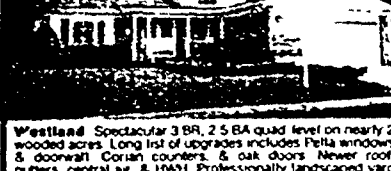

Westland - Spectacular 3 BR, 2.5 BA quad level on nearly 2 wooded acres. Long list of upgrades includes Pella windows & doorwall, Corian counters, & oak doors. Newer roof, gutters, central air & HWI. Professionally landscaped yard offers hot tub & heated pool. Stamped concrete & aggregate patio, sprinklers, and shed. \$294,900 (43SIE)



Westland - Ideal home to raise a family! This beautiful 4 BR, 2.1 BA home is simply amazing. Elegantly finished basement with terrific storage. Beautiful custom interior design. Huge kitchen with breakfast dining area opens to family room w/FP. Ceramic Master bath w/spa, HW floors & more. \$327,000 (11CAS)

Two Locations for your Convenience

LIVONIA • 734-525-4200

NORTHVILLE • 248-912-9990

www.Remericaintegrity.com

Door of opportunity is still open

(NAPSI) — Despite some less than encouraging news about nationwide conditions in the real estate market, this can still be a good time for consumers looking to purchase a home. Recent trends toward stabilizing prices, moderating appreciation rates and increasing inventory all work in the favor of homebuyers for several reasons.

First, consumers should realize that "all real estate is local." National statistics are weighed heavily by what hap-

pens in large markets at the extremes and don't take into consideration many factors that impact local changes in pricing and inventory, such as business growth, employment and other aspects unique to each community.

Increased inventory also means more choices, more time to look at more properties and, once buyers find the home they want to purchase, more room for negotiation. Closing costs, special assessments, personal property

and other terms and contingencies that had been nonnegotiable are again open for discussion. Offers that in a hot seller's market would have gotten laughed off the table are now getting serious consideration, counteroffers and even accepted.

Not only that, but with more properties staying on the market longer and longer, and with fewer and fewer buyers competing for them, some of the pressure on buyers has been reduced. Often

in hot seller's markets, conditions dictate so much of what buyers are able to do, driving so many of their decisions. The pressures of such a market can even force consumers who have to buy — transferees or retirees, for example — to just "settle" on properties that they might not otherwise purchase under other circumstances. But as the pace slows, patience can again become the virtue that it should be, instead of a victim of the market.

BRIGHTON'S BEST NEW CONDO VALUE!

Grand Opening



Year-round Lakefront Living

Priced from

\$169,900

Woodruff Lake Ridge

- 65 Acre Lake
- Dock
- Sand Beach
- Swimming
- Fishing

MODEL HOURS:

Friday - Sunday 1-5
or by appointment

(248) 505-5992

RE/MAX
Classic

1042 N. Milford Road
Milford, MI 48381

brenta@rieli.net

New Condominiums to fit your needs!

- Immediate occupancy
- Granite countertops
- Master suites
- 2 bedrooms & 2 full baths
- Large kitchens
- All appliances included
- Fireplaces
- Air conditioning
- All-sports lake access
- Close to downtown Brighton
- Brighton Township
- Brighton schools
- Low tax base
- Central location
- Close to freeways
- Minutes to Island Lake & Kensington

BROKERS WELCOME



View these homes and the entire MLS at www.BrentRieli.com

THE OBSERVER & ECCENTRIC MORTGAGE MONITOR

		30 Yr.	Pts.	15 Yr.	Pts.	Other
1st Choice Mortgage Lending	(734) 459-0782	6.625	0	6.25	0	J/A
A Best Financial Corp.	(800) 839-8918	6.125	1.625	5.625	2.125	J/A
A Perfect Mortgage Co.	(248) 203-7726	6.625	0	6.25	0	J/A
AAXA Discount Mortgage	(877) 728-3569	6.5	0.25	6.125	0.25	J/A
AFI Financial	(877) 234-0600	6.375	0.625	6	0.75	J/A
American Home Mortgage	(877) 478-7289	6.25	2	5.875	2	J/A/V/F
Ameriplus Mortgage Corp.	(248) 740-2323	6.5	0.25	6.25	0	J/A
Brighton Commerce Bank	(810) 220-8646	6.875	0	6.5	0	J/A
Brinks Goldstar Mortgage	(800) 785-4755	6.25	1.25	6	0.75	J/A/V/E
Capital Mortgage Funding	(248) 569-7283	6.625	1.5	6.375	1.5	J/A/F
Centerbrook Mortgage	(248) 851-4150	NR	NR	NR	NR	J/A
Charter One Bank	(800) 342-5336	7	0	6.625	0	J/A/V/F
Client Services by Golden Rule	(800) 569-5805	6.125	1.625	5.75	1.625	J/A/V/F
Co-op Services Credit Union	(734) 466-6113	7	0	6.75	0	J
Community Bank of Dearborn	(734) 981-0022	6.75	0	6.375	0	J/A/V/E
Credit Union One	(800) 544-5567	7	0	6.625	0	J/A
Dearborn Federal Savings Bank	(313) 565-3100	6.625	0	6.25	0	A
DFCU Financial	(800) 739-2770	6.5	2	6	2	J/A
Downriver Community FCU	(313) 386-2200	7	0	6.5	0	J/A
Earth Mortgage	(877) 327-8450	6.625	0	6.25	0	J/A/V/F
Fifth Third Bank	(800) 792-8830	6.75	0.125	6.375	0.25	J/V/F
First Alliance Mortgage Co.	(800) 292-7357	6.625	0	6.5	0	J/A/V/F
First International Mortgage	(248) 540-1065	6.625	0	6.25	0	J/A
GMAC Mortgage Corp.	(800) 888-4622	6.25	3	5.875	3	J/A/V/F
Golden Rule Mortgage	(800) 991-9922	6	2.125	5.625	2.125	J/A/V/F
Goldstar Mortgage	(800) 784-1074	6.625	0	6.25	0	J/A/V/F
Group One Mortgage	(734) 953-4000	6.75	0	6.375	0	J/A/V/F
LaSalle Bank Midwest	(800) 466-3800	6.375	2	6	2	J/A/V/F
Mainstreet Mortgage	(800) 900-1313	6.625	0	6.25	0	J/A/V/F
Manufacturers	(586) 777-1000	6.125	2	5.75	2	J/A
Michigan Schools & Gov, C/U	(586) 263-8800	6.75	0	6.375	0	J/A
Mortgages by Golden Rule	(800) 991-9922	6.25	1.125	5.875	1.125	J/A/V/F
National City Bank	(586) 825-0625	6.375	1.875	6	2.125	J/A
Northlawn Financial	(248) 988-8488	6.625	0	6.25	0	J/A/V/F
Pathway Financial LLC	(800) 726-2274	6.625	0	6.25	0	J/A/F
Peoples Mortgage	(800) 730-5087	6.375	0.625	6	0.75	J/A
Premiere Mortgage Funding	(800) 684-7880	6.625	0	6.25	0	J/A
Shore Mortgage	(800) 678-6663	6.125	3	6	3	J/A/V/F
United Mortgage Group	(586) 286-9500	6.625	0	6.25	0	J/A
York Financial Inc.	(888) 839-9675	6.625	0	6.25	0	J/A

Above information available as of 6/23/06 and subject to change at anytime. Rates are based on a \$200,000 loan with 20% down. Jumbo rates, specific payment calculations & most current rates available Fridays after 2:00 P.M. at www.rmcreport.com. Key to "Other" Column - J = Jumbo, A = Arms, V = VA, F = FHA & NR = Not Reported. All Lenders are Equal Opportunity Lenders. ☺

© Copyright 2006 Residential Mortgage Consultants, Inc., All Rights Reserved



BUILDING APPRECIATION™

SINGLE-FAMILY NEIGHBORHOODS

From the low \$200's

MARLEE WOODS
 Convenient location to shopping and more! Landscape package included!

MODEL NOW OPEN!

WESTLAND (734) 266-2700
 I-275 to Ford Rd. (exit 25) travel East; located on the West side of Farmington Rd., North of Ford Rd.

From the upper \$200's

THE GLENS AT CRYSTAL CREEK

MODEL NOW OPEN!

South Lyon Schools.
 Landscape package included!
LYON TWP. (248) 437-0022
 I-96 to Milford Road travel South on Milford Road to 11 Mile Rd.

From the low \$200's

AMBERLY WOODS
 Minutes from Downtown Howell. Acclaimed Howell Schools. Landscape package included!

MODEL NOW OPEN!

HOWELL (517) 545-2800
 South of M-59 on the West side of Eager Rd.

From the \$240's

HARBOR VILLAGE
 Next to country club, lakes and rails-to-trails. West Bloomfield Schools! Landscape Included!

KEEGO HARBOR/ W. BLOOMFIELD (248) 706-5900
 Summers, East of Orchard Lake Rd. just North of Commerce Rd.

From the low \$300's

HILLS OF BOGIE LAKE
 Clubhouse, pool, sports court & more! 3-Car garages and landscape package included!

COMMERCE TWP. (248) 366-2800
 On Bogie Lake Rd., South of Cooley Lake Rd.

From the mid \$200's

LAKERIDGE AT WATERSTONE
 Surrounded by 15 pristine lakes and 27 holes of world-class golf

OXFORD (248) 628-0500
 Seymour Lake Road, just West of Lapeer Rd.

IVANHOE HUNTLEY™
 HOMES
www.ivanhoehuntley.com

CONDOMINIUM NEIGHBORHOODS

From the low \$200's

THE VILLAS AT CRYSTAL CREEK
 Paired condominium homes. Acres of natural preservation areas.

2 MODELS NOW OPEN!

LYON TWP. (248) 446-0005
 I-96 to Milford Rd. travel South on Milford Rd. to 11 Mile Rd.

From the mid \$200's

STONY LAKE AT WATERSTONE
 Paired lakefront ranch & lofted-ranch condominiums; 27 holes of world-class golf

OXFORD (248) 236-9630
 West side of Lapeer Rd., North of downtown Oxford

From the low \$200's

WILLIAMS LAKE CROSSINGS
 Paired condominium homes. Community pool house and pool

WHITE LAKE/ W. BLOOMFIELD (248) 698-7860
 On Williams Lake Rd., S. of Elizabeth Lake Rd.

From the \$140's

HARRISON COVE
 Adjacent to Lake St. Clair. Community clubhouse, pool, spa, and workout & business centers

HARRISON TWP. (586) 792-6700
 On Jefferson, between Crocker and Shook Roads

From the \$150's

TOWNE CENTRE PARK
 In-Town Convenience - Walk to shops! Attached garages. Community pool and cabana

WATERFORD (248) 673-3445
 West side of Crescent Lake Rd., N. of Pontiac Lake Rd., S. of M-59 (Highland Rd.)

**SALES CENTERS
 OPEN DAILY
 11-6 P.M.
 or by appointment**

www.ivanhoehuntley.com



Research shows public workers often struggle with owning home

Teachers and police officers in the District of Columbia; Fairfax County, Va.; and Frederick County, Md., can't afford to own a home in the communities where they work. Neither can police

officers in Dover, Del.; social workers in Richmond, Va.; or municipal court clerks in Kent County, Md. That was the gist of studies released recently by the National Association of Realtors at

NAR's Mid-Atlantic Regional Summit on Housing Opportunities.

The new "Paycheck to Paycheck" analyses of incomes and housing costs in 13 localities in the four-state Mid-Atlantic Region and the District of Columbia were conducted by the National Housing Conference's Center for Housing Research. Communities studied were Prince George's County, Md.; Prince William County, Va.; Baltimore County-Towson, Md.; Frederick, Md.; New Castle, Del.; Charleston, W.Va.; Fairfax, Va.; Cumberland, Md.; Dover, Del.; Washington, D.C.; and Richmond, Va.

"This growing issue isn't just about the ability to buy a home. Lack of affordable housing diminishes the quality of life for everyone in the community. Workers who devote a disproportionate share of their income to housing are forced to cut back on other necessi-

ties, such as health care," said NAR President Thomas M. Stevens of Vienna, Va.

Stevens announced NAR is launching a new campaign to create more affordable housing opportunities for public and private sector workers by encouraging and training Realtors nationwide to work with employers to develop employee-assisted housing benefit plans for their workers. The new program, called "Home from Work," is already in place in two state Realtor associations, Florida and Arizona. Realtors are holding home-buying workshops for employees, arranging one-on-one counseling through non-profit groups and helping to arrange financial incentives for buyers. Training will be offered later this year to Realtors in the Mid-Atlantic Region as well as

PLEASE SEE WORKERS, 20

You'll find more property listings in the Classified sections of these fine community newspapers:

Birmingham Eccentric
Canton Observer
Farmington Observer
Garden City Observer
Livonia Observer
Milford Times
Northville Record
Novi News
Plymouth Observer
Rochester Eccentric



Royal Oak and Clawson Mirror
Redford Observer
Southfield Eccentric
South Lyon Herald
Troy Eccentric
West Bloomfield Eccentric
Westland Observer
and on
HOMETOWNlife.com

LET'S MAKE A DEAL

adlerhomes.com

HOWELL

PINEVIEW VILLAGE

(517) 545-8631

196 Exit 133 onto M59 east. Two miles on north side. Located across from the Citizens Insurance Building.

Townhomes
from the
NEW \$130's

Up to 3 Bedrooms • 2 1/2 Baths • 2 Car Attached Garage

Everything Is Included!

- Refrigerator
- Full Size Washer and Dryer
- Range
- Window Treatments
- Microwave

HOWELL

COPPERFIELD VILLAGE

(517) 552-4499

196 to Exit 137, South on (D-19) 1/2 mile, turn left (east) on Francis Rd.

Single Family Homes
from the mid
\$190's

Ranch • 2 Story • 1 1/2 Story

On 1/2 acre or Larger Homesites

BRIGHTON

SPRING HILL

(810) 229-5722

196 Exit 145 onto Grand River south to First Rd. turn east. OR 196 Exit 147 onto Spencer Rd. west to Grand River north, turn east on First Rd.

Detached Condominiums
from the mid
\$200's

Preconstruction Pricing

Furnished Models Open Daily 12-6 pm

ATTENTION BROKERS:
We pay 3% commission!

10 Year Warranty

SWEAT EQUITY PAYS!
Help Yourself and SAVE BIG
on Your New Adler Home!
For further information call the sales consultant.

FREE CREDIT REPORT for ATTENDING

How To Buy Your First Home FREE SEMINAR!

Sponsored by Approved Mortgage, Inc.

You may be able to buy your first home sooner than you thought possible, even if your credit isn't perfect. We'll answer your questions:

100% Financing Programs Are Now Available

- Can I qualify for a mortgage?
- How much home can I afford?
- How much money do I need for the down payment?
- Is my credit okay?

Wed. July 12th • 7-8:30 p.m.
46000 Summit Parkway • Canton

For Reservations Call Jill Jacobs
734-455-2219 ext. 220



View Every Home in the Multiple Listing Service at
Century21Town-Country.com

Preview Hundreds of Open Houses Throughout the Week at
TCopens.com



LYON TOWNSHIP
 Unbeatable 4 BR, 2.5 BA cape cod w/1st floor master ste, FFL, 3 car gar, fin bsmt, deck w/hot tub & move-in ready. Great location & sitting on a beautiful 1+ acre lot.
 (T67WAL) \$375,000 248-349-5600



SOUTH LYON
 Tanglewood condo on 3rd fairway. 3 BR with 1st floor MBR. Study or 4th BR also. Eat-in kit offers convenience & storage. Open LR/DR & large windows for plenty of light.
 (T28SAW) \$369,800 248-349-5600



NOVI
 2 BR, 2 BA condo w/top of the line materials T/O. You will take one look and will fall in love. Finished daylight basement. Crown molding T/O, except BR s.
 (T01ADA) \$249,900 248-349-5600

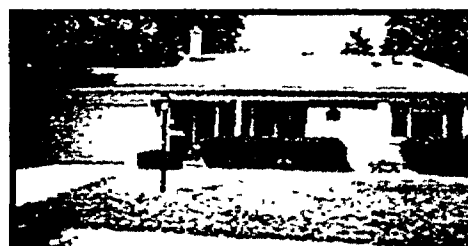

LIVONIA
 Sharp 3 BR, 2 BA home. Recently redone. Hardwood flrs, newer baths, fresh paint, newer carpet & windows. Fin LL, 2 car attached gar. Great neighborhood. Great location. Must see.
 (T54RAV) \$224,900 248-349-5600



LIVONIA
 The kitchen is the heart of this home-beautiful white Kraftmaid cabs, double ovens, Corian counters. 4 BR, FR w/frpc, great corner lot, 3 car drive, extra parking in private yard.
 (T51EDG) \$254,900 248-349-5600



CANTON
 Nicely updated 3 BR, 1.5 BA col. Oak finish cabs & newer floor in kit-newer vinyl windows, furn & A/C. Hrdwd floors in BR s. Frpc in FR. Large yard for summer fun.
 (T19ORH) \$194,900 248-349-5600



LIVONIA
 Wonderful 3 BR brick ranch in popular Tiffany Park sub. Full bsmt, 2 car att gar, FR, deck, newer furn & roof. Country size kit. Fenced yard & more. One year home warranty.
 (T15GRE) \$214,900 248-349-5600

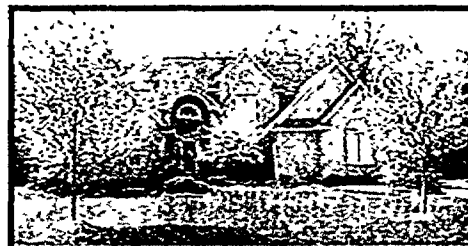

SOUTH LYON
 Tanglewood sub. 3BR, 2.5BA cape cod on awesome wooded lot. Shows like a model. Newer furn & carpet. Fin LL. Immediate Occupancy. Seller will help with buyers closing costs.
 (T59SAI) \$499,900 248-349-5600



HOWELL
 Shows like a model. Upgrades T/O. Open floor plan w/2 BR & 2 BA. Kit w/ceramic floor, oak cabs & all appliances included. Park-like setting. Great location. A must see.
 (T58OLD) \$134,900 248-349-5600



LIVONIA
 Your search stops here! You'll love all the square footage this spotless ranch offers. Huge kitchen w/refaced cabs, FR w/frpc, Fla room, full bsmt, att gar & tons of updates.
 (T47SUN) \$204,900 248-349-5600



LIVONIA
 Unbeatable 2 story colonial w/stunning updated kit w/granite counters, formal DR, FR w/frpc, multi-level deck, large yard & too many updates to list. Better hurry.
 (T55BAI) \$179,900 248-349-5600

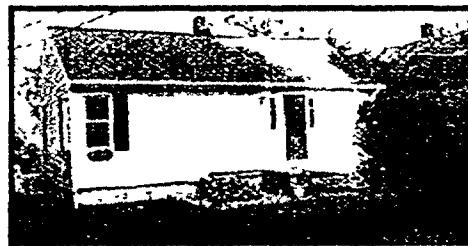

AUBURN HILLS
 Picture perfect w/newer roof, furn, HWH, electrical, Pella windows, stunning decor, bsmt on a large beautifully landscaped country lot. Updated kit w/parquet floor.
 (T30GUA) \$139,900 248-349-5600



NOVI
 Should be on a magazine cover. 4 BR, 4.5 BA, 2-sty foyer, 2-sty FR w/gas frpc, kit w/island, lib, Jack-N-Jill BA, MBR retreat, fin bsmt w/wet bar, 3 car side entry gar & updates.
 (T50ROX) \$570,000 248-349-5600



HISTORIC HOME
 Lovely 3 BR colonial on double lot. Many updates including: Pergo floors, plus some hrdwd. New roof in 02. Landscaping. Close to water, parks & historic downtown.
 (T31SEC) \$138,000 248-349-5600



GREAT LOCATION
 Newer condo built in 04. Open floor plan, bay window, stainless steel appls & maple cabs. MBR has pvt BA & huge WIC. Att gar, pvt entrance. Clubhouse & pool.
 (T41ABB) \$165,000 248-349-5600

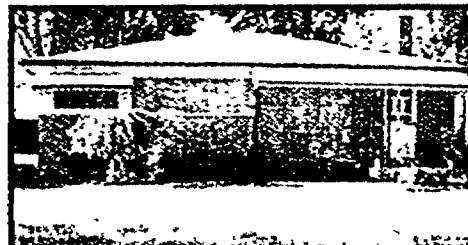

WESTLAND
 Livonia schools. 3 BR, 2 BA brick ranch. Partially fin bsmt, 2 car garage. Newer windows, electric, furn. All appliances included. Home warranty. Nicely landscaped. A great home.
 (T02BER) \$154,900 248-349-5600



GARDEN CITY
 Style & charm. 3 bedroom home w/new furnace, roof and windows in 2006. Updated kitchen and bath. Neutral throughout. First floor laundry. Come see for yourself.
 (T08CAM) \$150,000 248-349-5600



FARMINGTON HILLS
 Two bedrooms, 1.5 baths, fresh paint, newer Berber carpeting, window treatments, lighting, storm door, dishwasher and more. Finished basement and one car garage.
 (T23COU) \$142,900 248-349-5600



WESTLAND
 Gorgeous newer 2 BR, 1.5 BA townhouse w/fin bsmt & 2 car att gar. FFL w/extra pantry. Both BR s w/cathedral ceilings. Freshly painted. Large LR w/marble frpc.
 (T74DER) \$159,900 248-349-5600



WALLED LAKE
 Super location! Clean & updated 2 BR, 1.5 BA condo w/full bsmt, att gar, huge MBR w/WIC, frpc, Pergo floor in kit, crown molding, newer neu carpet. All appliances included & more.
 (T74DOV) \$149,900 248-349-5600

MICHIGAN'S NUMBER ONE CENTURY 21® FIRM



<p>HIGHLAND Impeccable custom Cape Cod w/ 3 BR, 2.5 BA. Very open, frpic in GR. Lux FF mst. Island kit opens to bay window nook. Custom moldings, deluxe lighting. Bsmt, 3 car garage, LK Ptv. (T78ANC) \$399,900 248-363-1200</p>	<p>WEST BLOOMFIELD 3 bedroom brick Ranch situated on 1/2 acre lot. Features completely updated kitchen and bath, frpic, bsmt, 2+ gar, newer windows, furnace, water heater, patio, lake privileges (T51DAR) \$225,000 248-363-1200</p>	<p>MILFORD Impressive, quality, custom, new built home. Beautiful pond view setting. Crown moldings on first floor. Gorgeous maple kit, library/DR wainscot. W/O bsmt, High ceilings. Ready. (T310LU) \$350,000 248-363-1200</p>	<p>FARMINGTON HILLS READY, SET, MOVE! Deep into Copper Creek & at the highest point is this golf community beauty! 3 BR, 4 BA w/GR, formal DR, study & kitchen. Pro fin LL w/BR, BA, wet bar & lots of storage. (T64GOL) \$390,000 248-626-8800</p>	<p>WATERFRONT WATERFRONT LIVING w/DOCK Newer custom granite kit, hardwood flooring & carpeting. LR w/ granite FP, FR and DR. Dock your boat in front of heated parking steps from front door. (T65POR) \$295,000 248-626-8800</p>	<p>CANTON SPECTACULAR COLONIAL 4 bdrm, 2.5 bath home in the premier Glengarry Village Sub. Very open fr plan great for entertaining, updated kit in 05, bsmt & 2 c att gar. (T68DAN) \$354,900 734-455-5600</p>	<p>WESTLAND A PLACE TO CALL HOME Charming 3 bdrm, 2 bath ranch offers 2.5 car garage, fam rm w/frpic & 2 doorwalls, part fin bsmt, & above ground pool. Newer roof and furnace. (T69MAE) \$179,900 734-455-5600</p>	<p>LIVONIA Great price & updates. 3BR, 2.5BA w/fin bsmt & gar. Newer roof, furn, C/A & windows. Remodeled kit & BA. Livonia schools & home warranty. (T84GRA) \$149,800 248-349-5600</p>	<p>WEST BLOOMFIELD Spacious 4BR, 2.5BA col on a premium lot, boasts beautiful landscaping, GR w/frpic, prt study w/French doors, large kit w/eat-in area looking out to the deck. Master ste w/dressing area. (T20MIL) \$424,900 248-349-5600</p>
<p>WEST BLOOMFIELD Great party kitchen with island and plenty of cabinets, 3 BR, 3 BA. Gently curved staircase to upper BRs Walled Lake schools, deck off kitchen, gas frpic and wet bar in family room (T31ANN) \$269,900 248-363-1200</p>	<p>HIGHLAND Private/quiet approx. 10 acre estate inside approx. 6,000 acre state park. New equestrian stables & paddocks, direct access to snowmobile & horse trails. (T31DUC) \$1,300,000 248-363-1200</p>	<p>MILFORD Peaceful, private 3+ acre setting w/ woods and pole barn near Kensington Metropark. Sharp home w/ updated kitchen, bath, windows and more. fireplace, C/A, bered paver patio. (T25PEA) \$290,000 248-363-1200</p>	<p>LIVONIA EXTENSIVELY UPDATED 3 BR ranch, remodeled kitchen, newer windows, exposed hardwood floors in LR, hall & all BRs. FR with FP & downwall to deck. Partial finished basement LL. 2-car garage (T40LEO) \$204,900 248-626-8800</p>	<p>FARMINGTON HILLS SPRAWLING BRICK RANCH 4 BR, 2.5 BA on huge lot. Full bsmt. FFL 2 car att side entry gar. Circular driveway. MBR has dressing room or nursery. Home warranty. (T50SPR) \$224,900 248-626-8800</p>	<p>PLYMOUTH BEAUTIFUL COUNTRY HOME 5 bdrm, 4 bath 19th century colonial on approx 2.9 acres. Great mstr bdrm, hrdwd frs, country kit & formal din rm. Pond, deck & gazebo. A must see! (T66HOM) \$450,000 734-455-5600</p>	<p>GARDEN CITY CHARM & CHARACTER 1930's farm house on a lg private lot offers 4 bdrms, 2 ceramic baths, oversized 2 c gar, bsmt, Florida rm on the 2nd floor, & 2 bered deck off kitchen. (T17JOH) \$190,000 734-455-5600</p>	<p>LIVONIA Updated 3BR ranch in the past 10 years: furn, A/C, kit, roof, windows, trim & gutters. Basement w/ block windows, electrical & plumbing. Sharp. (T95HAT) \$164,900 248-349-5600</p>	<p>SOUTH LYON Lake privileges 55+ ranch w/2BR, 2BA, C/A, Florida, finished lower level, garage & covered porch, plus clubhouse & beach on Crooked Lake. (T19NAN) \$139,900 248-349-5600</p>
<p>WEST BLOOMFIELD 3 wooded lots, lake priv, at 3 beaches avail Great open floor plan for entertaining. All newly redecorated & great room w/ hardwood floors 2 story garage 3 bedroom. Walled Lake schools (T71BUN) \$189,900 248-363-1200</p>	<p>MILFORD Exquisitely finished Stoneridge lakefront. Defining features include conservatory, island kitchen, deck with screened gazebo Deluxe master suite. Beautifully landscaped (T88EXE) \$549,900 248-363-1200</p>	<p>WEST BLOOMFIELD Gorgeous 4 BR, 2.5 BA custom beauty. First floor master. Huge kitchen. Breakfast nook and sun/keeping room 3 car garage. A must see home W. Bloomfield schools. Great first floor laundry. (T85SAD) \$383,000 248-363-1200</p>	<p>NOVI A BEAUTY Newer hardwood floors in formal dining room, kitchen and breakfast room. Spacious great room with fireplace and library 3 bedroom, 2.5 bath. First floor laundry (T02MAR) \$295,000 248-626-8800</p>	<p>FARMINGTON HILLS CAPE COD Boasts 2-story decks overlooking breathtaking acre lot Huge GR w/natural FP. FFL. Big kitchen w/bonus room. DR. Hardwood floors under most carpet. Finished walkout basement. (T00SPR) \$369,000 248-626-8800</p>	<p>CANTON NEW CONST HOME Elegant cape cod w/4 bdrm, 3.5 bath, 4 c att gar, 1st fl mstr, WIC & bath w/ garden tub, cath ceiling in foyer & great rm. Kit w/ granite tops, grand staircase. (T02ROL) \$810,000 734-455-5600</p>	<p>VAN BUREN NEWER CAPE COD 3 bdrm, 2.5 baths, open fr plan, maple kit w/island, ceramic mstr bath w/ separate shower, great rm w/frpic, hrdwd fir entry, 2 c att gar, FFL & bsmt. (T22DAN) \$242,900 734-455-5600</p>	<p>HOWELL Stunning ranch condo w/lots of upgrades: rolling showers, low countertops, upgraded carpet, kit w/ roll-in lunch counter. Upgraded appls. Security system & intercom for added piece of mind. (T60KNE) \$149,900 248-349-5600</p>	<p>LIVONIA Turn-key ranch. Homey 3BR, 2BA w/bsmt & garage. Super fin bsmt w/FR & office. Lots of updates in BA's, kit, furnace, A/C, HWH & more. Newer appliances (T89ORG) \$169,900 248-349-5600</p>
<p>COMMERCE Lake Sherwood lakefront, 3 BR, 3.5 BA custom built w/ fin. walk-out and 2 car gar. 120+ ft. of frontage, sandy beach, dock & hoist. Gorgeous inside and out Panoramic views (T21COM) \$550,000 248-363-1200</p>	<p>COMMERCE The ideal home with the ideal location Impeccable 3 BR, 2 BA Ranch on a large wooded cul-de-sac lot. Finished bsmt, family room w/ door wall to deck. City water, Walled Lake schools (T35JEN) \$269,900 248-363-1200</p>	<p>COMMERCE TOWNSHIP 4-5 BR, 3 BA, fin w/o Ranch w/ extra kitchen in LL. Home boasts hrdwd frs, cath ceiling, 1st fl laundry & spectacular staircase, deck & patio, lg lot overlooks nature preserve (T00STO) \$392,000 248-363-1200</p>	<p>NOVI Transferee mourns loss, newer 4 BR in small community that co-owns beach lot on Walled Lake. Hardwood floors, granite counters, walkout. Backs to wooded preserve. Never deck & paver patio (T95WOR) \$449,900 248-626-8800</p>	<p>FARMINGTON HILLS 4 BR, Updated kit, ceramic tile flo, bsmt w/cedar wood closet, newer windows, double front door, gar door opener, circular dr, MBR w/built-ins & full BA, inground pool w/hot tub, lib w/ French doors. (T20STO) \$369,900 248-626-8800</p>	<p>WIXOM PERFECTION PLUS in this 4 bdrm, 2.5 bath colonial built in 2002 offering 3 c att gar, full bsmt, hrdwd floors, bay window in d'ning rm, fam rm with custom frpic, & sprinklers (T71POT) \$282,500 734-455-5600</p>	<p>CANTON SUNFLOWER VILLAGE 4 bdrms, 2.5 baths, updates incl. roof, windows, furn, carpet, deck & the list goes on 2 c att gar, bsmt, FR w/frpic, formal din rm & lg eat in kit (T72CLA) \$235,000 734-455-5600</p>	<p>GREEN OAK 55+ RANCH WALKOUT Sunny ranch w/O w/3BR & 2 full ceramic BA's. Fla room, recently painted, covered front porch, 1 car gar, clubhouse & beach on Crooked Lake (T08LEX) \$150,000 248-349-5600</p>	<p>BROWNSTOWN Beauty from door to deck. Brck ranch condo new 05 Open island kit, GR w/frpic, FFL, 2BR, 2BA, 2 car att garage, C/A, Sprinklers & deck. Beautiful quiet setting (T70WES) \$178,500 248-349-5600</p>
<p>COMMERCE Enjoy a stately 2 story home with everything you need with int designer flair. Custom window treatments, hardwood floor, 4 BR, 2.5 BA, 3 car garage. A great location, a must buy (T23CRO) \$364,999 248-363-1200</p>	<p>WHITE LAKE Fall in love w/ this Writon III, tastefully decorated, fin. daylight LL, step-up MBR suite w/ Jacuzzi, FR w/ plasma TV, 3 car gar. Trex deck, serene setting in prestigious neighborhood. (G96KEN) \$398,000 248-363-1200</p>	<p>HIGHLAND Exceptional 3 BR, 3 BA Ranch on 1/2 + acre. Fin w/o nearly doubles the living space. MBR w/ BA, 2 frpic, w/ hrdw frs 2 + car gar. W/ workshop. Elevated decking w/ lovely views Lk priv (T78TAG) \$240,000 248-363-1200</p>	<p>FENTON TOWNSHIP LAKEFRONT HOME Open floor plan, Florida rm & FR to yard & lake. 4 BR, 2 BA, MBR walk-in closet & jetted tub, updated kitchen, ceramic floor & maple cabinets. 1 yr home warranty. Pre-approval w/offers. (T81POM) \$299,000 248-626-8800</p>	<p>FARMINGTON HILLS Builders/investors: your chance for an approximately 1/2 acre site, backing to creek. 4 bedrooms, 4 baths Home requires renovation. (T46WES) \$274,000 248-626-8800</p>	<p>PLYMOUTH LOCATION! LOCATION! Just a few blocks to downtown & 2 parks. English style colonials. 3 bdrm, 1.5 bath home. Fine molding & hrdwd frs. Beautiful English gardens, & 2 c gar. (T44HAR) \$264,900 734-455-5600</p>	<p>CANTON GORGEOUS CONDO OVERLOOKING PARK Built in 2002 w/2 bdrms, 2 baths, vaulted ceiling, GR, balcony, hrdwd frs, open kit w/island, all appls, DR, upgrades, CA & att garage w/storage. (T68CON) \$189,900 734-455-5600</p>	<p>NORTHVILLE Open floor plan, wrap around deck off kit, fin LL w/ O has FR w/gas frpic, rec rm, BA & kit. Dual entrances to LL (in-law prt entry), granite T/O, 3 frpics, 3.5 car gar, paver patio. (T10MER) \$829,500 248-349-5600</p>	<p>SOUTHFIELD Spacious home on a large country approx 1 acre lot. Newer wndws, furn, A/C, HWH & ductwork. Move in & enjoy. The work's already been done. Plant your garden now. (T45LEE) \$159,900 248-349-5600</p>

MICHIGAN'S NUMBER ONE CENTURY 21® FIRM



View Every Home in the Multiple Listing Service at
Century21Town-Country.com

Preview Hundreds of Open Houses Throughout the Week at
TCopens.com

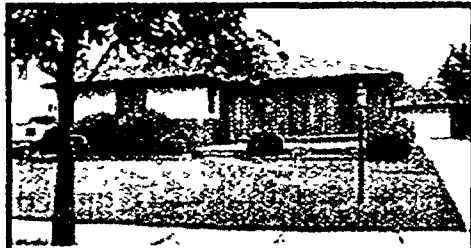

DEARBORN HGTS
 SPACIOUS BRICK RANCH Wonderful 4 bdrm, 3 full bath ranch with fin bsmt, family rm with fireplace, newer furnace and windows. 2 car garage in nice yard with patio.
 T87BRO \$224,500 734-455-5600



PLYMOUTH
 POSSIBILITIES ARE ENDLESS in this 3 bdrm downtown Plymouth bungalow offering updated window, vinyl siding, roof, furn, A/C & freshly painted. Bsmt, hrdwd flrs, & eat-in kit.
 T001RV \$199,900 734-455-5600



SUMPTER TWP
 ENJOY SUNRISE & SUNSETS from your wrap around deck overlooking a gorgeous fenced yard. Many updates including kit w/oak cabinets, roof, windows and so much more.
 T18LOH \$184,852 734-455-5600



SOUTHFIELD
 ELEGANCE AT ITS BEST. Stunning 3 bdrm, 2 bath ranch offers 2 way frplc, high ceilings, hrdwd flrs, custom lighting, prof décor & landscaping, fin bsmt & 2 car att gar.
 T68MON \$335,000 734-455-5600



VAN BUREN
 ATTENTION TO DETAILS. 4 bdrm, 2.5 bath colonial w/high ceilings, crown molding, maple cabs T/O, & hrdwd flrs. Mstr ste w/cath ceilings, 3 car att gar, bsmt w/daylight windows.
 T91PON \$319,900 734-455-5600



CANTON
 FREEDOM FROM THE CITY. 3 bdrm, 1 full & 2 half bath custom ranch on approx 1 acre. Open flr plan, great room sizes, fin bsmt, frplc in liv rm, & heated workshop in 2 car garage.
 T88DIO \$229,800 734-455-5600



PLYMOUTH
 EXCEPTIONAL BUNGALOW. Beautifully updated w/coved ceiling, hrdwd flr, lg kit, bsmt, & gar. Newer windows, furnace, deck, driveway, paint & carpet. Nothing has been ignored.
 T64PAC \$239,900 734-455-5600

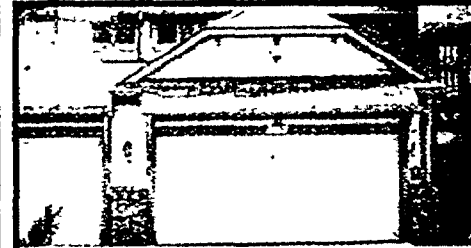

CANTON
 RELAX ON YOUR DECK. Enjoy lovely wooded setting for this 3 BR, 2.5 BA, 2 story condo w/2 car att gar, bsmt, custom window treatment & newer carpet T/O, master suite w/bath.
 T97SAR \$199,900 734-455-5600



PLYMOUTH
 LOCATED IN DOWNTOWN PLYMOUTH. 2 bdrm, 2 bath ground floor condo has it all, large rooms, gas frplc in lg LR, heated att gar with elevator to all flrs. Lg kit w/appls opens to DR.
 T77DEE \$215,900 734-455-5600



DEARBORN
 LIVE THE ENCHANTED LIFE. Gorgeous 5 BR, 4.5 BA remodeled & expanded colonial sitting on approx .5 acres in the city. 2 car att gar, fin bsmt, spacious kit, LR & FR both w/ frplcs.
 T3RIDG \$585,000 734-455-5600



SCIO TWP
 STUNNING CONTEMPORARY sitting on a prime lot in great location w/3 BRs, 2.5 Bas, open floor plan, kit to GR w/frplc, mstr suite has WIC & full bath. Enjoy the lovely pond in back.
 T10VER \$279,000 734-455-5600



CANTON
 DETACHED LUXURY CONDO. 1st flr master suite, elegant foyer leading to great room, dining room & eat-in kit, 3 bdrm, 2.5 bath, 2 car att gar & bsmt. Great deck off back.
 T54VIS \$274,900 734-455-5600



CANTON
 ABSOLUTELY BEAUTIFUL 3 BR, 2 BA ranch w/ tons of updates, plus newer landscaping, Florida room to deck, fin bsmt w/bar, 1st flr laundry & a 2 car att garage. This one won't last.
 T08PRE \$231,900 734-455-5600



NOVI
 EVERYTHING IS BEAUTIFUL 4 BR, 3.5 BA colonial w/2 story foyer, library has French doors, maple & granite kit, 2 car att gar, prof fin bsmt, frplc in GR, din rm off of liv rm & more.
 T84FUL \$399,999 734-455-5600



PLYMOUTH
 CRAFTSMAN HOME 3 BR, 1.5 BA home w/all org trim & woodwork in orig state. Great flr plan w/hrdwd flrs, LR w/brick frplc & wonderful blt-ins T/O & many updates.
 T10MIL \$324,900 734-455-5600



PLYMOUTH
 1924 CRAFTSMAN HOME has vintage woodwork, leaded glass drs & hrdwd flrs, LR w/ blt-in bookcases surround gas frplc, updated kit, newer wood windows, furn, fin LL.
 T43MIL \$238,500 734-455-5600



CANTON
 SPACIOUS RANCH CONDO. Approx 1730 sq ft 2 BR, 2 BA upper unit w/open flr plan, lg kit overlooking brkfst area, mstr w/glamor bath, att gar, huge private balcony, & den w/french drs.
 T34CON \$199,900 734-455-5600

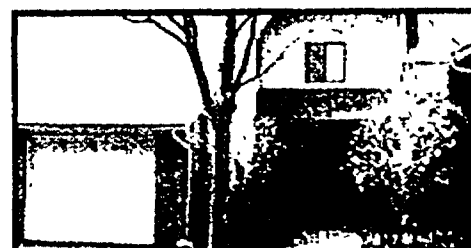

PLYMOUTH
 WONDERFUL CONDO LIVING. This great 2 bdrm, 3.5 bath 2 story condo nestled in a well sought after area only minute from downtown & park. Fin LL w/whirlpool spa + view of pond.
 T11COL \$214,900 734-455-5600

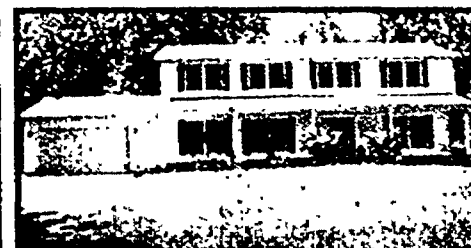

BRIGHTON
 WOODED VIEW. Escape to serene 4 BR, 2.5 BA home. W/O bsmt, pond w/fountain, lg mstr suite, 2nd flr laundry, formal DR, FR w/stone frplc, deck, all appls. & WIC.
 T30PEA \$388,500 734-455-5600



CANTON
 WELCOME HOME. This charming 4 bdrm, 2.5 bath quad has updates galore: newer maint free exterior, vinyl windows, & more. Patio & tiered deck, 2 car att gar & bsmt.
 T02HAR \$234,995 734-455-5600

MICHIGAN'S NUMBER ONE CENTURY 21® FIRM



"MILES
AHEAD OF THE
COMPETITION -
ONE YARD AT A
TIME!"

REMERICA



HOMETOWN III

(734) 459-9898

6231 N. Canton Center Road • Suite 106 • Canton



RemericaHometown3.com



CANTON



Well maintained colonial w/4 lge bedrooms & lots of closet space. Spacious kitchen w/plenty of cabinets & counter space. Formal LR & DR, family rm w/cozy fireplace, and large deck in back for enjoyment. \$249,900 (3964-0)
Call Remerica Hometown III 734-459-9898

ESTATE SALE



Very nice 3 Bedroom Bungalow. 1,000 Sq ft, Living room w/faux fireplace. Hardwood floors, great starter home or investment property. Only \$70,000 (4013-0)
Call Remerica Hometown III 734-459-9898

CANTON



Like new 4 BR Colonial, 2.5 bath home on premium lot backing to pond. Lg brick paver patio, gorgeous 2-story foyer, hrdwd flrs, neutral décor T/O, luxurious mstr ste and bath. Beautifully landscaped and very clean. \$279,900 (3949-0)
Call Remerica Hometown III

WESTLAND



Nice brick 3 BR ranch w/covered patio and huge 2.5 car garage. Newer roof, vinyl siding on home and garage, & door opener C/A, vinyl windows, carpet, partially finished bsmt, & copper plumbing \$139,789 (3978-0)
Call Remerica Hometown III

CANTON



Spectacular cape cod w/open floor plan. 4 BR, 3.5 baths, foyer w/balcony overlooks great rm w/cathedral ceilings & gorgeous fireplace. Gourmet kitchen offers lg center island & plenty of cabinets. Finished bsmt w/lg bar for entertaining \$439,900 (4130-0)
Call Remerica Hometown III 734-459-9898

FARMINGTON HILLS



Stunning brick tudor on premium corner double lot! Privacy w/beautiful view from deck and paved patio, inc. the hot tub! 5 BR's, 3.5 baths, neutral décor, ceramic tile in foyer & baths. Professionally finished bsmt, newly updated kitchen, new carpet & more \$359,555 (4133-0)
Call Remerica Hometown III 734-459-9898

CANTON

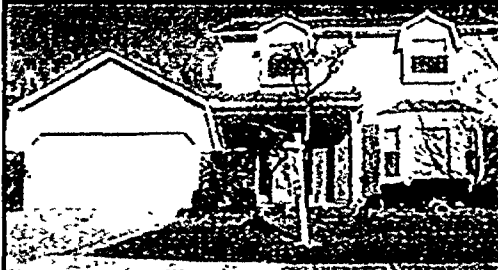

Beautiful colonial w/3 Bedrooms. New kitchen, inc. SS dishwasher, stove & micro. Ceramic baths, foyer, & kitchen. Lge FR w/fireplace & door to patio. Lge mstr w/double doors & bath. New furnace, C/A, roof, gutters, windows & more \$225,000 (3958-0)
Call Remerica Hometown III 734-459-9898

CANTON



Sharp brick cape cod with open floor plan. 4 BR's, 2.5 baths, huge great rm w/vaulted ceilings, nat. fireplace & 2 doorways that exit to a 2 ber deck & fenced yard. Spacious kitchen w/breakfast area & bay window. First flr mstr BR & laundry \$229,900 (4096-0)
Call Remerica Hometown III 734-459-9898

CANTON



Gorgeous elevated brick colonial w/4 BR, 2.5 baths, & almost 3 car side entry garage. Custom features: crown moldings T/O, wainscoting in form. DR, custom window treatments, neutral carpet & paint, raised panel kitchen cabinets. Too much to list! \$369,900 (4027-0)
Call Remerica Hometown III 734-459-9898

CANTON



Brick beauty on premium lot in desirable Royal Point West. Gorgeous kitchen & lge sitting area w/2 doorways, 2-sided marble FP in fam. Rm & breakfast rm. Oak flrs in foyer, kitchen & lav. Mstr BR w/jetted tub and WC. \$427,000 (4111-0)
Call Remerica Hometown III 734-459-9898

5 ACRES



Great 3 Bedroom ranch with attached 2 car garage and a pole barn! Great wooded area with nature trails throughout the 5 acres. Large country kitchen, and over 1,200 sq ft. First floor laundry too \$204,900 (4058-0)
Call Remerica Hometown III 734-459-9898

CANTON



Well maintained brick ranch w/updates. New roof, windows, sump pump, pergo floors in great room, finished bsmt w/glass block windows & 2 rooms. Beautiful maple kitchen cabinets, vaulted ceilings, large deck & fenced yard \$199,900 (3926-0)
Call Remerica Hometown III 734-459-9898

CANTON



Great 4 BR colonial situated in premier golf course community. Walking distance to Pheasant Run & the Summit. Large open fam. Rm w/gas fireplace, spacious mstr BR w/jetted tub, 3 car heated garage w/220V, paver walkway leading to lg deck. \$389,900 (4114-0)
Call Remerica Hometown III 734-459-9898

PLYMOUTH TOWNSHIP



Elegant Robert Jones built home w/private wooded lot. Over 4,800 sq ft of luxury living. Maple flrs on 1st flr, lg island kitchen w/Ann Sachs ceramic tile, granite flrs in 1/2 bath, butlers pantry, formal DR, prof. finished walk-out bsmt. Inc. heated pool! \$745,000 (3952-0)
Call Remerica Hometown III 734-459-9898

CANTON



Country living still near the new IKEA store! Little doll house on over an half acre. Newer kitchen, furnace, A/C, roof, some windows, carpet, and updated bath. Huge garden area and lots of yard! Only \$146,900 (4097-0)
Call Today! Remerica Hometown III 734-459-9898

LIVONIA



Spacious ranch with 4 BR, & 1.5 baths. Kitchen is huge and has been updated w/oak cabinets & tile floor. Mstr bedroom with door that leads to deck and hot tub. Fenced back yard, 1st flr laundry, new furnace, HWY vinyl windows, berber carpet & more \$139,900 (3974-0)
Call Remerica Hometown III 734-459-9898

CANTON



Great home with 4 good sized bedrooms. Over 2,500 sq ft colonial. New oak kitchen w/corrian counter tops, new roof, siding, gutters, pergo flooring, carpet, furnace & A/C. Close walk to schools, club house w/pool & tennis courts in Sub. Just move in! \$299,900 (4049-0)
Call Remerica Hometown III 734-459-9898

FARMINGTON HILLS



Custom built in 2001 on over 1 acre. 3 Car garage, 4,000 sq ft w/2,000 additional sq ft in WOLL. Fine detail w/Venetian plaster paint, marble flooring. Fpic in mstr suite, granite & cherry wood kitchen! \$799,000 (DM-3969)
Call Denise McGilgan 734-564-4310

CANTON



Wooded lot, over 3,200 sq ft, 4 bedrooms & bonus room over garage. Huge granite & maple kitchen w/Jenn-Aire appliances. Heated in-ground pool too! Plymouth/Canton Schools. \$399,999 (DM-3962)
Call Denise McGilgan 734-564-4310

GARDEN CITY

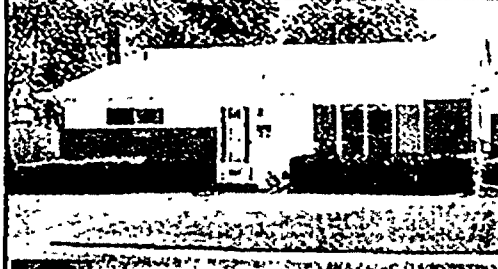

Great open floor plan with massive LR & cathedral ceiling, finished walkout basement. Newer roof, vinyl windows, HWY, tastefully decorated, central air and nice landscaping. 3 BR's and 1.5 baths, 2 car garage \$162,900 (DT-4123)
Call Deborah Teague 734-748-8098

HOMES SOLD

These are the area residential real estate closings recorded the weeks of Feb. 6-10, 2006, at the Wayne County Register of Deeds office, plus some from Oakland County. Listed below are cities, addresses, and sales prices.

City	Address	Sale Price	City	Address	Sale Price	City	Address	Sale Price	
Canton	7777 Alton St	\$181,000	Novi	9886 Milburn St	\$161,000	Westland	26648 Five Mile Rd	\$115,000	
	46159 Bartlett Dr	\$244,000		29813 Richland St	\$162,000		17441 Beech Daly Rd	\$114,000	
	4001 Berkeley Ave	\$152,000		39344 Ross St	\$225,000		19301 Delaware Ave	\$172,000	
	48344 Castleside Dr	\$448,000		14645 Stonehouse Ave	\$173,000		14241 Garfield	\$163,000	
	1605 Commodore Cir	\$210,000		8958 Virginia St	\$164,000		18271 Gaylord	\$131,000	
	454 Cornell St	\$268,000		29455 W Chicago St	\$101,000		26606 Glendale	\$161,000	
	1561 Glengarry Blvd	\$350,000		9906 Woodring St	\$113,000		9145 Grayfield	\$205,000	
	48791 Greenwich Cir	\$370,000		16723 Woodside St	\$255,000		19996 Kinloch	\$85,000	
	3959 Hunters Cir E	\$147,000		16812 Woodside St	\$220,000		18402 Lennane	\$117,000	
	4358 Hunters Cir W	\$147,000		Plymouth	49345 Albatross Dr		\$550,000	9409 Louis	\$177,000
	39715 John Dr	\$178,000			43025 Ashbury Dr		\$465,000	11301 Marion	\$123,000
	41957 Metaline Dr	\$265,000			24658 Bashian Dr		\$144,000	24576 Orangelawn	\$161,000
	7075 N Beck Rd	\$180,000			41611 Blair Dr		\$190,000	9657 Rockland	\$184,000
	2230 N Woods Ct	\$295,000			305 Duana St		\$260,000	14050 Salem	\$168,000
	8436 Newbury Ct N	\$196,000			22745 Foxmoor Dr		\$415,000	14106 Salem	\$162,000
3077 River Meadow Cir	\$241,000	24984 Hadlock Dr	\$912,000		14144 Sarasota	\$155,000			
48283 Roundstone Ct	\$153,000	24381 Holyoke Ln	\$344,000		25929 Student	\$142,000			
45037 Seabrook Dr	\$350,000	40788 Lenox Park Dr	\$299,000		17603 Wakenden	\$158,000			
51182 Sleepy Hollow Ln	\$268,000	22320 Miller Road	\$260,000		20469 Wakenden	\$119,000			
41366 Southwind Dr	\$120,000	22454 Norfolk Ct	\$575,000		15349 Woodbine	\$162,000			
46448 Spinning Wheel Dr	\$235,000	30309 Pennington Ln	\$509,000		8906 Wormer	\$135,000			
48699 Stonebriar Dr	\$58,000	25560 Portico Ln	\$237,000		Farmington	6298 Balmoral Ct	\$166,000		
48757 Stonebriar Dr	\$58,000	24525 Queens Pointe	\$220,000			34329 Barton St	\$168,000		
2986 Tall Oak Ln	\$330,000	1155 S Lake Dr	\$83,000			36731 Canyon Dr	\$222,000		
42137 Trent Dr	\$200,000	24757 Upland HI	\$214,000	34159 Decatur Ct		\$45,000			
44515 Twyckingham Ln	\$217,000	42931 W 13 Mile Rd	\$265,000	34159 Decatur Ct		\$125,000			
Farmington Hills	21595 Birchwood St	\$145,000	43152 Westchester Ct	\$430,000		2247 Delton Ct	\$94,000		
	30251 Essex Dr	\$325,000	Redford	725 Arthur St		\$244,000	32125 Genessee St	\$96,000	
	32100 Grand River Ave	\$115,000		40990 E Ann Arbor Tri		\$166,000	32129 Genessee St	\$88,000	
	23324 Hillview Ct	\$310,000		49074 Fox Dr N		\$380,000	204 Marigold Cir	\$144,000	
				467 Irvin St		\$248,000	6617 N Wildwood St	\$150,000	
		13355 Karl Dr		\$376,000		259 S Carlson St	\$165,000		
Livonia	33853 Eight Mile Rd	\$118,000	1655 Lexington St	\$295,000		1941 S Christine	\$118,000		
	12073 Arcola St	\$135,000	11242 N Haggerty Rd	\$198,000		1559 S Sutton St	\$177,000		
	12319 Arcola St	\$141,000	9294 Northern Ave	\$299,000		35646 Thames St	\$125,000		
	14610 Auburndale St	\$185,000	11849 Sycamore Dr	\$130,000		1694 Tulip Ln	\$187,000		
	34591 Beacon St	\$159,000	Garden City	26406 Five Mile Rd	\$165,000	1759 Tulip Ln	\$182,000		
	9830 Blackburn St	\$180,000		28442 Beechwood St	\$149,000	2281 W Miller Cir	\$195,000		
	9830 Blackburn St	\$180,000		5707 Cardwell St	\$167,000	2244 Wilshire St	\$164,000		
	29728 Buckingham St	\$200,000		6449 Elizabeth St	\$149,000				
	9268 Butwell St	\$202,000		30550 Marquette St	\$190,000				
	12026 Chase Blvd	\$225,000							
	31300 Dorais St	\$200,000							
	9981 E Clements Cir	\$167,000							
	14965 Fairway St	\$184,000							
	18456 Gillman St	\$150,000							
	19042 Irving St	\$149,000							
35912 Joy Rd	\$186,000								
29645 Lori St	\$180,000								

The RESERVE AT NORTHVILLE RIDGE

Northville homes from the \$300s

**UP TO
\$20,000
IN SAVINGS ON
SELECT HOMES!***

- Acclaimed Northville Schools • Close to I-275, I-96 and M-14 • Private clubhouse, pool and exercise room included • Walking/biking paths and separate sidewalks
- Minutes from historic downtown Northville • Built by 2005 "Hall of Fame" premiere building family
- * Limited time offer

248.380.1500
16959 Carriage Way, Northville, MI 48167
www.unilandcorp.com

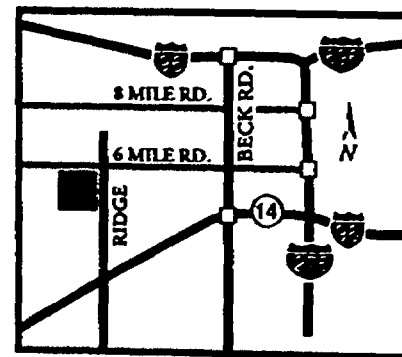

At the southwest corner of
Ridge and 6 Mile



THREE GENERATIONS OF BUILDING EXCELLENCE

Keeping roofs in top shape

(NAPSI) — Don't get caught streaking — on your roof, that is. Green and black algae can be a major headache for homeowners. Algae not only make a roof look bad, but will likely shorten its life as well.

Commonly called fungus, algae create unsightly dark brown, green or black streaking on shingles. Sometimes these streaks are mistaken for soot, dirt, moss or tree droppings. While regions with sustained humidity and moisture tend to be most at risk, people who live in all parts of the nation with roofs made from all sorts of materials are susceptible to moss and algae accumulation. In fact, all algae need to survive and thrive are air, water and a food source.

Methods of cleaning can cause unneeded wear and tear to your shingles. Fortunately, some of the latest

shingles come in an algae-resistant version, alleviating unsightly streak and maintenance hassles. For example, many of CertainTeed's asphalt shingles are available with the algae-resistant Streak-Fighter™ feature. The company indicates that a specific raw material protects its Streak-Fighter shingles from the streaking and discoloration of airborne algae. Look for it on the company's wood-shake and slate-style shingles.

According to Marcia Hannah of CertainTeed, streaks can be a thing of the past. "The addition of roofing granules containing copper helps to alleviate the problem of unsightly streaks. This is good news for home maintenance and good news for real estate values."

For more information, visit www.cerainteed.com or call (800) 782-8777.

Visit hometownlife.com for daily updates of news, sports and photos

FEATURE HOMES

BRIGHTON TWP

Hillsborough Estate Sub. New subdivision near Kensington Metro Park offering huge price credits on select parcels. 72 parcels available - all 3/4+ acre parcels. Buy now - build later. Located off Commerce Rd - 1 mile W. of Pleasant Valley. Prices start at \$69,950. MLS# 25043086.
Call Christine Migliore/Boonie Lane (810) 923-0906
MICHIGAN GROUP www.michigangroup.com

HOWELL

COUNTY FARM ROAD RANCH! Move in & enjoy the summer! 1,426 SF, 3 BDs, 2 BAs, open flr plan w/large rooms. Partially finished basement for rec or family room. A/C, fenced yard for kids or pets. Beautiful landscaping. Close to Howell! Won't last! \$200,000. MLS# 2609454
Call Theresa Elgereia (517) 548-2858
MITCH HARRIS BUILDING CO. www.mitchharris.net

WHITE LAKE

Beautiful custom home on wooded 1.74-acre lot w/swim & fish privileges on private lake. Living rm w/gas FP. Hearth rm opens to gourmet kitchen w/stainless appliances. Full finished basement w/wet bar. Extensive decking & landscaping. Walked Lake Schools. \$399,900. MLS# 26103288
Call Team Callan (810) 623-7876
RE/MAX PLATINUM www.TeamCallan.com

ADVERTISE WITH FEATURE HOMES

For more information, contact your sales representative.

THE MICHIGAN GROUP REALTORS
SERVING ALL OF SOUTHEAST MICHIGAN

<p style="font-size: 0.8em;">BY APPOINTMENT ONLY • PINECREEK Lease or Buy! Duplex - each unit has 3 bedrooms, 2 baths, 1st floor laundry & master all appliances! Short term & pets ok! MLS #25138541 Julie Cremona (734) 216-1956 \$1,150 per month</p>	<p style="font-size: 0.8em;">BY APPOINTMENT ONLY • MILFORD Best buy in Hartland! Quiet two-2 acre custom w/look homesites with pond view. Home & Schools. Milford mailing. Livingston County taxes! Good parks, great sunsets! MLS #26082678 & 26082642 Tricia Gray (248) 496-4177 \$69,900 each parcel</p>	<p style="font-size: 0.8em;">BY APPOINTMENT ONLY • HOWELL 2 BR, 2 BA. Best priced condo in complex. Own entry level ranch style w/attached garage. 9 ft ceiling, handicap accessible. All appliances included. Shopping & expressway nearby. MLS #26040723 Mary M. Novak (248) 437-5000 x105 \$134,500</p>	<p style="font-size: 0.8em;">BY APPOINTMENT ONLY • SOUTH LYON 3 BR, 1 BA plus 2 car garage w/workshop & shed. All the work has been done! Updated kitchen, roof, furnace, A/C and electric. Lrg fenced yard is ready for family BBQ's. Within walking distance to Elementary school & downtown South Lyon. Perfect for 1st time home buyer! MLS #26087020 Mary M. Novak (248) 437-5000 x105 \$167,000</p>
<p style="font-size: 0.8em;">BY APPOINTMENT ONLY • SOUTH LYON 2.3 BR, 1 BA, 1 acre landscaped to the max! Looks like a botanical garden at U of M complete with water fall pond. Huge LR, lg country kit. Open airy & light. Easy living covered deck wired for music. Mechanics dream garage has sep. workshop. MLS #26076080 Laurie Forrest (248) 789-2724 \$179,900</p>	<p style="font-size: 0.8em;">BY APPOINTMENT ONLY • HOWELL 4 BR, 3 BA. Welcome to your new home! This Cape Cod sits on 2 acres. Pride of ownership shows through. Main suite on main level w/garden tub. Living rm offers a custom stone FP & LL is newly finished (2005). At 2 car garage plus det. 2+ car lg covered front porch & deck off the kitchen too! All appliances included. MLS #26092124 Mary M. Novak (248) 437-5000 x105 \$229,000</p>	<p style="font-size: 0.8em;">BY APPOINTMENT ONLY • HOWELL 4 BR, 3 BA. Totally remodeled! 1-1/4 acre private road. 2300 sq. ft., 3 full baths, 2 fireplaces. New custom maple kitchen! Front walked courtyard with brick pavers great for enjoying a barbecue! MLS #26062431 Ken Ives (810) 444-4530 \$240,000</p>	<p style="font-size: 0.8em;">BY APPOINTMENT ONLY • WHITMORE LAKE 4 BR, 2.5 BA. Best priced home in sub located 10 minutes to Ann Arbor. Featuring private tree backyard attached 2 car garage. Pergo flooring in living room, basement. 2 story entry foyer. Home Warranty. MLS #26092431 Nick Natoli (810) 844-2278 \$237,450</p>
<p style="font-size: 0.8em;">BY APPOINTMENT ONLY • BRIGHTON 4 BR, 2 BA. Enjoy all sports like living in this all brick Cape Cod style home. Open floor plan is perfect for entertaining! MLS #26068729 Mary M. Novak (248) 437-5000 x105 \$350,000</p>	<p style="font-size: 0.8em;">BY APPOINTMENT ONLY • DEARBORN 4 BR, 3 BA. Absolutely beautiful inside & out describes the brick Colonial sitting on a corner lot! Recently updated & well maintained home offers the new owner a master suite, entry flr w/ kitchen, 3 FPs, fire, built in much more! Walk to Leavood Park & Divine Child. Pride of ownership shows! All appl. included. MLS #26072895 Mary M. Novak (248) 437-5000 x105 \$369,500</p>	<p style="font-size: 0.8em;">BY APPOINTMENT ONLY • MILFORD 4 BR, 4 BA, 3,500 sq. ft. custom farmette, 5.77 acres. Large kitchen and impressive master suite 1,100+ sq. ft. custom lower level, in-ground pool, horse barn! Too much to mention - MUST SEE! MLS #26082598 Tricia Gray (248) 496-4177 \$625,000</p>	<p style="font-size: 0.8em;">BY APPOINTMENT ONLY • BRIGHTON Dutchmen Farms Subdivision New construction - model and 3 homes available. Beautiful floor plans, extensive trim, crown molding, ceramic tile, hardwood floor in foyers and dining rms. Vacant lots available - some walkouts. Bring your plans or pick from ours. Builder's Progressive Homes Inc. MLS #26029101, 25181423, 25181415, 25079192 Kandis Thompson (810) 844-2288</p>

(810) 227-4600
(810) 714-7300
(248) 437-5000

6870 GRAND RIVER • BRIGHTON
3160 SILVER LAKE RD. • FENTON
22180 PONTIAC TRAIL • SOUTH LYON

The Michigan Group Inc - Livingston Realtors will not be responsible or liable for misinformation, misprint, typographical errors, etc. which might appear in advertising.

www.hometownlife.com

•OBSERVER & ECCENTRIC • MIRROR • HOMETOWN WEEKLIES | Thursday, June 29, 2006 • (West) 17

**Picket fences.
Chimneys.
Land.**



It's easy to find all of the above and more in
Hometownlife.com REAL ESTATE and online at *hometownlife.com*.
You'll discover a huge variety of homes and one of them is just waiting for you.

HOMETOWN*life.com*

WEEKLY REAL ESTATE

Part of The Observer & Eccentric Newspapers, HomeTown Weekly Newspapers and Mirror Newspapers

REAL ESTATE BRIEFS

Homebuyer's Seminar

There will be free a Homebuyer's Seminar 11 to 3 p.m. Saturday, July 8, at Century 21 Today, one block west of Beech Daly at 26000 Five Mile in Redford. There will be door prizes and giveaways. Speakers include: real estate attorney, title company, mortgage lender, home inspector, certified public accountant and others.

Attendees will get answers to these questions: Why do buyers receive free buyer agency representation and why do they need it? What is the difference between a private inspection and a required municipal inspection? How much home can I afford and how do I protect my credit score while shopping for a loan? How can buying a home actually save me money? How do I get seller concessions to cover my costs?

For details, contact Mel Haggood at (313) 538-2000 or e-mail pisanhart@aol.com.

Shore Mortgage

Shore Mortgage will offer a free Homebuyers/FICO score seminar 7-9 p.m. every third Monday through August. Seminars will take place at Shore Mortgage, 1741 N. Canton Center

Road, Canton. For reservations or more information, call (248) 433-3300.

Builders Institute

Henry Ford Community College in cooperation with the Oakland Builders Institute will offer a builder's pre-license class to help you pass the Michigan state builder's examination. The 16-hour seminar will be 6-10 p.m. Tuesday/Thursday, July 11, 13, 18 and 20, at Henry Ford Community College, Dearborn Heights campus, 22586 Ann Arbor Trail.

The course is for those who want to subcontract construction of their own homes, real estate investors and developers and building tradespeople who want to work legally in Michigan. Cost is \$189 for residents plus \$20 for textbook and sample questions, \$208 for nonresidents plus \$20 for textbook and questions. Pre-registration with payment is required by Friday, July 7, to Henry Ford Community College. To register, call (313) 317-1500.

Building Industry Association

The Building Industry Association of Southeastern Michigan will present:

■ Its Macomb County Golf Spectacular 11 a.m. to 6 p.m. Wednesday, July 12, at Cherry Creek

Golf Club, 52000 Cherry Creek Drive (24 Mile and Van Dyke), Shelby Township. Fees, including 18 holes of golf (spikeless course), cart, lunch, refreshments, dinner and golf competitions are \$145 for BIA and Apartment Association of Michigan members, guests and nonmembers; \$60 for dinner only, \$200 for a hole sponsorship and \$250 for a hole sponsorship with dinner. For registration information, call (248) 862-1033.

■ A development site tour of Partridge Creek in Clinton Township 10 a.m. to 2 p.m. Wednesday, Aug. 2. The tour begins at Burton Katzman, 30100 Telegraph, between 12 Mile and 13 Mile in Bingham Farms. Parking is available on the south side, adjacent to the boundary of Bingham Office Park and Fitness USA. The community will feature 360 single family homes, 40 models and already constructed homes, 600 condo units, senior housing and a 600,000-square-foot lifestyle center. The community is developed by Taubman Group and Trinity Land Development. Registration fees, including lunch, are \$40 for BIA members and \$60 for nonmember building industry professionals. For information, call (248) 862-1033.

■ A Certified Graduate Builder Series seminar on "Introduction to Business Management" 8 a.m. to 3 p.m. Thursday, Aug. 3, at BIA headquarters, 30375 Northwestern Highway, Suite 100 in Farmington Hills. It will be taught by Chuck Breidenstein of Builders Professional Services. The seminar introduces builders and remodelers who are interested in improving their bottom line to systematic planning processes used by industry experts. It focuses on basic management tools such as developing a business plan and implementing control procedures to monitor efficiency and profitability. Fees are \$140 for Remodelers Council members and \$160 for BIA members and guests. To register, call (248) 862-1033.

■ Apartment Association of Michigan will sponsor a technology seminar, "Electronic Rent Collection," 8:30-10:30 a.m. Thursday, Aug. 3, at AAM headquarters, 30375 Northwestern Highway, Suite 100 in Farmington Hills. Kirk McNeil and Greg Fish of Biznet Internet Solutions will demonstrate the benefits of an e-payment program. Fees, including continental breakfast, are \$10 for

PLEASE SEE BRIEFS, 20

Get yourself closer to nature...water...wilderness!

Northwestern
Michigan Properties



LEELANAU COUNTY
Perfect off water location in Leland. Just a block from the post office and 2 block to the North Beach. Large beautifully landscaped sloping yard consisting of 2 village lots. Large deck and patio area. Large open living area with wood stove and many windows. \$399,000 (1/4/7/99)

COLDWELL BANKER
SCHMIDT REALTORS - LELAND

Contact:
MARK CARLSON
231-256-9836



RIFLE LAKE
LOTS 8 & 9

Last 2 lots on all sports lake, head waters of the Rifle River. This is the perfect spot for your new home or cottage!
Lot 8 - \$110,000 • Lot 9 - \$103,500
Call Jackie Proctor
517-902-6090
ADVANCED REAL ESTATE
9301 Tecumseh Clinton Road • Tecumseh, MI 49286



LAKE HURON COTTAGE
Beautiful Sunrises, Clear Water, Bald Eagles.... Motivated Seller!
6000 Lakeshore, Palms, MI (north of Lexington)

Lake Huron Cottage only 2 hour drive and not on I-75. 5 miles from Minden City State recreation area. 1200 sq. ft., 3 bedroom cottage with fireplace, cedar walls, terraced landscaping and fire pit. Fantastic flat, deep, sandy beach. Taxes less than 3K per year.

Call now! You will not find a better deal than this at \$219,000
248-259-4264

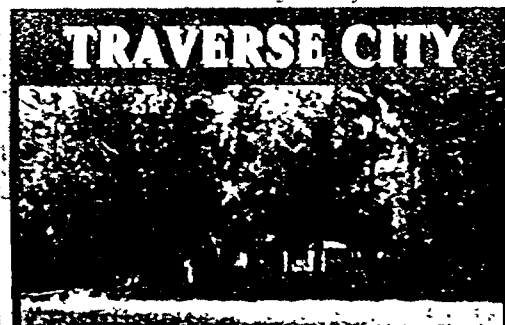

TRAVERSE CITY
WATERFRONT

The ULTIMATE SETTING on pristine Long Lake. This impeccable 3 bedroom, 1 1/2 bath home has over 300 feet of hard sand bottom and water views from almost every window. Priced below appraised value at \$799,000.

RICK STEIN
213-941-4500
RE/MAX BAYSHORE PROPERTIES
500 SOUTH UNION STREET • TRAVERSE CITY, MI 49684

Check the Classified sections of these fine community newspapers for more property listings:

Birmingham Eccentric
Canton Observer
Farmington Observer
Garden City Observer
Livonia Observer
Milford Times
Northville Record
Novi News
Plymouth Observer
Rochester Eccentric
Royal Oak and Clawson Mirror
Redford Observer
Southfield Eccentric
South Lyon Herald
Troy Eccentric
West Bloomfield Eccentric
Westland Observer
and on

HOMETOWNlife



WORKERS

FROM PAGE 10

the Gulf Coast.

"Realtors are in an ideal position to work with local officials, nonprofit housing groups, and the business community to draw attention to this growing issue and help create programs that have a broad impact," said Stevens.

Co-sponsored by the Delaware Association of Realtors, the District of Columbia Association of Realtors, the Maryland Association of Realtors, the Virginia Association of Realtors and the

West Virginia Association of Realtors, the Mid-Atlantic Regional Summit on Housing Opportunities featured public and private sector housing experts addressing affordability issues confronting the four-state region.

Speakers included Alphonso Jackson, secretary of the U.S. Department of Housing and Urban Development; former HUD Secretary Jack Kemp; Tom Donohue, CEO, U.S. Chamber of Commerce; Mayor Bill Euille, Alexandria, Va.; Councilman Steve Silverman, Montgomery County, Md.; Conrad Egan, National Housing Conference; Rich Parsons, Montgomery County (Md.) Chamber of Commerce; Dr. Steve Fuller, George Mason University; and Realtor leaders from Delaware, the District of Columbia, Maryland, Virginia, and West Virginia.

The National Association of Realtors, "The Voice for Real Estate," is America's largest trade association, representing more than 1.2 million members involved in all aspects of the residential and commercial real estate industries.

BRIEFS

FROM PAGE 19

AAM or BIA members, \$20 for non-members and guests. To register, call (248) 862-1004.

■ BIA's Sales & Marketing Council is sponsoring a real estate continuing education seminar presented by Lori Chumura of Middleton Training. It will be 8:30 a.m. to 3 p.m. Wednesday, Aug. 9, at BIA headquarters, 30375 Northwestern Highway, Suite 100 in Farmington Hills. The course meets the state-mandated six-hour requirement for continuing education. Fees are \$60 for SMC members, \$75 for BIA members and \$90 for guests. For registration information, call (248) 862-1033.

■ A Certified Graduate Remodeler course on "Negotiating" 8 a.m. to 3 p.m. Thursday, Aug. 10, at BIA headquarters, 30375 Northwestern Highway, Suite 100, Farmington Hills. Chuck Breidenstein of Builders Professional Services Group will offer a practical approach to interpersonal problem-solving and suggestions for negotiating. Fees are \$140 for Remodelers Council members, \$160 BIA or Apartment Association of Michigan members, non-members and guests. To register, call (248) 862-1033.

NEW HOMES
FROM THE \$180's

ORCHARD PARK

Coming Soon to Howell

Community Clubhouse • Pool • Soccer Field

To Join The Abbey Homes VIP Priority Purchaser List, visit
www.OrchardParkVIP.com

Or call 514-540-0407

ABBAY HOMES

Where the Living is Easy



Visit hometownlife.com
for daily updates of news,
sports and photos

**COLDWELL
BANKER**
BRIGHTON TOWN & COUNTRY
REAL ESTATE



Everyone's Moving to Livingston County -
The Fastest Growing County In Michigan!

Coldwell Banker Brighton Town & Country Real Estate

BRIGHTON \$193,000.00 3 BR ranch 1+ acres!
Deck, hot tub! Bsmt, 2 car gar. L7989

BRIGHTON \$209,900.00 3 BR, 2.5 bath newer 2
story, 2 car gar. L8017

BRIGHTON \$212,000.00 4 BR, 1.5 baths, 1747
Sq.Ft., 2 car gar. L8045

BRIGHTON \$224,900.00 3 BR, 3 Bath, 1412
Ranch, 2 car gar. L8061

BRIGHTON \$245,000.00 3 BR, 2.5 bath ranch.
Finished walkout, 2 car gar. L8023

BRIGHTON \$249,900.00 4 BR ranch, Office,
workshop, 3 season rm., 2 car gar. L7998

BRIGHTON \$259,900.00 4 BR, 3 Bath Ranch, fin-
ished walkout, lake priv. 2 car gar. L8020

BRIGHTON \$249,900.00 3 BR, 2 1/2 baths, 1.5
story. Living & Dining rm., L8022

BRIGHTON \$264,900.00 4 BR, 2.5 Bath, a/c,
new Construction. L 8062

BRIGHTON \$273,900.00 4 BR Updated, 1st flr
office, laundry, 2 car gar. L7879

BRIGHTON \$315,000.00 4 BR, 3.5 bath, 3000
sq.ft., finished walkout. L8011

BRIGHTON \$321,500.00 4 BR, 2.5 bath, 2 story,
walkout. 2 car gar. L8005

BRIGHTON \$337,777.00 4 BR Newer 2,499 sq.
ft., great location. L7992

HARTLAND \$349,900.00 4 BR, 2.5 bath, gated
community. 2850 sqft. L7997

HARTLAND \$389,900.00 4 BR, gated community,
2580 sq.ft., 3 car gar. L8040

HOWELL \$139,900.00 2 BR, lake view & access.
Docking privileges. L7993

HOWELL \$175,000.00 3 BR ranch, over 1 acre.
Full basement Attached garage. L7987

HOWELL \$194,900.00 4 BR, 2 bath Ranch!
Fireplace, fin. bsmt. Pool, deck! L7982

HOWELL \$225,000.00 3 BR, 1.5 Bath, 1425
Sq.Ft. Sprawling Ranch. L8041

HOWELL \$238,500.00 4 BR, 2.5 bath, 1930 sq ft.
2005 built 2 story. L8016

HOWELL \$244,900.00 4 BR Cape Cod, 1 acre.
1st flr master & laundry. Deck. L7929

HOWELL \$329,000.00 4 BR, 3 Bath, Cape Cod,
5+ acres. 2 car gar. L8014

PINCKNEY \$175,000.00 3 BR, 1.5 bath, base-
ment, deck updates. L8029

PINCKNEY \$286,000.00 4 BR, 2.5 Baths, 2100
sq.ft., 3 car garage. L8027

PINCKNEY \$398,900.00 4 BR on the Golf
course. 3100 sq. ft. 3 car gar. L7885



CANTON - Great location for this 4 bdrm,
2.5 bath colonial offering 2 story foyer w/
hardwood flr, great rm w/vaulted ceiling,
balcony & see-thru frpic to breakfast rm,
elegant master w/large bath & huge 14x8
walk-in-closet + more! \$369,900 (D77Mor)

ROYAL OAK - Fabulous location for this 4
bdrm, 2 bath 1920's charmer w/all the
modern updates! Newer kchn w/light oak
cabs & ceramic floor, roof shingles, copper
plumbing, fum, C/A, vinyl windows + more.
Deep lot with 2 car garage. \$254,900
(L22Phl)

DEARBORN Why rent when you could
own this updated 3 bdrm home in great
condition. New oak kitchen, newer paint,
roof, carpet, windows, doors, sliding &
copper plumbing. Lrg master w/lrg closet
area. Walk to elem school! 1 yr home
warranty! \$119,900 (LOONew)

FARMINGTON HILLS - Charming 3 bdrm
colonial in a great area. Cathedral ceiling in
great rm, family rm w/brick FP, hardwood
floors thru-out, door wall off breakfast nook
to patio & beautiful yard. Updated roof,
siding & windows. All appliances stay!
\$194,900 (L98Dun)



PINCKNEY VILLAGE - Beautifully updated
3 bdrm home on large lot at great value!
Lower level prepped & framed for 2nd full
bath, newer roof '05, H2O heater '05,
furnace '03, newer garage door, interior
freshly painted + more. Great
neighborhood! \$169,900 (D68Ash)

CANTON - Immediate occupancy for this
exquisite contemporary colonial w/4
bdms, 2.5 baths, 1st floor library & sunrm
overlooking spacious deck & private yard.
3 car side entry garage. Great location,
close to new high school! \$448,000
(L94Lab)

NORTHVILLE - Spacious rooms thruout
this gorgeous Northville condo which h
features 3 frpic, 3.5 baths, 19x16 mstr ste
w/20' walk-in-closet, jetted tub, 1st flr
library, 2 car garage, fin'd bsmt &
overlooks golf course setting! \$399,900
(L76Mui)

LIVONIA - Located on the service drive w/
blvd & no thru traffic plus a lrg fenced yard!
Offers 4 bdms, 2.5 baths, updated kchn,
baths, Anderson wndws, roof shingles, fum
& C/A. Fin'd bsmt w/lrg rec rm & 5th bdrm,
Florida rm + more! \$268,900 (L80Fiv)

For information on every home for sale in S.E. Michigan, go to:

www.qualitygmac.com

Quality **GMAC**
Real Estate

(734) 462-3000



That's why you need an area specialist.

810.227.1111

102 E. Grand River - Brighton • www.coldwellbankerbrighton.com



ABSOLUTE AUCTION Sat, July 15th @ 11am
11494 Cedar Bend • Pinckney

LAKEFRONT PROPERTY Tamarack Lake on Chain of Lakes. This beautiful, secluded, year round lakefront property has 2 possibly 3 bdrms., hardwood floors, cathedral ceiling, woodburning fireplace, hot tub, outdoor shower, gazebo, boat dock & much more! Will sell to the last & highest bidder

Terms: \$10,000 down day of sale, balance within 30 days.

ASSIST2SELL • Sellers & Buyers' Realty
Daniel Kapudjija, Auctioneer • 888-461-8188

OE08450023



REAL ESTATE AUCTION Sat, July 15th @ 2:30pm
11360 Sand Hill Road • Grass Lake

Custom ranch w/walk-out finished bsmt., master suite, 3 additional bdrms., 3 full baths, 2 car garage, fireplace, lg. lot. Pole barns, pools, allowed. 20 min. from Ann Arbor Exit 150 off I-94. South to subdivision. Come bid your price!

Clark & Crossing

City of South Lyon
Lots For Sale or Build To Suit

- Sewer/Water • City Services
- 2 Parks/Nature Areas
- Wooded and Walkout Sites

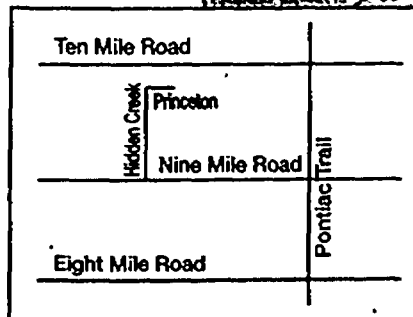

*Pontiac Trail to
9 Mile (W)
to Hidden Creek to
Princeton*



Dan Mulvihill
810-227-8551

OE08449030

RENT

In the **FARMINGTON HILLS AREA**

\$732*

(average for one bedroom)

OWN

at **HILLSIDE FOREST**

\$560**

(actual cost of ownership)



So, why are you still renting?

FARMINGTON HILLS NEWEST CONDOMINIUMS

- 1 & 2 bedroom condominium homes
- Serene natural setting
- Outdoor pool and tennis courts
- Fitness center
- Convenient location
- Extraordinary views
- Priced from \$99,900

GRAND OPENING

For a very limited time receive unit upgrades including:
New Kitchens with Appliances • New Carpet • New Vinyl
in Foyer, Kitchen and Utility • New Brushed Nickel Lighting
Package and Your Choice of Paint!



HILLSIDE FOREST

Sales Center and Decorated Models
30545 Crest Forest, Farmington Hills
East side of Haggerty
(btwn. 13 and 14 Mile Roads)
Hours: Daily 11-6 pm
248.487.2400 or 866.242.3355 toll-free
brgcustomhomes.com

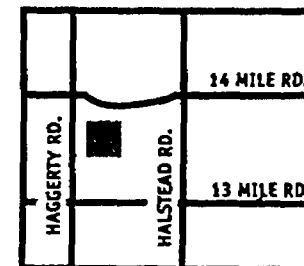

BRG Custom Homes

*Based on the average monthly cost for a one bedroom apartment in the Farmington Hills area, from apartments.com. **Assumes 10% down, excludes association dues and taxes. Total payments starting at \$820/month. All information subject to change at anytime without notice.

**GRAND
OPENING
SPECIAL**
\$2000 of
FREE
upgrades!



LUXURIOUS CONDOMINIUM HOMES FROM \$209,900

New Construction Condos in New Asbury Hill Village

- Ranch or Cape Cod style homes
- Highly acclaimed South Lyon Schools
- Daylight and Walk-out sites
- Gourmet Kitchens with appliances
- Granite Countertops throughout
- Vaulted Ceilings
- Hardwood Floors
- Quick occupancy available
- Close to Expressways
- Near Kensington Metropark

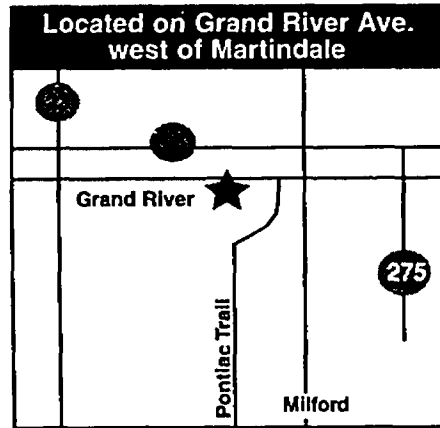

For more information, call:

Jan Raupp
248-981-6348 or
Peter Argenta
248-719-3980

Open Fri., Sat. & Sun. 1-5pm
or by appointment



Replacing lost or destroyed documents

(NAPSI) — Life happens when you're not ready. Hurricanes, tornadoes, fires, floods, landslides, earthquakes — all of these things can come when you're unprepared. That's why it's important to safeguard important documents by storing copies in a safe place away from your home.

What do you do if you need to prove ownership of your property, and you cannot locate your ownership documents? Where can you obtain copies of your deed, deed of trust, warranty deed, or title policy? In order to rebuild or repair your home, you may need to prove ownership.

In most circumstances, your county courthouse will have copies of your property ownership documents, unless the courthouse also was damaged, such as occurred in Louisiana and Mississippi after Hurricane Katrina. Here's how you might be able to track down replacement documentation:

■ When your county courthouse is intact and undamaged, the county clerk can provide, for a fee, certified copies of your deed or mortgage showing that you own your home. If that's not possible, there are other options.

■ Contact your attorney, closing agent or real estate agent to obtain the name of the title company you worked

with. They can put you in touch with the title underwriter that issued your Owner's Title Insurance Policy.

■ Contact your lender to ask if they can provide you with a copy of your mortgage. Your attorney or closing agent might have the name of your lender if you cannot locate it.

Now is a good time to make copies of your important homeownership documents (as well as your personal documents). One method is to scan your documents and save them to a disk or CD-ROM and send it to a trusted counsel, family member or friend who lives in a different part of the country. Another method is to photocopy the documents and store the copies in a bank safe deposit box or home safe. In either case, to prevent likely water damage, seal the disks, CDs or documents in plastic storage bags. Hopefully, you will never have to rely on this information, but it's good to know there are things you can do to prepare for an emergency.

The American Land Title Association has a helpful Disaster Recovery link on its Web site, www.alta.org. Click on the Disaster Recovery logo at the top of the page, and scroll down to the section Special Tips for Homeowners.



Dan & Stuart Elsea

"It's the best time to invest in Michigan."

In the 75 years since our grandfather founded this company, there has rarely been a better combination of low interest rates and a larger inventory of homes, making this year the best time to purchase your home.

BROOK
1895



Johnston & Johnston

The Real Estate One Family of Companies

Real Estate One, Mirco, and Progress are trademarks of Johnston & Johnston, Inc. All other trademarks are the property of their respective owners.



<p>Farmington Hills 1ST FLR RANCH CONDO IN RAMBLEWOOD Private entrance. Well situated in prestigious gated community Short walk to pool. 3 BR. New crpt & kit flr. Att gar MBR w/shower & sunken tub. (26087992) \$193,000 Steve Leibhan 248-851-4100 x405</p>	<p>Brighton Custom home 1.32 acre park like lot. 3BR/2.5BA, great room w/ fireplace, cathedral ceiling, formal dining, out building allowed, low twp taxes. (26041180) \$339,900 Sheryl Schumaker 248-514-1962</p>	<p>Northville BEAUTIFUL COLONIAL IN STEEPLECHASE 1 yr old w/many upgrades. 4 BR, 3.5 BA. 3 car garage. Unfinished w/o bsmt backing to pond. Hrdwd flr. Kit w/ granite counters & cherry cabinets. (26049980) \$800,000 Denise Busser 248-444-7232</p>	<p>Farmington Hills PERFECT RANCH HOME Set on a gorgeous wooded lot. Loaded w/ custom extras. Sunroom, upgraded everything. Huge LR, slate trimmed FP, vaulted ceiling. DR, eat-in kit., beautiful MBR. (26090464) \$309,500 Andy Collins 248-523-2327</p>	<p>Livonia FABULOUS DETACHED CONDO To Die For! Fantastic 2 Bedroom Ranch with 2 1/2 Baths, 2 car attached garage, Main floor laundry and a fireplace too. (26017837) \$200,000 Linda Adkins 734-504-7766</p>	<p>Brighton Lake view! 6030 SF, finished basement has bar, bath & fireplace. Pine Creek amenities. (2171614) \$624,900 Kathleen Bartlett 810-599-9696</p>
<p>Dearborn HOW SWEET IT IS! 2600 Square feet, 4 bedrooms, 2 1/2 baths, 2 fireplaces, hardwood floors, foyer entrance Cape Cod, basement, C/A, attached garage & more (26085651) \$439,900 Linda Adkins 734-504-7766</p>	<p>Livonia VERY NICE 4 BR LIVONIA COLONIAL Close to parks, shopping & golf. Lovely family room w/frplc, updated kitchen w/ oak cabinetry Formal dining room & more (26094322) \$244,000 Carolyn Bailey 313-910-8162</p>	<p>Novi TASTEFULLY DECORATED & IMMACULATE 3 BR, 2.5 BA 1982 built Glenhaven condo. Upgrades & updates t/o Feature sheet in home. Friendly community. Home warranty Don't miss this one! (26077163) \$177,900 Barb Williamson 248-207-1565</p>	<p>Howell Move right in! 3BR/2.5BA condo. Kitchen & dining open to great room w/fireplace. 1st flr Indry. Generous size bdrms, lots of storage, finished basement. (26066242) \$184,900 Sheryl Schumaker 248-514-1962</p>	<p>Farmington WALK TO TOWN 4 BR updated 3000 sqft ranch on private 1/2 acre lot. Cherry kit, new carpet & Pergo flrs, huge deck, full fnshd bsmt, 3.5 car gar, tons of updates. WOW! (26101020) \$449,900 Carol Copping 248-444-8105</p>	<p>Pinckney 95' frontage on all sports lake. stainless steel appliances, brushed nickel lighting, ceramic, 3BR/2BA, big deck priced 50K under appraisal. (26090362) \$249,900 Debbie James 734-231-0097</p>
<p>Novi PRICE PLUNGES!!! Home w/ Northville Schools. 2600 sqft, 4 BR, 3.5 BA. Many expensive features include wood wndws, new furn, newer roof, carpet & driveway. Beautiful inside & out. (26064162) \$349,000 Virginia Donohue 248-974-5012</p>	<p>Northville 2001 BUILT END UNIT IS LIKE NEW 1620 sqft. Many upgrades! Skylights! 2 BR, 2.5 BA White kitchen w/stainless appliances. 1 car garage. Next to woods/stream. Walking distance to downtown. (26031517) \$244,900 Denise Busser 248-444-7232</p>	<p>Livonia AS GOOD AS IT GETS Absolutely Metuculous 2 Bedroom, 2 Bath Contemporary Condo With upgrades throughout. Vaulted Ceilings, Walk-in Closets, Deck & Attached Garage (26046289) \$174,900 Linda Adkins 734-326-2000</p>	<p>Farmington Hills GREAT HOUSE IN GREAT SUB Features new first floor master suite. Farmington Hills location convenient to all freeways. This one won't last long! (26044243) \$324,900 Brenda Zack 248-939-2076</p>	<p>Livonia GREAT RANCH CONDO IN SMALL COMPLEX Enjoy the open floor plan in this hard to find 3 BR, 2 BA Ranch condo Neutral decor t/o. Newer carpet & paint in most areas. Vaulted ceilings in MBR, GR & kit. (26100078) \$232,900 Barb Williamson 248-207-1565</p>	<p>Redford Calling Investors, this is it! Immaculate brick dplx 2-2 bed units both w/FP, loaded w/charm. 3.5 Det. garage, perfect storage. Bsmt w/laundry. New roof. (26081350) \$169,900 Debbie James 734-231-0097</p>



ONE WEB SITE: ALL THE HOMES

RealEstateOne.com

Over 30,000 Properties



Real Estate One, Inc. 2000



\$399,900 - Green Oak
Stunning 4 BR colonial, new construction!
248-437-3800



\$194,900 - South Lyon
Gorgeous 3 BR ranch!
248-437-3800



\$550,000 - South Lyon
Ranch with 8.91 acres!
248-437-3800



\$229,000 - Hamburg
Charming colonial with great yard!
248-437-3800



\$158,900 - Milford
Immaculate home with updates
248-437-3800



\$294,900 - Green Oak
Well maintained home with guest suite & pool!
248-437-3800



\$289,000 - Farmington
Custom built 3 BR Col
248-348-6430/349-6200



\$137,500 - Northville
2 BR end unit Condo
248-348-6430/349-6200



\$353,500 - Novi
Lovely Col on pretty lot
248-348-6430/349-6200



\$209,900 - Northville
2 BR Northville Condo
248-348-6430/349-6200



\$319,900 - Novi
Tastefully decorated 3 BR Col
248-348-6430/349-6200



\$399,000 - South Lyon
Ranch on 1 acre wooded lot
248-348-6430/349-6200



\$1,250,000 - Northville
4 BR, 4.5 BA w/ fin bsmt
248-348-6430/349-6200



\$332,000 - Northville
4 BR, 2.5 BA on 1.8 acres
248-348-6430/349-6200



\$469,900 - Brighton
4 BR 3.1 BA overlooks 6th green
248-348-6430/349-6200



\$209,900 - South Lyon
Remodeled 3 BR Col
248-348-6430/349-6200



\$375,000 - Novi
4 BR, 2.2 BA home
248-349-6200/348-6430



\$198,900 - Linden
3 BR 2.1 BA home
248-349-6200/348-6430



\$349,900
Massive GR w/ FP.
Oak winding staircase.
248-684-1065



\$1,575,000
Lg DR to pond & waterfall.
440' on Lake Sherwood.
248-684-1065



\$194,900
Walk to downtown!
2/3 br, 1 ba, 800 sq ft & shed.
248-684-1065



\$149,900
Five acres.
Well and septic.
248-684-1065



\$339,900
Main floor master.
Computer nook.
248-684-1065



\$484,900
Immaculate waterfront home.
All sports lake.
248-684-1065

\$234,900 - New Hudson
Nice ranch with finished basement
248-437-3800 2605120

\$779,900 - Milford
Spectacular ranch on 4.67 acres w/pond!
248-437-3800 2605287

\$187,900 - Whitmore Lake
Newer ranch with granite countertops!
248-437-3800 2605089

\$240,000 - Salem
Charming 1800's home completely updated!
248-437-3800 2607067

\$279,900 - Salem
4 BR ranch on 8 private acres!
248-437-3800 2607352

\$269,900 - Howell
Former model ready to be home
248-437-3800 2607074

\$399,900 - Green Oak
Stunning 4 BR colonial, new construction!
248-437-3800 26045620

\$272,900 - Green Oak
Spacious updated ranch with pond on 2.6 acres!
248-437-3800 2515729

\$274,500 - Green Oak
Cape Cod on 1.29 Acres!
248-437-3800 2610453

\$179,900 - Green Oak
Super 3 BR ranch with canal frontage
248-437-3800 2518230

\$334,900 - Green Oak
Gorgeous 4 BR colonial backs to wetlands!
248-437-3800 2609419

\$279,900 - Green Oak
4 BR colonial with open floor plan!
248-437-3800 26013008

\$579,900 - Brighton
Great Ranch w/lake frontage!
248-437-3800 26057970

\$398,500 - South Lyon
Beautiful cape cod with very private setting!
248-437-3800 2608553

\$169,000 - Brighton
7+ splittable acres
248-348-6430/349-6200 24080021

\$2000/month - Brighton
Ranch Condo for lease
248-348-6430/349-6200 25155584

\$675,000 - Northville
4 BR 2.5 BA Victorian
248-348-6430/349-6200 26103302

\$195,000 - Ferndale
Investment income potential
248-348-6430/349-6200 26105286

\$169,900 - Southfield
Cozy 3 BR Ranch
248-348-6430/349-6200 26096417

\$735,000 - Pleasant Ridge
Totally charming 4 BR Col
248-348-6430/349-6200 26105288

\$149,900 - Redford
Spacious, updated bungalow
248-348-6430/349-6200 26106865

\$159,900 - Novi
1 acre vacant land
248-348-6430/349-6200 26106846

\$154,800 - Dearborn
5 BR, 2.5 BA remodeled home
248-348-6430/349-6200 26077200

\$200,000 - Novi
1 acre lot w/ N'ville schools
248-348-6430/349-6200 25172244

\$119,500 - Keego Harbor
Investors! Perfect rental opportunity
248-348-6430/349-6200 26096458

\$175,000 - Novi
Ranch on 1/4 acre
248-348-6430/349-6200 26082999

\$199,500 - Farmington
3 BR Ranch Condo
248-348-6430/349-6200 26080529

\$179,500 - Commerce
Completely updated Ranch
248-349-6200/348-6430 26080517

\$286,000
Waterfront on Lake Oakland. Sea wall and dock.
248-684-1065 26081129

PENDING \$239,000
Hard W.O.L.L. Open kit & bkt bar.
248-684-1065 26067901

\$172,289
4 fenced lots w/pond! Finished basement.
248-684-1065 26047286

\$569,900
Spectacular 2004 4br, 3.1 ba home. On 3.5 acres.
248-684-1065 26083370

\$397,900
Kensington on 2.5 acres. Barn w/corral.
248-684-1065 26098629

\$274,900
Gorgeous home & neighborhood. All wall brick tp.
248-684-1065 26021724

\$159,900
Lg fenced backyard w/ nice deck. Part fin bsmt.
248-684-1065 26055905

\$184,900
Kit w/ new Formica counter. 3 season sun room.
248-684-1065 26074025

\$339,900
Brazilian cherry flrs. Big lot-lots of lg windows.
248-684-1065 26103651

\$449,900
4 br, 3.5 ba, 2 tp, 1st flr mstr ste.
248-684-1065 26054363

\$385,000
LR w/ trey cell & tp. Urfin bonus rm over garage.
248-684-1065 26057386

\$229,900
2 decks. Fin bsmt, 6 person cedar sauna.
248-684-1065 26051746

\$199,900
Spacious 4 br, 2.5 ba colonial. On 1.2 acre.
248-684-1065 26084565

\$289,900
Charming farmhouse on 5 acres. Wraparound porch.
248-684-1065 26100258

Milford (248) 684-1065 • Northville (248) 349-6200 • Novi (248) 348-6430 • South Lyon (248) 437-3800



JULY 4TH

Better Sleep Mattress World Sale!



Every Sleep Set

UP TO **50% OFF**
JULY 4TH BONUS CASH



Closeout!
NOW ONLY!

**SUPER
PREMIUM
PLUSH**

\$614

Queen 2pc. Sleep Set

Posturepedic
Support you trust. Comfort you'll love.™
**THIS POSTUREPEDIC DEAL
JUST CAN'T BE BEAT**
Was \$1249
*after closeout coupon applies

CLOSEOUT CASH
Yes! Take an Additional
\$54 OFF
Our CLOSEOUT Price
All Sealy Posturepedic
Sleep sets \$500 & up
COUPON

CLOSEOUT CASH
Yes! Take an Additional
\$74 OFF
Our CLOSEOUT Price
All Sealy Posturepedic
Sleep sets \$700 & up
COUPON



NOW ONLY!

Compare at
\$1399 On Sale
**JULY 4TH
BONUS BUY**

\$694

Queen 2pc. Sleep Set

CLOSEOUT CASH
Yes! Take an Additional
\$104 OFF
Our CLOSEOUT Price
All Sealy Posturepedic
Sleep sets \$1000 & up
COUPON

CLOSEOUT CASH
Yes! Take an Additional
\$154 OFF
Our CLOSEOUT Price
All Sealy Posturepedic
Sleep sets \$1400 & up
COUPON

No Sales Tax
ON ALL Beautyrest

FREE JULY 4TH BONUS #1
FREE "HARVARD" BEDFRAME
Receive a heavy duty "Harvard" Roller Bedframe with any sleep set purchase \$699 & up
Expires July 4th 2006
COUPON • COUPON • COUPON • COUPON

FREE JULY 4TH BONUS #2
Sleep FREE!
UP TO ONE YEAR!
Choose your new sleep set today, sleep great tonight and Pay No Interest or No Payments up to One Year. *D.A.C. See Store For Details
COUPON • COUPON • COUPON • COUPON

Plus Your Choice of any 2 July 4th Bonuses

FREE JULY 4TH BONUS #3
FREE Visco-Elastic Memory Foam Contour Pillows \$79
YES! FREE! With any sleep set purchase \$499 and up. Hurry! Supplies limited to first 100 Sleep Sets. Excludes Tempur-Pedic. See store for special online promotions. Expires July 4th 2006.
COUPON • COUPON • COUPON • COUPON

FREE JULY 4TH BONUS #4
FREE DELIVERY*
 SETUP*
Expert REMOVAL*
OF OLD BEDDING
COUPON • COUPON • COUPON • COUPON

Mattress World

"We Simply Do it Better!"

Mattress World
SUPERSTORE

Michigan's Premier Sleep Superstore

Mattress World
SUPERSTORE

JULY 4TH BETTER SLEEP SALE!

Discover Better Sleep Independence For Less!
Best Deals Of The Year On **"Best Buys"**

<p>Classic Premium Plush Beautyrest \$699 RollBack! Queen 2pc. Set Was \$1299 SALE ROLLBACK NOW Twin 2pc. Set \$559 Full 2pc. Set \$669 Queen 2pc. Set \$799 King 3pc. Set \$939</p>	<p>Super Premium Luxury Plush Pillowtop Beautyrest \$799 RollBack! Queen 2pc. Set Was \$1699 SALE ROLLBACK NOW Twin 2pc. Set \$659 Full 2pc. Set \$769 Queen 2pc. Set \$899 King 3pc. Set \$1099</p>	<p>Ultra Premium Luxury Firm Beautyrest \$899 RollBack! Queen 2pc. Set Was \$1499 SALE ROLLBACK NOW Twin 2pc. Set \$729 Full 2pc. Set \$839 Queen 2pc. Set \$969 King 3pc. Set \$1149</p>
--	--	---

<p>Ultra Premium Pillowtop Beautyrest \$899 RollBack! Queen 2pc. Set Was \$1199 SALE ROLLBACK NOW Twin 2pc. Set \$729 Full 2pc. Set \$839 Queen 2pc. Set \$969 King 3pc. Set \$1149</p>	<p>WorldClass Luxury Firm or Super Pillowtop Beautyrest \$1099 RollBack! Queen 2pc. Set Was \$1499 SALE ROLLBACK NOW Twin 2pc. Set \$929 Full 2pc. Set \$1039 Queen 2pc. Set \$1169 King 3pc. Set \$1449</p>	<p>WorldClass Exceptional Point-Ax-Roches Pillowtop Beautyrest \$1799 RollBack! Queen 2pc. Set Was \$2299 SALE ROLLBACK NOW Twin 2pc. Set \$1499 Full 2pc. Set \$1609 Queen 2pc. Set \$1739 King 3pc. Set \$2199</p>
---	--	--

CLOSEOUT CASH
Yes! Take an Additional **\$54 OFF**
Our CLOSEOUT Price
All Posturepedic
Sleep sets \$500 & up
COUPON

CLOSEOUT CASH
Yes! Take an Additional **\$74 OFF**
Our CLOSEOUT Price
All Posturepedic
Sleep sets \$700 & up
COUPON

CLOSEOUT CASH
Yes! Take an Additional **\$104 OFF**
Our CLOSEOUT Price
All Posturepedic
Sleep sets \$1000 & up
COUPON

CLOSEOUT CASH
Yes! Take an Additional **\$154 OFF**
Our CLOSEOUT Price
All Posturepedic
Sleep sets \$1400 & up
COUPON

GENTLE FIRM
Sealy **\$388**
Closeout! NOW
FULL 2PC SLEEP SET • REGULAR \$499

SIMPLY PLUSH
Sealy **\$488**
Closeout! NOW
FULL 2PC SLEEP SET • REGULAR \$599

ULTRA PREMIUM PLUSH COMFORT
Sealy **\$688**
Closeout! NOW
QUEEN SLEEP SET • REGULAR \$1249

ULTRA PREMIUM DREAM FIRM
Sealy **\$788**
Closeout! NOW
QUEEN SLEEP SET • REGULAR \$1399

PRESTIGE LUXURY PLUSH
Sealy **\$888**
Closeout! NOW
QUEEN 2PC LUXURY SLEEP SET • REGULAR \$1799

PRESTIGE LUXURY ULTRA PILLLOWTOP
Sealy **\$988**
Closeout! NOW
QUEEN 2PC LUXURY SLEEP SET • REGULAR \$1999

Plus Your Choice of any 2 July 4th Bonuses

JULY 4TH BONUS #1
FREE **"HARVARD" BEDFRAME**
Receive a heavy duty "Harvard" Roller Bedframe with any sleep set purchase \$699 & up Expires July 4th 2006
COUPON • COUPON • COUPON • COUPON

JULY 4TH BONUS #2
FREE **Sleep FREE! UP TO ONE YEAR!**
Choose your new sleep set today, sleep great tonight and Pay No Interest on No Payments up to One Year. *A.C. See Store For Details
COUPON • COUPON • COUPON • COUPON

JULY 4TH BONUS #3
FREE **Visco-Elastic Memory Foam Contour Pillows**
With any sleep set purchase \$99 and up
COUPON • COUPON • COUPON • COUPON

JULY 4TH BONUS #4
FREE **DELIVERY • SETUP • REMOVAL**
Minimum Purchase Required
COUPON • COUPON • COUPON • COUPON

Signature Collection MORGAN LATEX SUPER PLUSH PILLLOWTOP
Sealy **\$288**
Closeout! NOW
QUEEN 2PC LUXURY SLEEP SET • REGULAR \$2599

Signature Collection MORGAN LATEX SUPER PLUSH PILLLOWTOP
Sealy **\$288**
Closeout! NOW
TWIN SLEEP SET FULL SLEEP SET KING SLEEP SET
REG. AT \$1499 REG. AT \$1799 REG. AT \$2499
Plus Additional \$50 to \$150 Off Closeout

Signature Collection MORGAN LATEX SUPER PLUSH PILLLOWTOP
Sealy **\$288**
Closeout! NOW
TWIN SLEEP SET FULL SLEEP SET KING SLEEP SET
REG. AT \$1499 REG. AT \$1799 REG. AT \$2499
Plus Additional \$50 to \$150 Off Closeout

Sealy **Super Bonus July 4th Buy!**
NOW ONLY!
Posturepedic Signature Collection
THIS POSTUREPEDIC DEAL JUST CAN'T BE BEAT Was \$1999
*after Closeout Cash Coupon applied.
\$999
Queen 2pc. Sleep Set

"Bull Pen" Bonus Buys!

<p>Mattress World Signature Collection Muskegon \$109 TWIN MATTRESS</p>	<p>Mattress World Signature Collection Yukon \$139 TWIN MATTRESS</p>	<p>Mattress World Signature Collection Petoskey Gentle Firm \$259 TWIN MATTRESS</p>	<p>Mattress World Signature Collection Petoskey Gentle Firm \$299 TWIN MATTRESS</p>
---	--	---	---

<p>\$199 TWIN 2pc. \$269 FULL SET</p>	<p>\$159 FULL MATT. \$189 QUEEN MATT.</p>	<p>\$229 TWIN 2pc. \$299 FULL SET</p>	<p>\$189 FULL MATT. \$229 QUEEN MATT.</p>	<p>\$348 TWIN 2pc. \$389 FULL SET</p>	<p>\$298 FULL MATT. \$299 QUEEN MATT.</p>	<p>\$399 TWIN 2pc. \$489 FULL SET</p>	<p>\$389 FULL MATT. \$399 QUEEN MATT.</p>
---	---	---	---	---	---	---	---

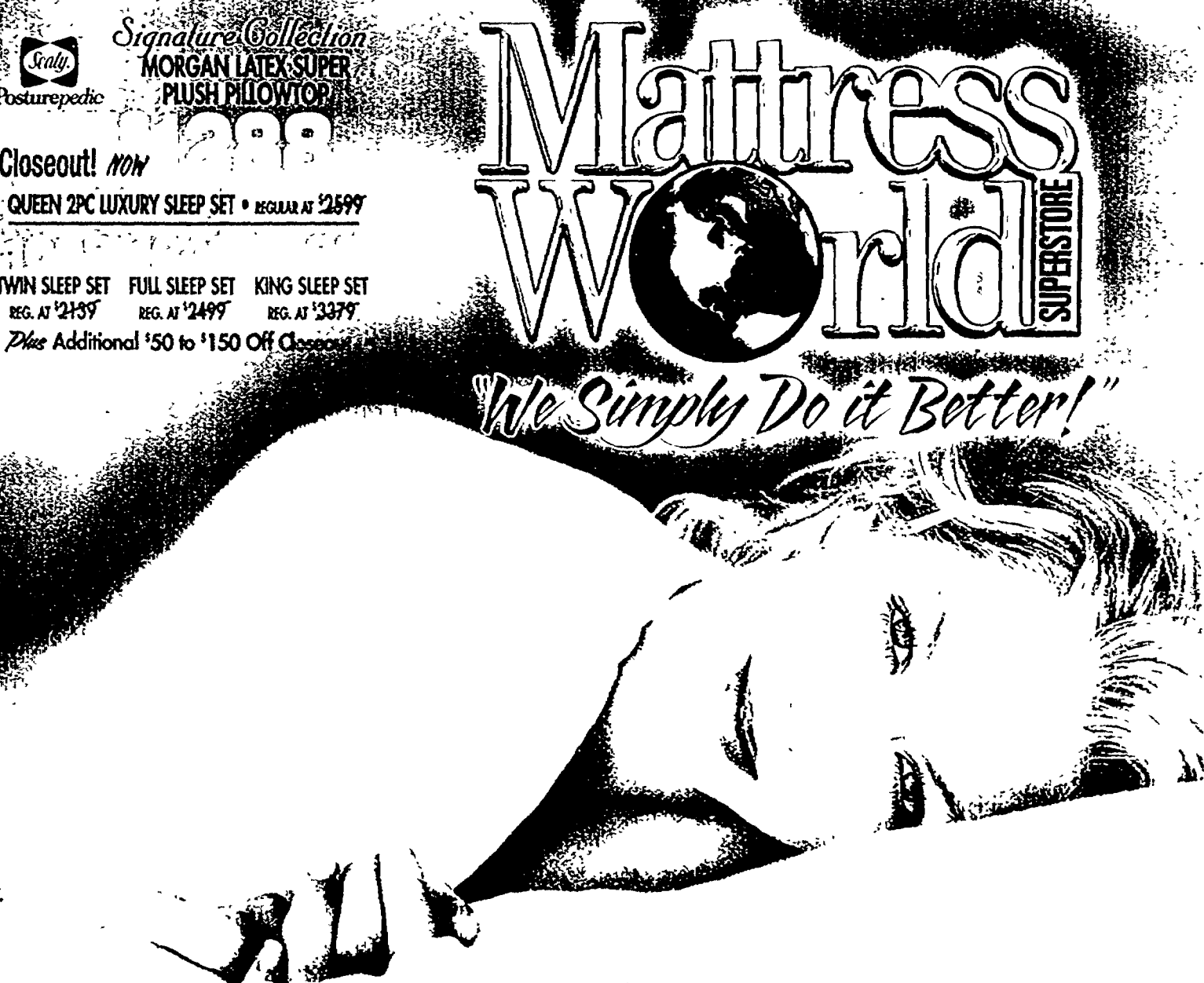

Mattress World
SUPERSTORE

We Simply Do it Better!

Look for the Yellow Tags and save on the items you buy most throughout the store!



WE HAVE LOWERED PRICES

Right Store. Right Price.

Pharmacies Open 4th of July



NOW OVER 10,000 YELLOW TAG SAVINGS WEEKLY

4th of July Sizzlin' Savings

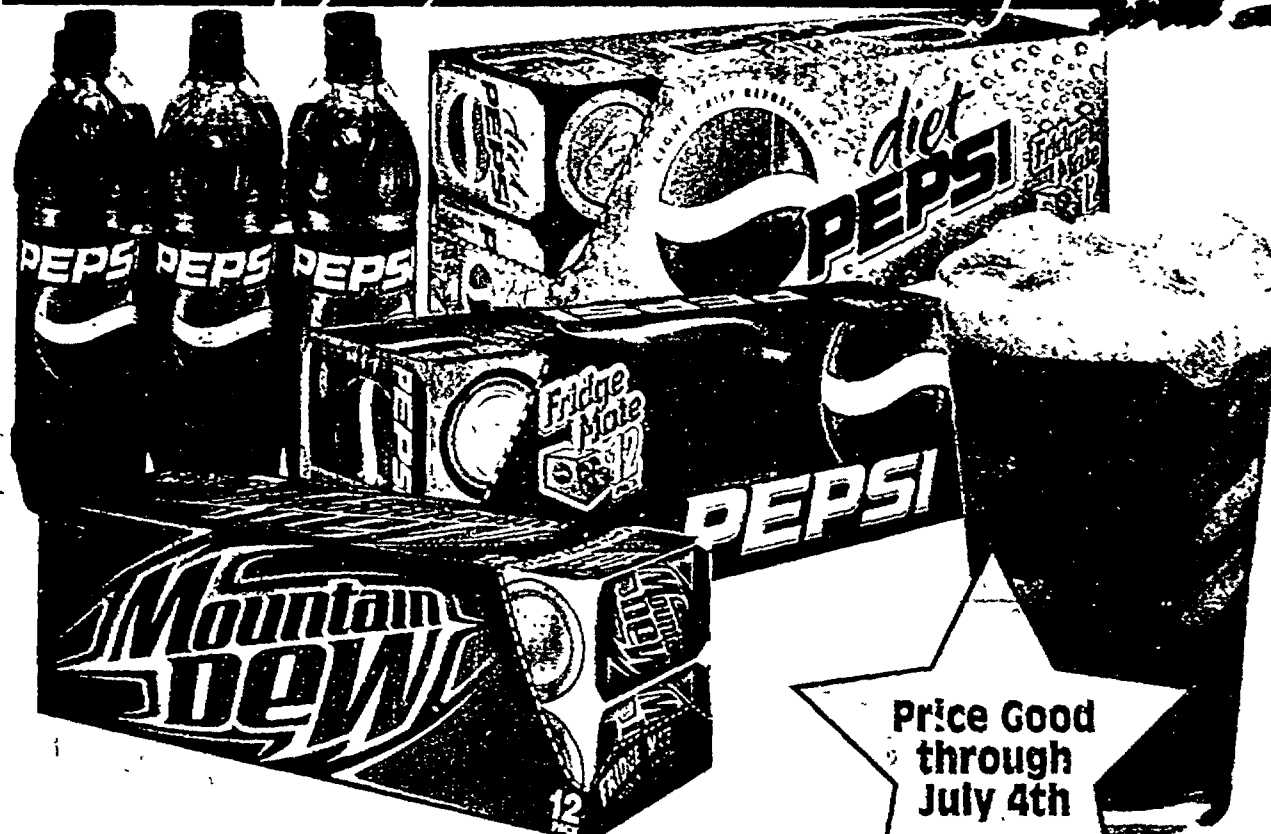

When You Buy

4 Pepsi 12 Packs or 6 Pack, 24 oz Btls.... **4\$10**
Get 1 Pepsi 12 Pack.... **Free!***

Final Cost

12 Pack Pepsi Products
12 oz Cans or 6 Pack 24 oz Btls
All Varieties

5\$10
for

WITH **Plus**

*Offer good with Plus Card, must purchase 5 products in one transaction. Limit 1 offer per transaction.

Price Good through July 4th



Price Good through July 4th

Whole Boneless Beef Rib Eye

USDA Select Beef Rib Value Pack
5 steaks or more 5.99 lb

4.97 lb

WITH **Plus**

Price Good through July 4th

Whole Seedless Watermelon

2.99

WITH **Plus**

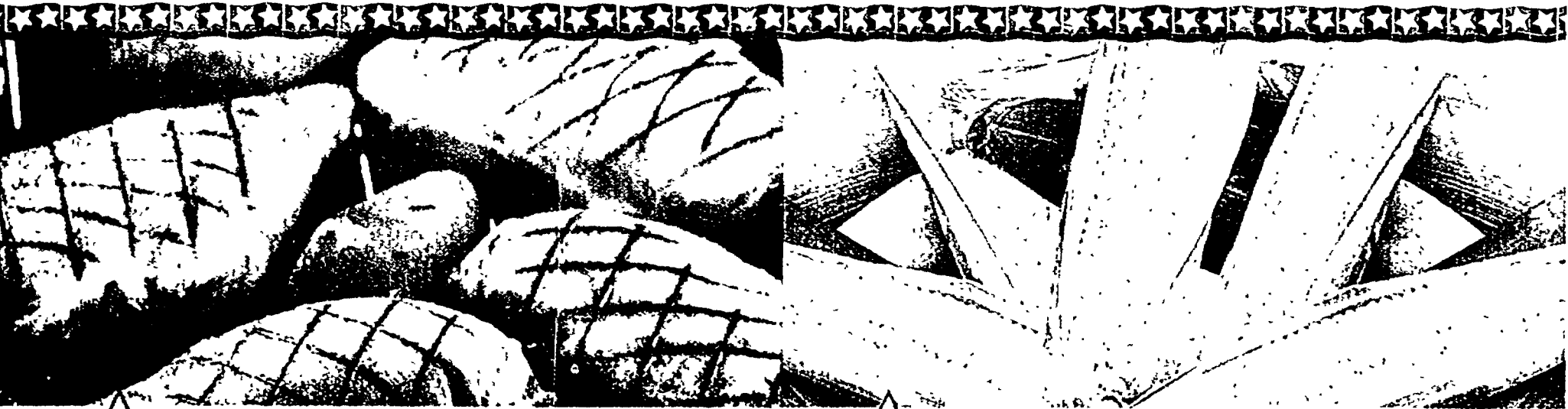

Price Good through July 4th

Amick Farms Fresh Boneless Skinless Chicken Breasts

USDA Inspected Value Packs or Smaller Package 1.99 lb

1.77 lb

WITH **Plus**

Price Good through July 4th

Sweet Corn In-Husk

14\$2 for

WITH **Plus**

Celebrate the Holiday!

Prices and Items good at your local Kroger Store through July 2, 2006.

10\$10

SALE



7-UP 6 Pack Cans
All Varieties
12 oz Cans

10\$10

for

Limit 10 total with \$10 purchase (Excluding alcohol, tobacco, fuel and prescriptions) **Plus**



Kroger Tender Twist Bread
20 oz or 8 ct Kroger Sandwich or Hot Dog Buns
All Varieties Except Jumbo

10\$10

for

WITH Plus



Cool Whip
8 oz Carton
All Varieties

10\$10

for

WITH Plus



Kroger Salad Dressing
16 oz Btl or Kroger Croutons
5 oz All Varieties

10\$10

for

WITH Plus



Gatorade Sports Drink
32 oz Btl
All Varieties

10\$10

for

WITH Plus



Kroger Bagged Snacks
3-16 oz Bag
All Varieties Except Super Size

10\$10

for

WITH Plus



Kroger Cottage Cheese, Sour Cream or Dips
16 oz All Varieties
(Excludes Special Recipe Dips)

10\$10

for

WITH Plus



Pillsbury Truckload Sale!
Select Varieties Grand! Biscuits 10.2 oz, Golden Biscuits 10 ct, Cinnamon Rolls 7 oz, Crusty French Loaf 11 oz, Pizza Crust 13.8 oz or Breadsticks 11 oz. While Supplies Last!

10\$10

for

WITH Plus



Kool-Aid Bursts Drinks
6 Pack All Varieties

10\$10

for

WITH Plus



Lipton Noodles or Rice Side Dishes
4-9 oz All Varieties

10\$10

for

WITH Plus



Kroger Ice Cream Novelties
12 ct Twin Pop, 6 ct Eclairs or 8 ct Ice Cream Sandwiches

10\$10

for

WITH Plus



6 Pack Big K Soft Drinks
12 oz Cans All Varieties

10\$10

for

WITH Plus

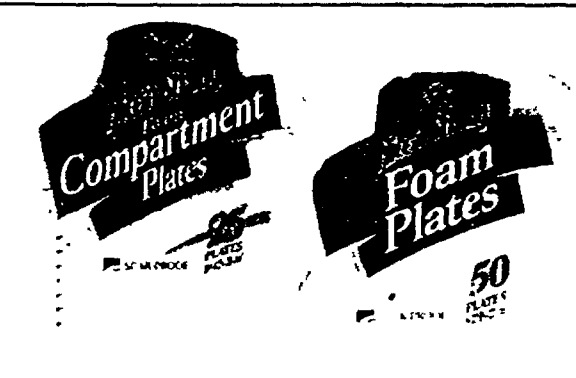

Kroger Foam Plates
50ct or 25 ct Compartment

10\$10

for

WITH Plus



Kroger Ketchup
24 oz or 12 oz Brown or 14 oz French's Yellow Mustard

10\$10

for

WITH Plus



Healthy Choice Familiar Favorites
or Marie Callender's Chicken Pot Pie 9-10 oz

10\$10

for

WITH Plus



General Mills Chex Mix
8.75 oz or 8.6 oz Gardetto's or 7.5 oz Bugles

10\$10

for

WITH Plus



Nabisco Go-Paks!
2.75-4 oz or 2.125 oz Barnum's Animal Crackers

10\$10

for

WITH Plus



Frito Lay Stax
5.75-6 oz All Varieties

10\$10

for

WITH Plus



Kroger English Muffins
All Varieties
6 ct

10\$10

for

WITH Plus



Kroger Steak Sauce
10-16 oz Btl All Varieties or Marinades or Tabasco Pepper Sauce 2 oz

10\$10

for

WITH Plus

Summer Cookout



Sold in 10 lb Case for 69.90

Jumbo King Crab Legs and Claws

Frozen. Smaller Packages 7.99 lb

6.99 lb

WITH *Plus*



Flavor Seal Ground Chuck

USDA Inspected 5 lb Flavor Seal Pkg for 7.45 or Honeysuckle Ground Turkey Sold in 3 lb Pkg for 4.17 ea

1.49 lb

WITH *Plus*



Kroger Bratwurst

All Varieties 18 oz Pkg

2\$5 for

WITH *Plus*



Free Coca-Cola 2-Liter with the purchase of 3 Piece Chicken

Hottest Price of the Year!
8 Piece Fresh Baked or Fried Chicken

2-Breasts, 2-Thighs, 2-Legs and 2-Wings

3.99

WITH *Plus*



Deli or Bakery Party Trays

29.99 or Higher

5.00 Off

WITH *Plus*



Private Selection Apple or Apple Streusel Pie

9 Inch

4.99

WITH *Plus*



We accept ALL competitor's Pharmacy coupons!

We offer FREE prescription delivery!

We accept ALL third party prescription transfers!

See Pharmacist for full details.



All Kroger Pharmacies are Open July 4th!

Kroger cares about your privacy! Please view our current privacy policy at kroger.com or visit the customer service desk.

Prices and Items Good at All Central Ohio Area Kroger Stores June 29 thru July 2, 2006. Some Items may require a deposit. Visit our Website at www.Kroger.com or call Customer Service at 1-800-KROGERS

ADVERTISED ITEM POLICY: WE RESERVE THE RIGHT TO LIMIT QUANTITIES. Each of these advertised items is required to be available for sale. If we do run out of an advertised item, we will offer you your choice of a comparable item, when available, reflecting the same savings, or a raincheck which will entitle you to purchase the advertised item at the advertised price within 30 days. Only one vendor coupon will be accepted per item. Copyright 2006. The Kroger Company. No sales to dealers.

KOHL'S

Fri. June 30 8am-11pm
& Sat., July 1 7am-11pm

Original Kohlsville, PA store open Friday 9am-10pm & Saturday 7am-11pm

expect great things

2-DAY PRE-FOURTH OF JULY

SALE

featuring

POWER HOURS

DURING THESE SPECIAL HOURS,
GET OUR BEST PRICES ON
SELECT ITEMS IN THE STORE

 **SHOP NIGHT OWLS**

FRI. JUNE 30 3PM-11PM

Original Kohlsville, PA store open until 10pm

 **SHOP EARLY BIRDS**

SAT. JULY 1 7AM-1PM

 NIGHTOWL

 EARLYBIRD

Entire Stock

50-60% off

Swimwear for misses,
men, kids, juniors,
young men & women

orig. \$14-\$86, sale \$7-\$43
Excludes Columbia Sportswear Company®
selected items
online: SWIM



 NIGHTOWL

 EARLYBIRD

129⁹⁹

8" portable
DVD player

Includes carrying case,
headphones, A/C
adaptor, battery and
full-function remote.
orig. 269.99
While quantities last -
sorry no rain checks.



 NIGHTOWL

 EARLYBIRD

 NIGHTOWL

 EARLYBIRD

 NIGHTOWL

 EARLYBIRD

 NIGHTOWL

 EARLYBIRD



Entire Stock

50-60% off

Sonoma & apt. 9" knit tops
for misses, petites & women. orig. \$12-\$38,
sale \$6-\$19 SONOMA life+style™
selected items online P62901

selected items
online P62902



Entire Stock

60% off

Short-sleeved knit and
woven tops & shorts for men
from Sonoma, Croft & Barrow™ and Arrow.
orig. \$14-\$46, sale 5.60-18.40



Entire Stock

40-50% off

Athletic sandals
for the family. orig. 18.99-40.00,
sale 9.99-24.00



50-60% off plus
save an extra 10%

on entire stock of luggage
reg. 49.99-379.99, sale 24.99-189.99,
final price 22.49-170.99

NIGHTOWL EARLYBIRD



50-60% off

Nine & Company, axcess, daisy fuentes and AB Studio collections for misses, petites and women. orig. \$29-\$59, sale 14.50-29.50 Selected styles. selected items online P62912

NIGHTOWL EARLYBIRD



Entire Stock 50-60% off

Erika, Briggs and Notations separates for misses. orig. \$16-\$40, sale \$8-\$20

NIGHTOWL EARLYBIRD



Entire Stock 50-60% off

Cathy Daniels, Sag Harbor, Requirements, Norton McNaughton, Villager & West End collections for misses, petites & women. orig. \$22-\$74, sale \$11-\$37

NIGHTOWL EARLYBIRD

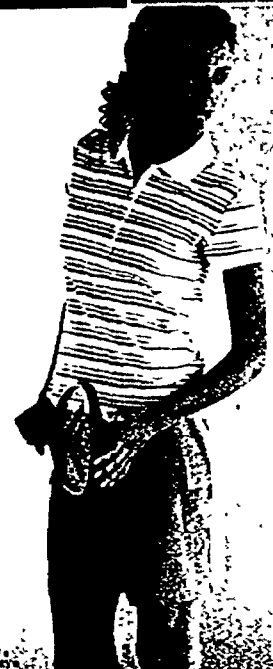

Entire Stock 50-60% off

Active & fitness wear for misses from N.Y.L., Gloria Vanderbilt Sport, daisy fuentes sport, Fu Da & Tek Gear. orig. \$14-\$40, sale 5.60-20.00 selected items online P62913

POWER HOURS

DURING THESE SPECIAL HOURS, GET OUR BEST PRICES ON SELECT ITEMS IN THE STORE

Selected Night Owls & Early Birds also available online.

NIGHTOWL EARLYBIRD

Entire Stock 50-60% off

Handbags & minibags orig. \$15-\$65, sale 7.50-32.50

selected items online W1600

13.99 apt. 9" Tower handbags. orig. \$36



NIGHTOWL EARLYBIRD

Entire Stock 5.99

SO... patriotic & Corona flip-flops for her. orig. \$14 Accessories dept.

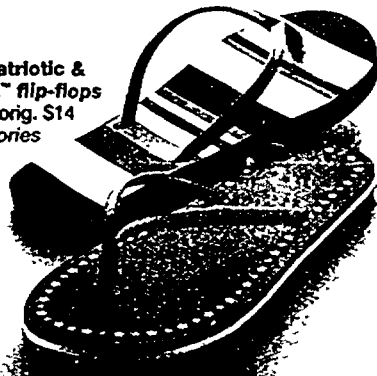

NIGHTOWL EARLYBIRD

4.99

SO... tees and tank tops for juniors. orig. \$12 Selected styles. selected items online P62914

SO



NIGHTOWL EARLYBIRD



7.99

Graphic tank tops & tees, shorts and skirts for juniors. orig. \$18 Excludes MJ Softe

NIGHTOWL EARLYBIRD

25-50% off plus

on entire stock of watches reg. 19.95-550.00, sale 14.96-412.50, final price 12.71-350.62

selected items online F999

RELIC

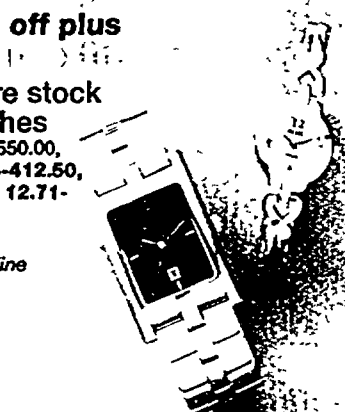

NIGHTOWL EARLYBIRD

Entire Stock 33-50% off

Fashion jewelry orig. \$6-\$28, sale 3.60-18.76 Excludes Napier and 1928. selected items online P62915

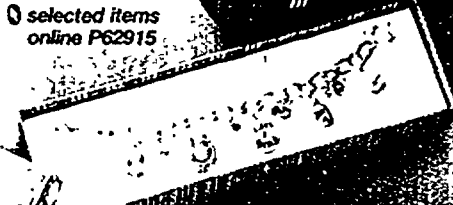

NIGHTOWL EARLYBIRD

Entire Stock 11.99

Fashion shorts for juniors from Angels, Bongo, i.e.i., Unionbay and Mudd. orig. \$26

Angels

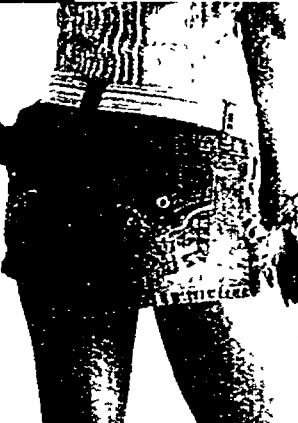

NIGHTOWL EARLYBIRD



Entire Stock 60% off

Shorts for boys 8-20. orig. \$22-\$40, sale 8.80-16.00 Excludes athletic & collections.

NIGHTOWL EARLYBIRD



Entire Stock 55% off

Sundresses for girls 4-16, toddlers, infants and newborns.

NIGHTOWL EARLYBIRD

Entire Stock 50-60% off

Summer playwear for boys 4-7, toddlers and girls 4-6x. Playwear not intended as sleepwear.



NIGHTOWL EARLYBIRD

Entire Stock 60% off

Summer sets for girls 4-6x, boys 4-7 and toddlers.



NIGHTOWL EARLYBIRD

10-40% off plus Save an extra 15% on entire stock of toys



152.99 Final Price Banzai Blast inflatable water slide. 18' long, 8' high; includes blower, carrying bag & repair kit. Maximum weight capacity 100 lbs. orig. 249.99, sale 179.99

NIGHTOWL EARLYBIRD



50-60% off

Casual pants for men from Axist, Croft & Barrow and Sonoma. orig. \$40-\$45, sale 16.00-22.50. Selected styles. SONOMA life+style. shop online P62918

NIGHTOWL EARLYBIRD

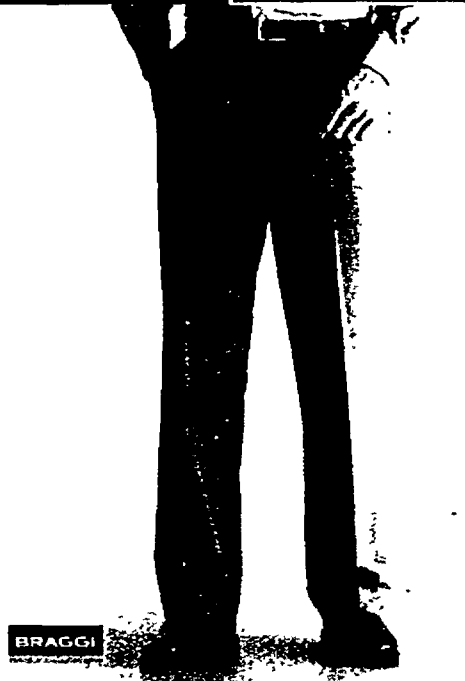

Entire Stock 50-60% off

Dress pants for men from Braggi, Axist, Chaps and Croft & Barrow. orig. \$45-\$75, sale \$16-\$30. shop online P62919

NIGHTOWL EARLYBIRD



Entire Stock 99.99

Men's herringbone suit separates for men. Mid-weight three-button suit separates ideal for dress and casual looks. orig. \$65-\$200, sale 24.99-75.00

NIGHTOWL EARLYBIRD

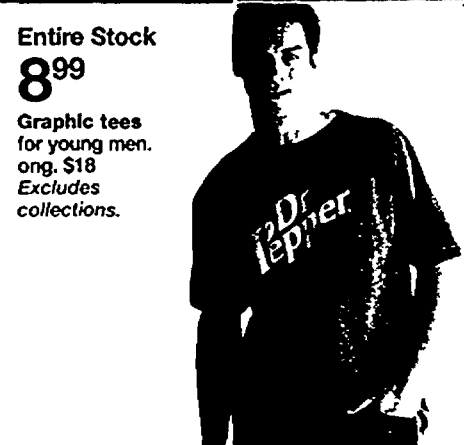

Entire Stock 8.99 Graphic tees for young men. org. \$18 Excludes collections.

NIGHTOWL EARLYBIRD

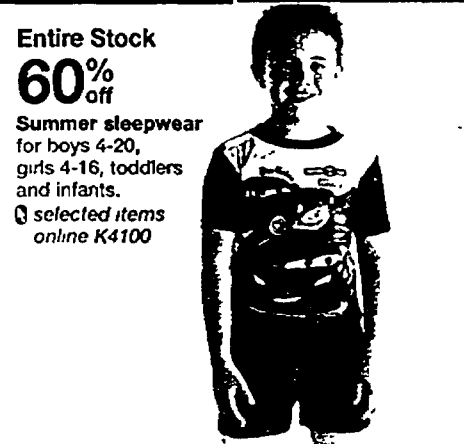

Entire Stock 60% off Summer sleepwear for boys 4-20, girls 4-16, toddlers and infants. selected items online K4100

SHOP NIGHT OWLS

FRIDAY, JUNE 30 3PM-11PM

Oxford Valley, PA store open until 10pm.

SHOP EARLY BIRDS

SATURDAY, JULY 1 7AM-1PM

NIGHTOWL EARLYBIRD



36.99

Athletic shoes for men and women from New Balance and Nike. reg. 59.99 Selected styles.

NIGHTOWL EARLYBIRD

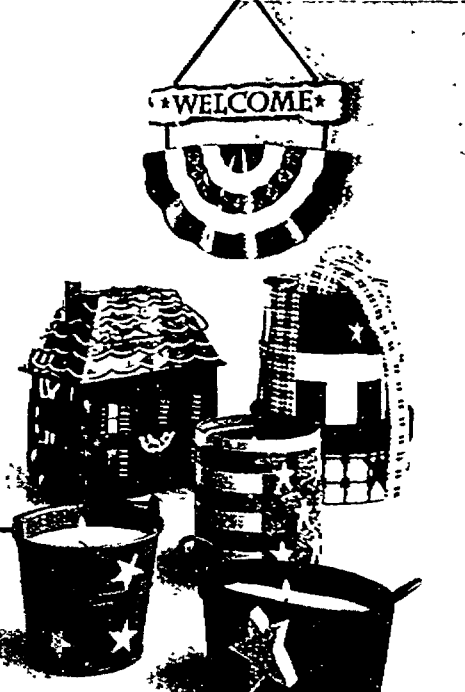

Entire Stock 60% off

Patriotic decor Includes candles, ceramics & more.

NIGHTOWL EARLYBIRD



99.99 Your choice Hoover WindTunnel Lite vacuum with onboard tools or Bissell PowerSteamer Pro deep cleaner. reg. 199.99 ea.

Entire Stock 20-50% off

Floor care shop online H1400

NIGHTOWL EARLYBIRD



50% off Pyrex and Corningware shop online P62916

NIGHTOWL EARLYBIRD

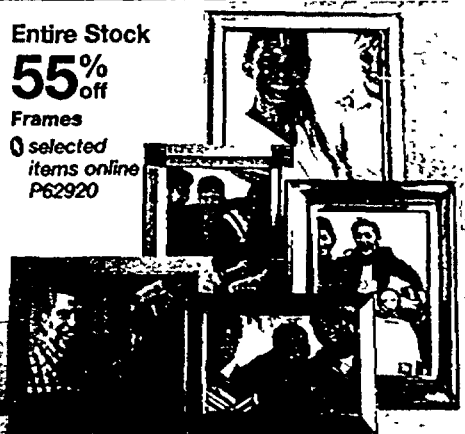

Entire Stock 55% off Frames selected items online P62920

NIGHTOWL EARLYBIRD



Entire Stock 55-60% off

Accent, area & kitchen rugs and doormats selected items online P62921

NIGHTOWL EARLYBIRD



Entire Stock 50% off Aerobed Classic reg. 129.99-199.99, sale 64.99-99.99

NIGHTOWL EARLYBIRD



161.99 Final Price Park Avenue queen comforter set. orig. 279.99, sale 179.99

NIGHTOWL EARLYBIRD



Entire Stock 55% off Flatware selected items online H2120

NIGHTOWL EARLYBIRD

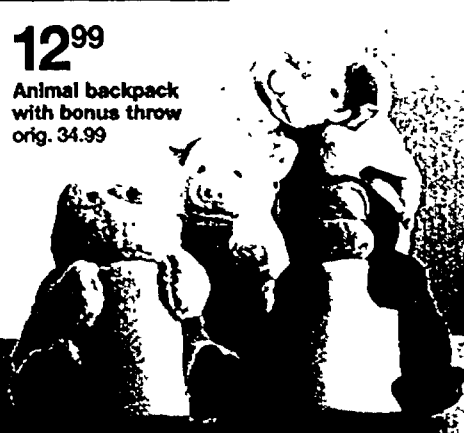

12.99 Animal backpack with bonus throw org. 34.99

30-50% off plus save an extra 10% on entire stock of comforters, accessories & bed in one bag sets shop online P62922

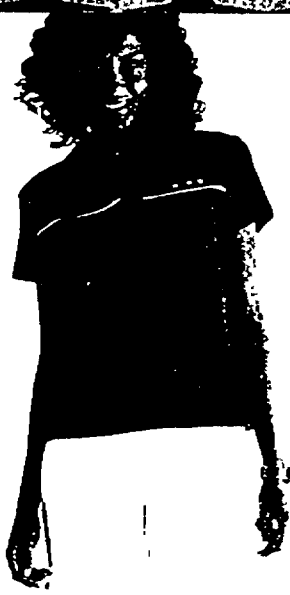

SONOMA

Save
40-50%

Sonoma sportswear for misses, petites and women. orig. \$12-\$39, sale 7.20-22.80. Selected styles. selected items online P62923

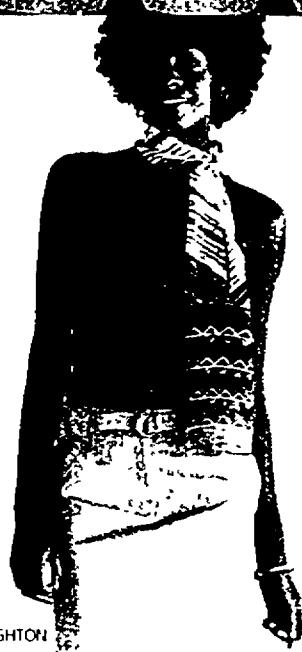

NORTON/MCNAUGHTON

Entire Stock
40-50% off

Norton McNaughton*, Requirements*, Villager*, Sag Harbor*, Cathy Daniels and West End collections for misses, petites and women. orig. \$22-\$74, sale 13.20-44.40

women's



ERIKA

Save
40-50%

Women's sportswear from Erika*, daisy fuentes*, apt. 9*, Sonoma & more. Sizes 1X-3X and 16W-24W. orig. \$14-\$66, sale 7.49-39.60. Selected styles.

selected items online P62924



TEK GEAR

Save
20-50%

Active and fitness wear for misses from Tek Gear*, Nike*, adidas*, Russell* Athletic*, Danskin*, N.Y.L.* and more. orig. \$12-\$54, sale 6.00-43.20. Selected styles.

entirestock

30-40% off

Fashion Jewelry orig. \$6-\$28, sale 4.02-19.60. Excludes Napier* and 1928*. selected items online P62915

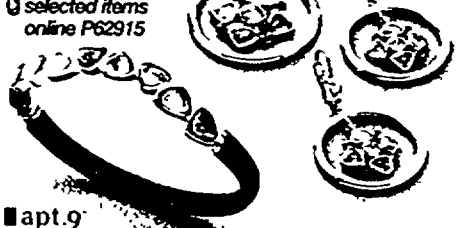

apt.9

Save
40-50%

Petites' sportswear from apt. 9*, Sonoma, Croft & Barrow*, daisy fuentes* and more. orig. \$12-\$60, sale 6.99-30.00. Selected styles.



petites

apt.9

2-DAY PRE-FOURTH OF JULY

entirestock

60% off

Sterling silver jewelry reg. \$10-\$150, sale \$4-\$60. selected items online F2200



7.99 ea. Sterling silver rings, reg. \$20 ea.

entirestock

40% off

Panties & innerwear reg. 3/\$15 to \$46 ea., sale 3/9.00 to 27.60 ea. Excludes Jockey* and bra coordinates.

40% off bras from Maidenform*, Barelythere*, Bali* & Olga* reg. \$20-\$32, sale 12.00-19.20. Selected styles.



Entire Stock

40% off

Sleepwear, loungewear & robes from SO... Rewind*, Mudd*, GLO* & I.e.i.* orig. \$12-\$40, sale 7.20-24.00. selected items online W2400



iz

Entire Stock

35-50% off

Collections for juniors. orig. \$28-\$58, sale 18.20-37.70. selected items online P62925

entirestock

60% off

Fine Jewelry selected items online F999



17.99 ea. Super Buy Entire stock boxed toe rings, anklets or earrings. 10k gold, orig. \$50 ea.

entirestock

35% off

Handbags, minibags & handbag and fashion accessories for her. orig. \$8-\$65, sale 5.20-42.25. selected items online W1600



entirestock

2/\$15

Carter's* rompers, sunsuits & dress sets for infants & newborns. orig. \$13-\$16 ea., sale 7.99 ea.



entirestock

40% off

Fashion tops for girls 4-16.



entirestock

35-50% off

Fashion capris and gauchos for juniors from SO... Rewind*, Mudd*, GLO* & I.e.i.* orig. \$28-\$34, sale 13.99-21.99



SO

entirestock

Save

40-50%

Woven tops and sweaters for juniors. orig. \$20-\$40, sale \$10-\$20. Selected styles. selected items online P62926

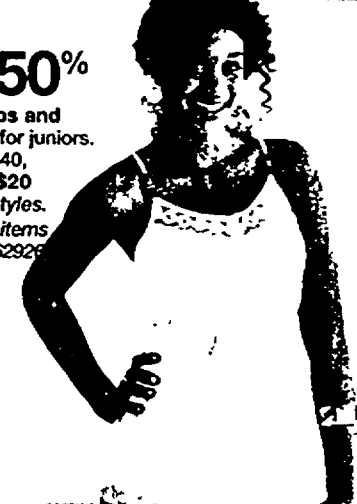

Jewelry photos enlarged to show detail. Diamond Total Weights are approximate. TW may vary up to .05 ct. Actual savings may exceed the percent savings shown.

gold star clearance



Entire Stock
50% off
Camp shirts for men from Hawaiian, California, Florida, National, and more. Excludes...
Shop online P62927

Entire Stock
50% off
Short-sleeved polo shirts for men from Arrow, Grand Slam, and more. Excludes...
Shop online P62928

Entire Stock
50% off
Golf tops for men from Grand Slam, Dockers, and Wedge. orig. \$24-\$50, sale 11.99-24.99
selected items online P62929

Entire Stock
16.99
Urban Pipeline™ twill & denim shorts for young men. orig. \$32-\$34

SALE

Save **25%**
Nike® athletic apparel for boys 8-20. orig. \$16-\$28, sale \$12-\$21. Selected styles.

entirestock
50% off
Short-sleeved polos for young men from Machine® and Urban Pipeline™. orig. \$28-\$34, sale \$14-\$17

entirestock
60% off
Summer Living® Patio Shop. selected items online H4500
23.99 Lawn games. orig. 59.99

entirestock
30-50% off Candles & decorative lighting. Excludes Yankee Candle®. shop online P62930

entirestock
40-50% off
Short-sleeved graphic tees for boys 4-7, girls 4-6x and toddlers. Excludes collections & athletic.

entirestock
30-50% off
Cross-training & walking shoes for men and women. reg. 49.99-64.99, sale 29.99-45.49. selected items online: SHOES
44.99 New Balance® 504 cross-training shoes for men. reg. 64.99
plus, all other athletic shoes on sale

entirestock
50-60% off
Solid bath towels, sheet sets & bath rugs. reg. 3.99-179.99, sale 1.99-89.99. selected items online P62931

entirestock
40-50% off Summer Stripe
Tabletop

entirestock
40-50% off Mudd
Sandals & shoes for juniors from Mudd® & Le.I.®. orig. 34.99-44.99, sale 20.99-26.99. shop online: SHOES
21.99 Mudd® Ballad. orig. 44.99
21.99 Le.I.® Falcon. orig. 44.99

entirestock
29.99
Casual shoes for men. orig. 59.99-69.99. Selected styles.
Croft & Barrow® Semler
Croft & Barrow® Brent

entirestock
50-60% off
Decorative pillows & slipcovers. orig. 14.99-179.99, sale 7.49-89.99. selected items online P62932

entirestock
selected items online P62933

save **70%** and more on original prices when you take an additional 50% off our already-reduced yellow ticket clearance prices

Final prices given at register. Clearance prices represent savings off original prices. Selection varies by store. Interim markdowns may have been taken. Sorry, no price adjustments given on prior purchases. selected items online: clearance

NIGHTOWL EARLYBIRD

Entire Stock
50-60% off

Croft & Barrow® tank tops, tees & polos for misses, petites & women. orig. \$14-\$18, sale \$7-\$9
selected items online P62903



POWER HOURS

Selected Night Owls & Early Birds also available online.

NIGHTOWL EARLYBIRD

60% off plus
an extra 15%
on entire stock of fine jewelry
& sterling silver jewelry
Extra 15% off excludes Super Buys.
shop online F999 & F2200

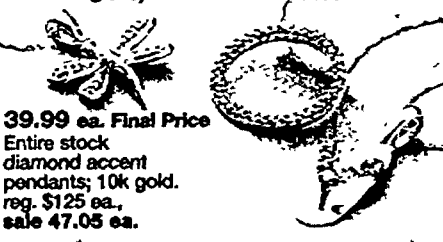

39.99 ea. Final Price
Entire stock diamond accent pendants; 10k gold. reg. \$125 ea., sale 47.05 ea.

NIGHTOWL EARLYBIRD

14.99

Bras from Warner's Playtex®, Lily of France & Vanity Fair®. reg. \$24-\$30
Selected styles.

50% off all pairs from Vanity Fair Maidenform®, Barelythere® & Warner's® reg. 3/16.50 to 9.99
sale 3/8.25 to 4.99
Excludes bra co.

selected items online P62903



SHOP NIGHT OWLS
FRI., JUNE 30 3PM-11PM

Oxford Valley, PA store open until 10pm.

SHOP EARLY BIRDS

SAT., JULY 1 7AM-1PM

NIGHTOWL EARLYBIRD

Entire Stock
9.99

Sunglasses for her or him. orig. \$20-\$25
Excludes polarized sunglasses.
selected items online P62905



NIGHTOWL EARLYBIRD

55-60% off

Shorts, capris and skorts for misses, petites & women from Lee®, Levi's®, Gloria Vanderbilt® & Dockers®. orig. \$30-\$40, sale \$12-\$18
Selected styles.
selected items online P62906



NIGHTOWL EARLYBIRD

Entire Stock
55-60% off

Shorts for young men from Unionbay®, Lee® Dungarees, U.S. Polo Assn. & Urban Pipeline®. orig. \$32-\$42, sale 14.40-18.90
selected items online P62907



NIGHTOWL EARLYBIRD

Entire Stock
60% off

Dress & casual sandals for the family. orig. 24.99-59.99, sale 9.99-23.99
Excludes Candie's® & Chaps for her.
selected items online: SHOES

2/\$18
Sandals for women. orig. 29.99 pr., sale 9.99 pr.

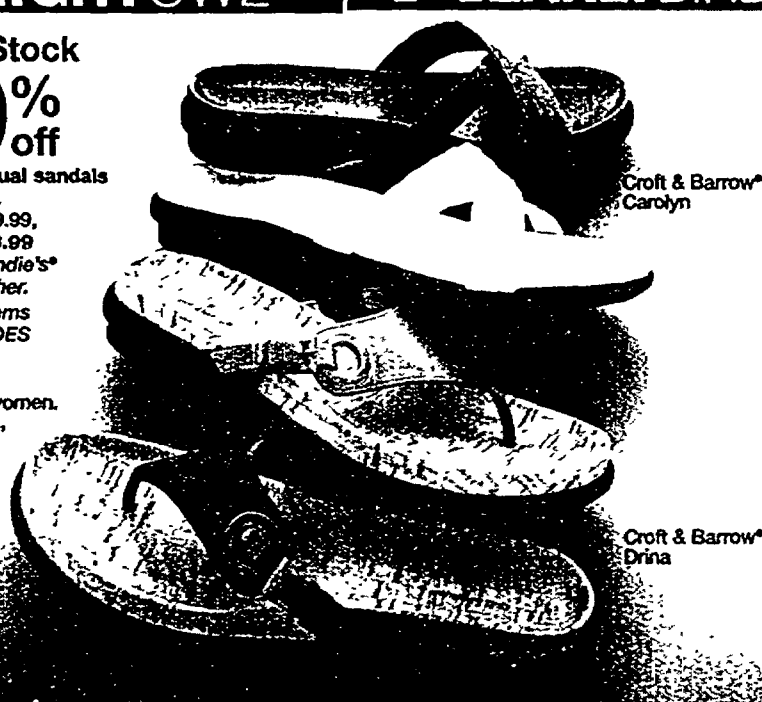

Croft & Barrow® Carolyn

Croft & Barrow® Drina

NIGHTOWL EARLYBIRD

10-50% off plus
an extra 10%

on entire stock of kitchen electrics

Includes food sealers, mixers, blenders, grills, slowcookers, coffeemakers & counter tops
selected items online H1600

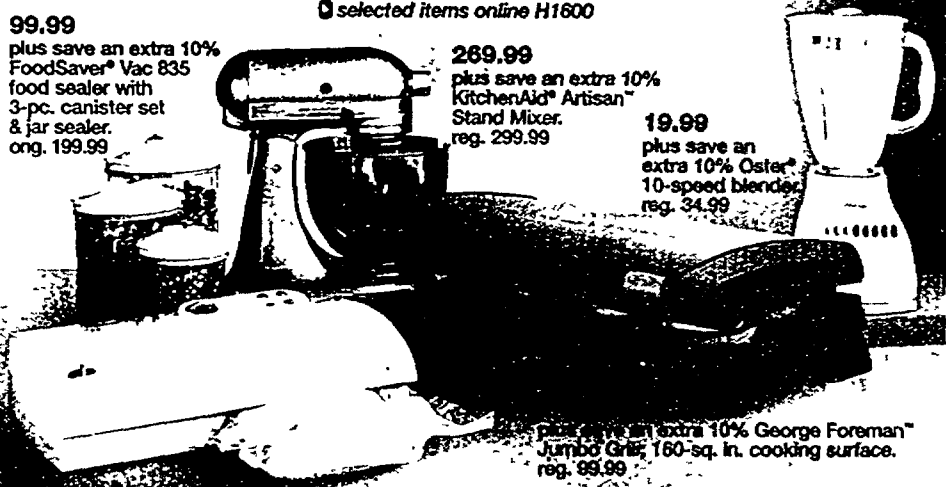

99.99 plus save an extra 10% FoodSaver® Vac 835 food sealer with 3-pc. canister set & jar sealer. orig. 199.99

269.99 plus save an extra 10% KitchenAid® Artisan™ Stand Mixer. reg. 299.99

19.99 plus save an extra 10% Oster® 10-speed blender. reg. 34.99

plus save an extra 10% George Foreman™ Jumbo Grill; 160-sq. in. cooking surface. reg. 99.99

NIGHTOWL EARLYBIRD

Entire Stock
50-60% off

Dress shirts and neckwear for men from Arrow and Croft & Barrow®. orig. \$25-\$44, sale 10.99-22.00
shop online P62909

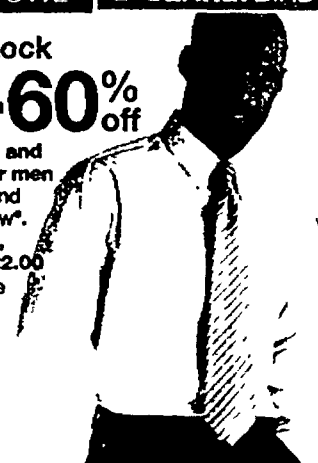

NIGHTOWL EARLYBIRD

Entire Stock
60% off

Golf tops for men from Wedge™ & Grand Slam™. orig. \$24-\$50, sale 9.60-19.99

selected items online P62910



NIGHTOWL EARLYBIRD

Entire Stock
50-60% off

Tank tops & shorts for girls 4-16, boys 4-7, toddlers, infants & newborns from SO... & Sonoma. SO... so real. so right.™ SONOMA life+style™.
selected items online P62911



NIGHTOWL EARLYBIRD

Entire Stock
60-70% off

Beach towels orig. 17.99-39.99, sale 7.19-18.99
selected items

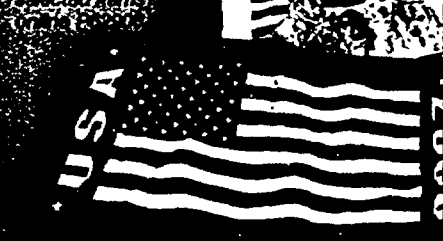

KOHL'S
expect great things

Prices good Fri., June 30-Sat., July 1, 2006.

Selection may vary by store. Some merchandise may not be available at every store. *Sale prices and percentage savings offered in this advertisement are discounts from Kohl's "Regular" or "Original" prices. The "Regular" or "Original" price of an item is the former or future offered price for the item or a comparable item by Kohl's or another retailer. Actual sales may not have been made at the "Regular" or "Original" prices, and intermediate markdowns may have been taken. Clearance merchandise is excluded from "Entire Stock" promotions in this advertisement. In some events, actual savings may exceed the percent savings shown. KOHL'S® and KOHL'S brand names are trademarks of Kohl's Illinois, Inc. ©2006 Kohl's Department Stores, Inc.

limited time offer



Open a Kohl's Charge and take 15% off your first day's Kohl's Charge purchases. Plus, Kohl's Charge customers enjoy additional discounts 12 times a year. Limited time offer good now-July 1, 2006. Subject to credit approval. See store for details.

For the Kohl's Store nearest you call 1-800-837-1500 or visit us on the Web at Kohls.com



5 DAYS ONLY!
SAVE ON ALL BEHR
INTERIOR AND
EXTERIOR PAINTS,
STAINS AND PRIMERS.
 See page 8 for more details **

\$6 OFF
 1-GALLON CANS BY MFR. MAIL-IN REBATE

\$25 OFF
 5-GALLON CANS BY MFR. MAIL-IN REBATE

10% OFF
FOR ALL ACTIVE
DUTY & MILITARY
VETERANS
 AND THEIR FAMILIES 6/29 THROUGH 7/04/06.
 MAXIMUM DISCOUNT \$200. PICK UP A
 COUPON AT THE SERVICES DESK.
 SEE BACK COVER FOR DETAILS.

CELEBRATION DAYS JULY 4TH SAVINGS EVENT

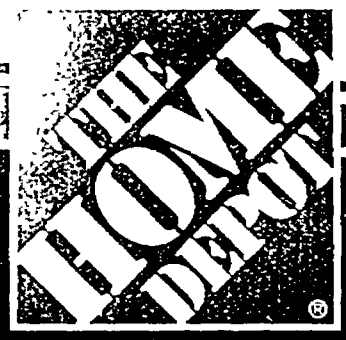

You can do it. We can help.™

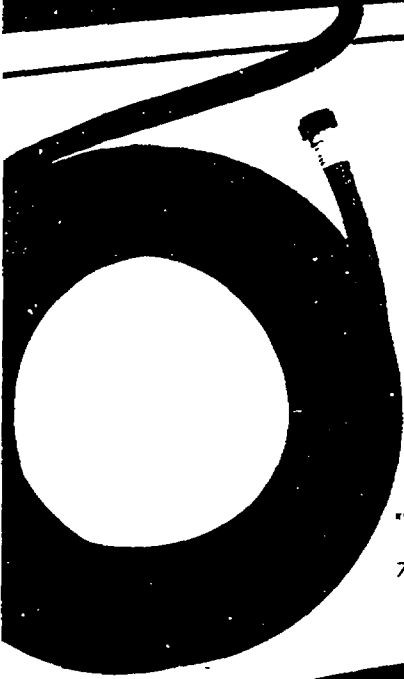

SPECIAL BUY!
\$5.88
 50' SOAKER HOSE
 "Weeping" watering
 act on uses up to
 70% less water than
 watering with a
 sprinkler. (341047)



MILLSTEAD
\$5.97 EACH
 4"x4"-8' PRESSURE
 TREATED POST
 Approved for ground contact
 Treated to resist insects,
 rot and decay. (256276)

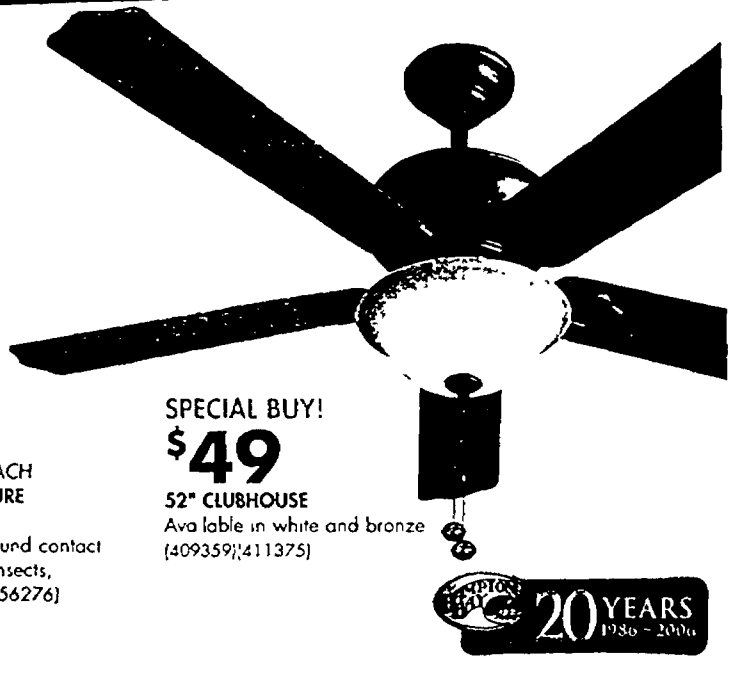

SPECIAL BUY!
\$49
 52" CLUBHOUSE
 Available in white and bronze
 (409359; 411375)



SPECIAL BUY!
\$69.98
 HUSKY 1-GALLON
 COMPRESSOR
 WITH 2-IN-1
 NAILER/STAPLER
 Ideal for inflation,
 stapling and brad
 nailing. (614624)

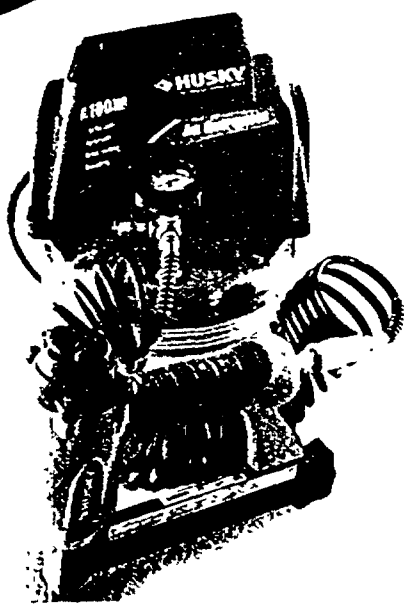

4 for \$10
 2 CU. FT.
 CYPRESS MULCH
 Adds organic material
 to soil. Helps insulate
 roots. (304549)

When purchased with The Home Depot Consumer Credit Card. Additional terms apply. See page 12 for key credit terms.
JULY 4TH: STORES CLOSE AT 8 P.M.

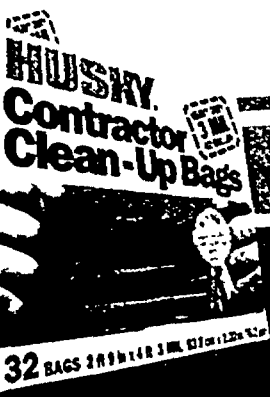
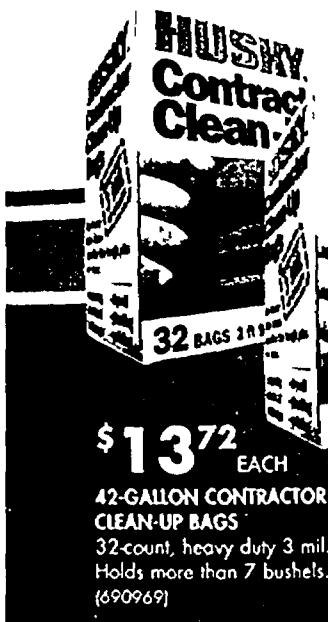

\$13.72 EACH
 42-GALLON CONTRACTOR
 CLEAN-UP BAGS
 32-count, heavy duty 3 mil.
 Holds more than 7 bushels.
 (690969)

99¢ EACH
 5/8"x5-1/2"-6'
 PRESSURE TREATED
 DOG-EARED FENCE PICKET
 Treated to resist insects, rot
 and decay. (169757)



SPECIAL BUY!
\$29.99 WAS \$39.99
 WORKFORCE™ 18" 5-SHELF
 VENTILATED STORAGE UNIT
 36"Wx72"Hx18"D. (625961)
 36"Wx72"Hx24"D. (902519) **\$39.99**



TORO

Incredibly versatile tractors at an incredible value. All models feature the Atach-a-Matic™ Hitch System, which allows you to mount a variety of attachments quickly and without tools.

2-YEAR FULL WARRANTY

\$299

ONLY \$13 PER MONTH*
6.5 HP 22" 3-IN-1 LOW WHEEL MOWER
Tecumseh GTS® engine, 3 in-1 rear bag, mulch and side discharge, Recycler™ cutting system with Atach-a-Matic blade. (436719)

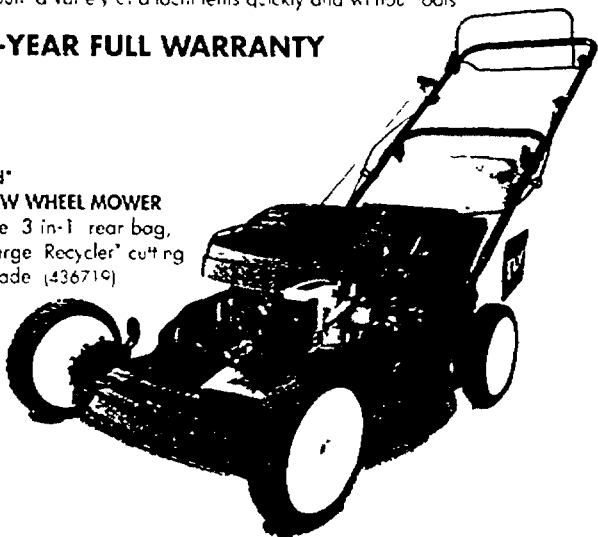

\$1299

ONLY \$37 PER MONTH*
18 HP, 42" TORO AUTODRIVE TRACTOR
6-HP Kohler™ Twin Cam OHV engine, Automatic CVT transmission with Cruise Control, 42" Manual PTO, 2 Blade Cutting Deck. (621466)



YARD MACHINES

Great features at the value you want for all your lawn mowing needs. Most models offer 2 in 1 capability, allowing you to mulch, bag or side discharge grass clippings.

2-YEAR LIMITED WARRANTY

\$139

4.5 HP, 22" 2-IN-1 SIDE DISCHARGE MOWER
Briggs & Stratton® engine, Recoil start system, 2 in 1 mulch and side discharge, optional bagger sold separately. (407875)



\$999

ONLY \$28 PER MONTH*
17.5 HP™, 42" YARD MACHINES®
7-SPEED LAWN TRACTOR
Briggs & Stratton® engine, 42" Twin-Blade Cutting Deck, 7-Speed Shift-On-The-Go™ transmission. (475728)
As rated by engine manufacturer.

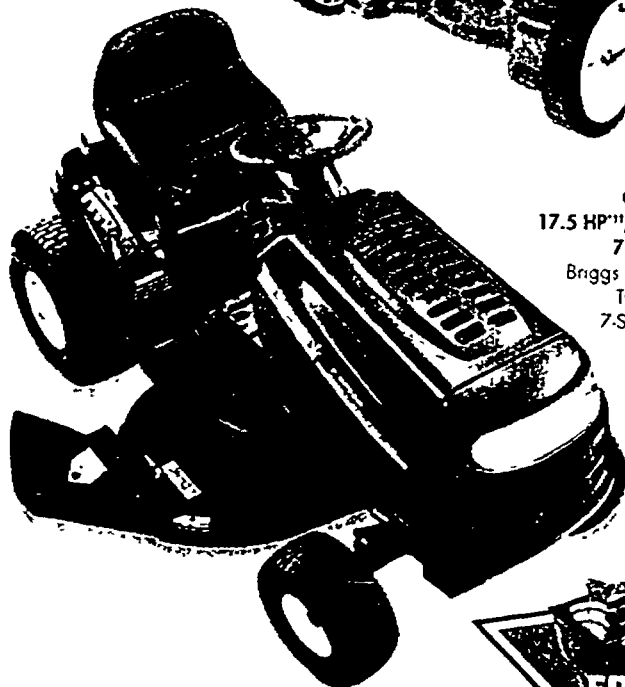

10% OFF ALL STRING TRIMMERS**



WAS \$79

HOMELITE 17" 25CC TRIM N' EDGE™ CURVED SHAFT GAS TRIMMER (440447)



BLACK & DECKER 24" ELECTRIC HEDGE HOG™ TRIMMER (499405)



\$89¹⁰

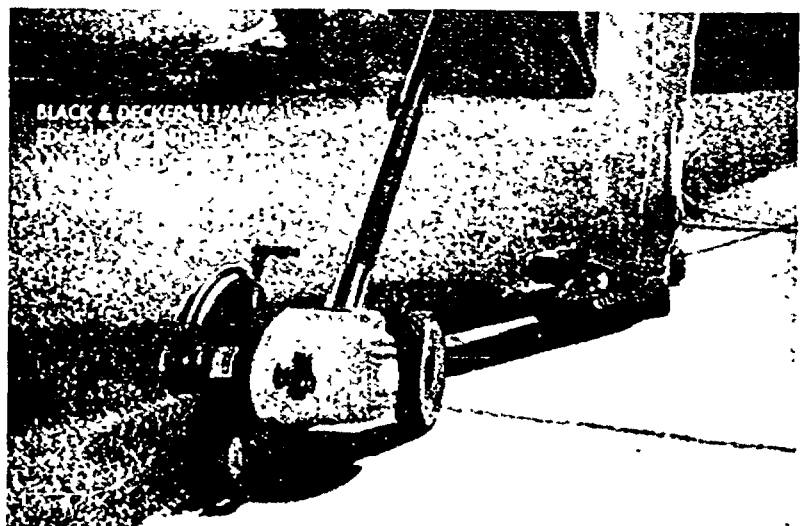

BLACK & DECKER 15 WATT BUG ZAPPER (727792)



\$64⁹⁷
BLACK FLAG PROPANE FOGGER. Dual action kills and repels. (541108)

\$199
AFTER \$25 MFR. MAIL-IN REBATE**
ONLY \$13 PER MONTH*
DEFENDER MOSQUITO MAGNET (220044)

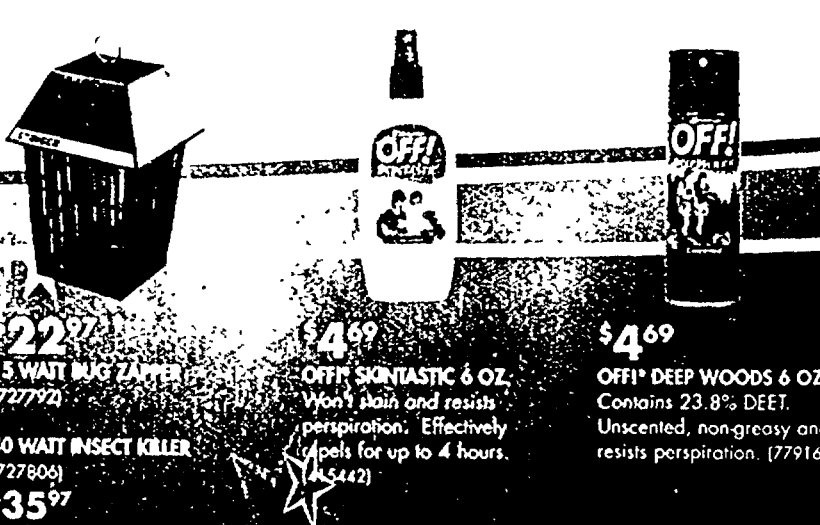

\$22⁹⁷
15 WATT BUG ZAPPER (727792)

\$35⁹⁷
40 WATT INSECT KILLER (727806)

\$4.69
OFF! SCENTASTIC 6 OZ. Won't stain and resists perspiration. Effectively repels for up to 4 hours. (45442)

\$4.69
OFF! DEEP WOODS 6 OZ. Contains 23.8% DEET. Unscented, non-greasy and resists perspiration. (779164)

YOU CAN DO IT. WE CAN HELP.™

May not be combined with any other rebate form. Must be purchased by 7/19/2006 and must be received at least by 8/2/2006. Valid 6/29/7/5/06 only at The Home Depot U.S. stores. Not valid on prior purchases, dealer and merchandise purchases of gift cards or services and may not be combined with any other offer or purchase a special rate program. See our offer release. Price as marked. Ask an associate for details. **Buy a Mosquito Magnet before 7/30/06 and save up to \$25 by Mail-in rebate. Some restrictions apply. See store or go to the link for details.

BRING ON THE SUN & FUN



Char-Broil
\$269

ONLY \$13 PER MONTH*
CHARBROIL® 48,000 BTU PERFORMANCE SERIES™ GAS GRILL WITH SIDE BURNER
 Exclusive patented PrecisionHeat™ cooking system. 675 sq. in. total cooking surface includes 195 sq. in. warming rack. 480 sq. in. primary cooking surface with porcelain cast iron grate. 13,000 BTU stainless steel sideburner. (132026)

Charmglow



\$399

ONLY \$17 PER MONTH*
CHARMGLOW™ 40,000 BTU STAINLESS STEEL GAS GRILL WITH SIDE BURNER (431915)

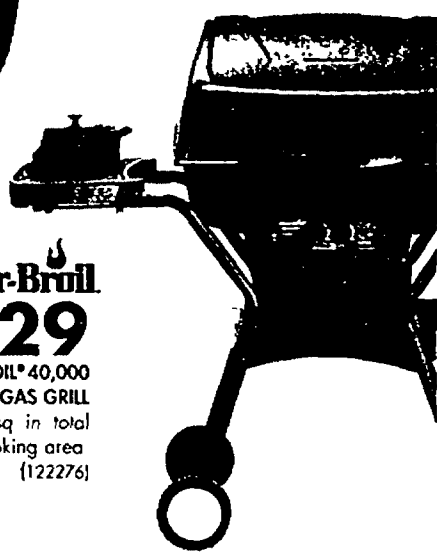

Char-Broil
\$129

CHARBROIL® 40,000 BTU GAS GRILL
 680 sq. in. total cooking area (122276)

VERMONT Castings

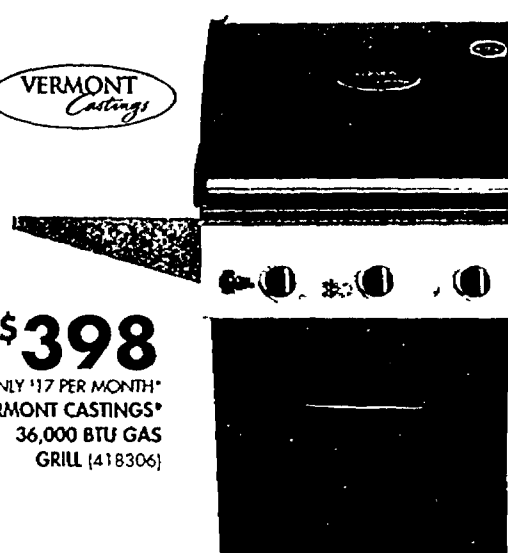

\$398

ONLY \$17 PER MONTH*
VERMONT CASTINGS® 36,000 BTU GAS GRILL (418306)

NEW LOWER RETAIL

\$179

ONLY \$10 PER MONTH*

MISSION BAY® 5-PIECE PATIO SET
 Combine 4 dining chairs and a glass tempered top rectangular dining table for a contemporary outdoor dining experience.

NEW LOWER RETAIL
MISSION BAY® DINING CHAIR (619810) \$31

NEW LOWER RETAIL
MISSION BAY® TABLE (895336) \$55

ALSO AVAILABLE

NEW LOWER RETAIL
MISSION BAY® 9' UMBRELLA (892792) \$79.20

NEW LOWER RETAIL
MISSION BAY® 9' UMBRELLA BASE (890274) \$27.98

NEW LOWER RETAIL
DECORATIVE PILLOWS STARTING AT \$10.36

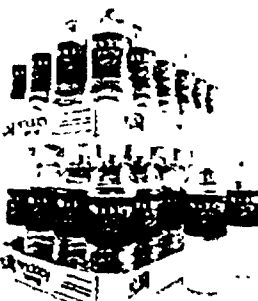
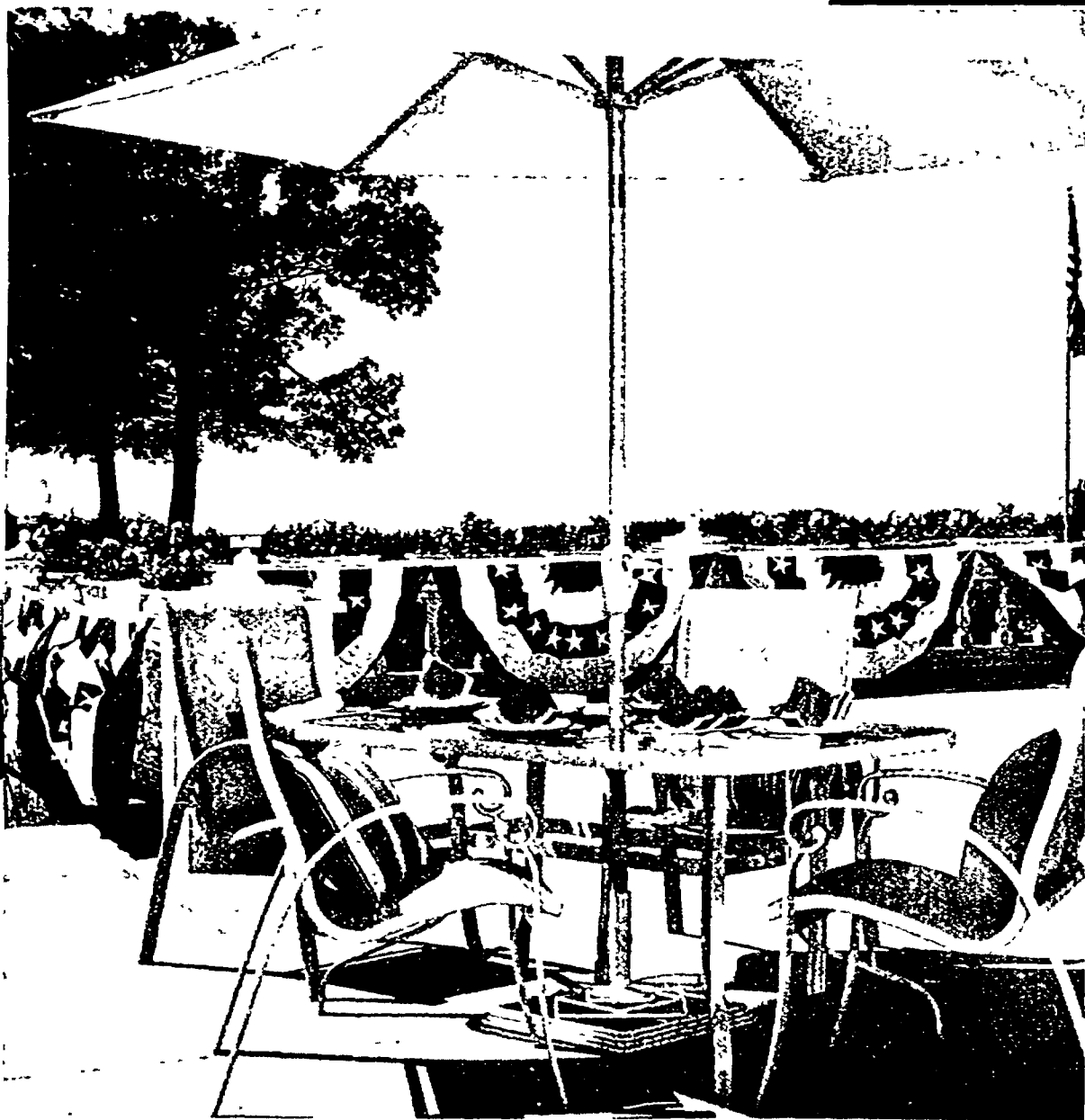

\$3.97 EACH

SPECIAL BUY 24-PACK 1/2 LITER HINCKLEY SPRINGS WATER (104433)(218340)



\$9.99
OFF!™ POWERPAD™ LAMP (312676)

OFF!™ POWERPAD™ LANTERN (313885) \$14.49



\$9.97
SUPER WATER CLARIFIER (402544)



\$79.96
POOLTIME™ 3" STABILIZED CHLORINATOR TABLETS 37.5 LBS. (286407)

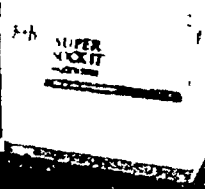

\$17.98
SUPER SHOCK, 5LBS BOX (288864)



\$2.99
10% ALGAE GUARD NON FOAMING (486183)

VERANDA

FREE \$50 GIFT CARD

Receive a \$50 THD gift card by mail-in rebate for every \$500 spent on Veranda products (includes fencing, decking and lattice). Qualifying total is based on pre-tax price. Offer valid on a single receipt purchase. Offer valid on purchases made between 6/22/06 and 7/5/06. Limit 10 per household. See rebate form for complete details.



VERANDA

COMPOSITE DECKING

Veranda is a composite material manufactured using wood fiber and resins. No need for restaining, waterproofing or sanding. Slate Gray (featured) is available in stock; Cascade Redwood, Tuscan Walnut or Buff Cedar colors available through special order. See store for details.

SIZE	8'	12'	16'
5/4"x6"	\$14 ⁹⁷	\$21 ⁹⁷	\$28 ⁹⁷



VERANDA

\$49⁹⁷

VERANDA® 6'X6' WINDHAM VINYL FENCE PANEL

Invest in long lasting results with low maintenance vinyl fencing. The never paint finish won't fade, peel or rust. (198354)

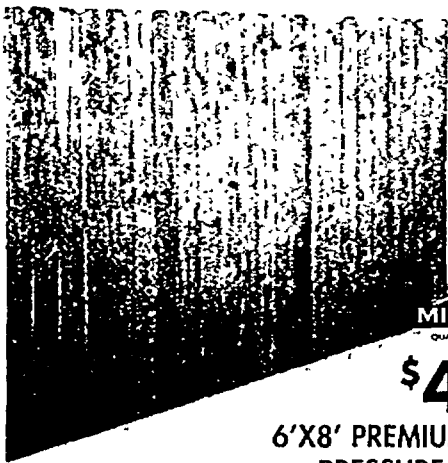

MILLSTEAD

\$43⁹⁷

6'X8' PREMIUM NO. 1 PRESSURE TREATED DOG-EARED FENCE PANEL

Durable 5/8"x6" pickets have been treated to resist insects, rot and decay includes three 2"x3" backer rails for stability. (647217)



MILLSTEAD Thompsonized WOOD

QUALITY YOU CAN SEE™

PRESSURE TREATED DECKING

A wood deck is aesthetically pleasing, economical and easy to maintain.

STANDARD PRESSURE TREATED DECKING

SIZE	8'	10'	12'	16'
5/4"x6"	\$4 ⁹⁷	\$5 ⁹⁷	\$7 ⁹⁷	\$13 ⁹⁷

THOMPSONIZED® PREMIUM TREATED DECKING

SIZE	8'	10'	12'	16'
5/4"x6"	\$7 ⁹⁷	\$8 ⁹⁷	\$11 ⁹⁷	\$15 ⁹⁷

TRIM & FINISH PROJECT BOARDS

We have the size and finish you need for any project. High strength, plus mill finish. It's all in one place. Just one stop to find the right board for your project.

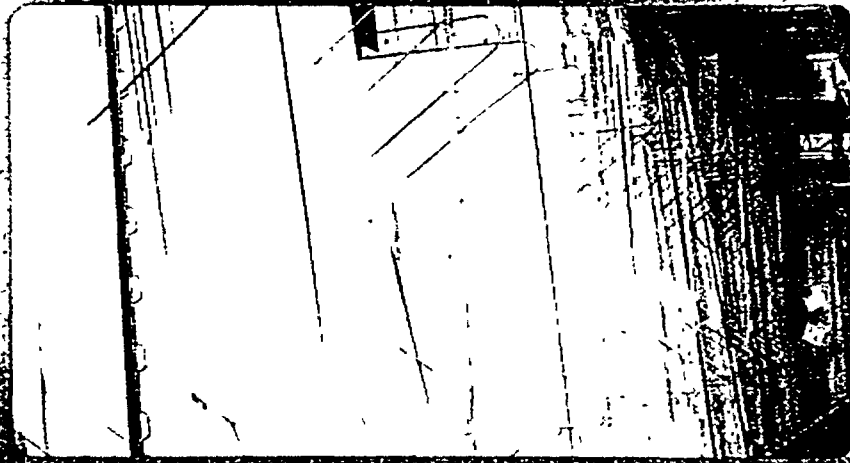

SPECIAL BUY

88¢ ea

1"X2"-8' FURRING STRIP

Used for hanging pegboard, paneling (160954)



SPECIAL BUY

99¢ ea

1"X4"-8' SUPER STRIP

Great project board. Smooth surface on all sides. (667642)



SPECIAL BUY

\$5⁹⁹ ea

1"X12"-8' PINE BOARD

Highline #2 grade. Smooth on four sides. Grade stamped. (445-535)

APPEARANCE GRADE PINE/SPRUCE BOARDS

Highline #2 grade. Smooth on four sides.

SIZE	6'	8'	10'	12'
1"x4"	\$2 ²⁵	\$2 ⁷⁷	\$3 ⁷⁵	\$4 ²⁹
1"x6"	\$3 ⁴⁸	\$4 ⁶⁴	\$5 ⁸⁰	\$6 ³⁹
1"x8"	\$5 ⁴⁹	\$6 ⁷⁵	\$8 ³⁹	\$9 ⁷⁹
1"x10"	\$6 ⁹⁸	\$9 ²⁵	\$10 ⁸⁸	\$13 ⁴⁹
1"x12"	\$8 ⁹⁹	\$5 ⁹⁹	\$13 ⁸⁸	\$15 ⁴⁸



CEDAR BOARD

Naturally resistant to insects, rot and decay. Great for any outdoor project.

SIZE	8'	12'
7/8"x2"	\$2 ⁹⁵	—
7/8"x4"	\$3 ⁹⁸	\$6 ²⁵
7/8"x6"	\$7 ⁸³	\$11 ⁷⁵
7/8"x8"	\$11 ⁹⁷	\$16 ⁹⁵



SELECT PINE BOARDS

SIZE	6'	8'
1"x2"	\$2 ⁷²	\$3 ⁵⁹
1"x4"	\$5 ²⁵	\$6 ⁸⁹
1"x6"	\$10 ⁵⁹	\$13 ⁹⁷
1"x8"	\$13 ²⁵	\$16 ⁹⁷



FURRING STRIP

Used for hanging pegboard, paneling. Smooth surface on all sides.

SIZE	8'	SIZE	8'
1"x2"	88¢	1"x4"	99¢
1"x3"	\$1 ⁵⁹	2"x2"	\$1 ⁸⁸



\$250

2 CU. FT. CYPRESS MULCH (304549)

\$469

2 CU. FT. NATURE SCAPES™ RED OR BLACK MULCH (647218) (356031)

\$13⁹⁷

3' X 50' VIGORO WEED CONTROL FABRIC (135593)

\$267

.5 CU. FT. MARBLE CHIPS WHITE (440943)

\$289

RIVER PEBBLES (440809)

Attention Lumber Customers: Prices in this ad may vary from the actual price at the time of purchase. We adjust our prices daily to the lumber commodity market. Post and post tops shown sold separately. Panels vary by store. Check location for special order or in-stock availability. Pricing stated is for panels and pickets only; professional installation is available for an additional charge.



SUMMER PROJECTS

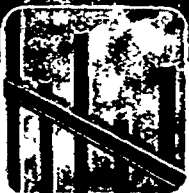

The Hawthorne

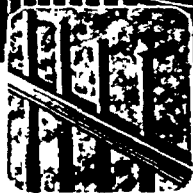

The Bismark



The Georgian



The Fremont

\$99

5'x8' GALVANIZED STEEL ORNAMENTAL FENCE PANEL

Create your ideal style with Master Hako 4 in 1 ornamental fencing. In the box, you'll find everything you need to assemble these four unique designs. Built with galvanized high tensile steel, plus a polyester powder-coat finish for superior corrosion resistance. (122933)

WALK GATE KIT (123189) **\$59**

NEW! EXCLUSIVE

\$2.95

NATURAL IMPRESSIONS FLAGSTONE CHARCOAL/TAN (280466)

\$2.75

FLAGSTONE CAP (283728)



\$6.34

20' RESIDENTIAL EDGING (627301)

60' (774421) **\$17.98**

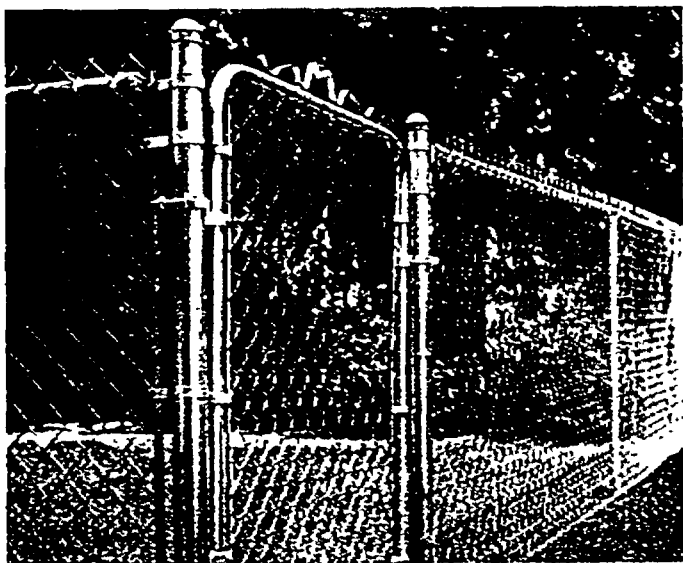

\$53.97

4'x50'

CHAIN-LINK FENCE

11-1/2 gauge, 2-3/8" mesh fabric galvanized for durability. Chain-link systems offer years of maintenance-free, long lasting protection. Easy to install. (373141)

6'x50' (551554) **\$79.97**



\$9.98

SPECIAL BUY 5 GAL. LATEX-ITE® SAND MIX DRIVEWAY SEALER/FILLER

Rubberized formula. Fills hairline cracks. 2 year warranty. Non-skid formula. (225580)

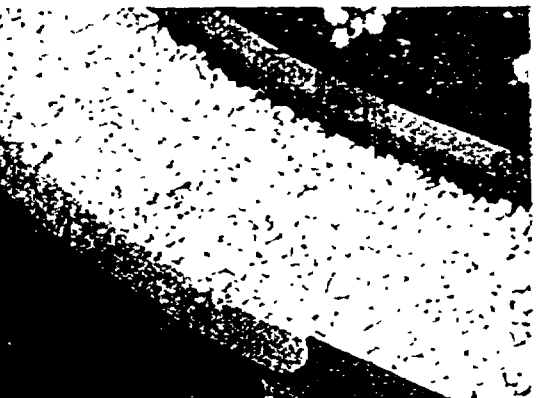

\$1.47

EA 12" EDGESTONE RED. Easy to install, durable and maintenance-free! (504216)



\$16.99

5 GAL. LATEX-ITE® AIRPORT GRADE II DRIVEWAY SEALER/FILLER. 4 Year Warranty. Recommended for any condition driveway. (332268)



\$22.99

5 GAL. LATEX-ITE® OPTIMUM PRO DRIVEWAY RE-SURFACER

Premium, no-stir formula. Recommended for all conditions on driveways but works especially well on driveways that have been sealed many times before. (225749)

\$13.99

18" LATEX-ITE® SEAL RIGHT™ DRIVEWAY SQUEEGEE

Contractor quality. Designed for driveway sealing. 60" wood handle. Reusable. (106997)

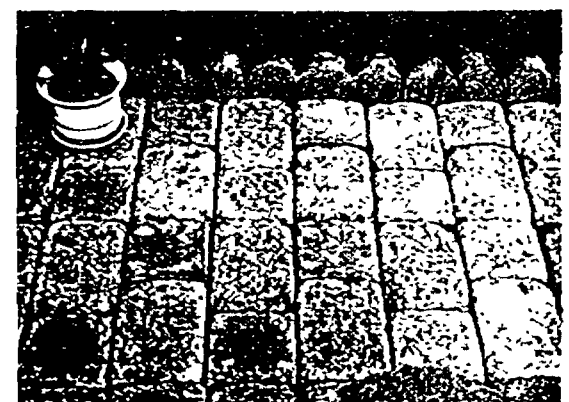

99¢

EA RECTANGLE TUMBLED PLAZA STONE (200571)

SQUARE PAVER (200905) **74¢**

G. R. LA LADDERS

SPECIAL BUY **\$9.99**

2-STEP SKIPPY MINI™ LADDER. 200 lb. capacity. Lightweight steel with wide steps and anti-slip feet. (417854)

STILLY

SPECIAL BUY **\$59**

8' ALUMINUM STEPLADDER WITH TRAY. 250 lb. capacity. Lightweight and extremely durable. (330920)

Louisville

SPECIAL BUY **\$89**

20' ALUMINUM EXTENSION LADDER. 225 lb. capacity. Ideal for painting and light maintenance. (597241)

Little Giant

\$359.80

ONLY \$17 PER MONTH! NEW! 17' ALUMINUM LITTLE GIANT LADDER SYSTEM* WITH WORK PLATFORM. 24 different ladders in one compact design. Now with wheels for easier portability. 300 lb. capacity. (579239) **\$399.80** 22' LITTLE GIANT (579919)

*When purchased with The Home Depot Consumer Credit Card. Additional terms apply. See pg. 12 for key credit terms. Due to daily market fluctuations, advertised prices may vary at time of purchase. Ornamental fencing available special order only in some stores. See store for details.

VISIT US ONLINE @HOMEDEPOT.COM

Andersen **AW**
Come home to Andersen.[®]



\$160

**SERIES 200 DOUBLE-HUNG
PRE-FINISHED WINDOW
WITH LOW-E GLASS**

Low-E glass. Pre-finished white interiors
Grilles sold separately. 2436 (238416)

SIZE	SKU	PRICE
2440	(238519)	\$175
2836	(238929)	\$171
2840	(238951)	\$184
3040	(239844)	\$194
3046	(181460)	\$209

**INSTALLATION
SERVICES**

**GUARANTEED
DOOR AND
WINDOW
INSTALLATION**

Our network of licensed professionals will take care of all the details so you don't have to. And we'll guarantee all work.

**DOORS: VISIT YOUR LOCAL STORE
WINDOWS: CALL 1-800-79-DEPOT
FOR A FREE IN-HOME CONSULTATION**

See page 12 for license numbers where applicable. See contact for general terms.

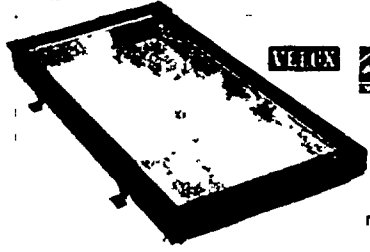

\$161

**FIXED SKYLIGHT
WITH LOW-E GLASS**

Premium wood construction with maintenance-free aluminum exterior. Skylight window coverings also available. 21-1/2"x46-3/8". FS106 (588175)

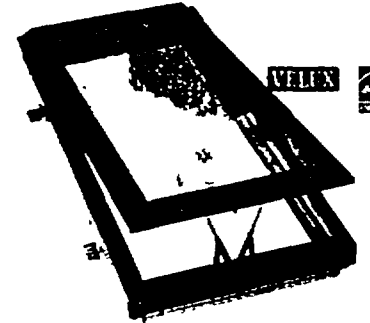

\$293

**VENTILATING SKYLIGHT
WITH LOW-E GLASS**

Tight, weatherproof close. Scissor operator for easy opening and maximum ventilation. 21-1/2"x38-1/2". VS104 (166522)



\$94

**SERIES 2900 SINGLE-HUNG VINYL
WINDOW WITH LOW-E GLASS**

Features Low-E glass for energy savings. Sash tilts in for easy cleaning. Low-maintenance vinyl never needs painting. Screen is included. Lifetime warranty. 2030 (828264)

SIZE	SKU	PRICE
2446	(828316)	\$117
3030	(828529)	\$107
3040	(828531)	\$124
3052	(828533)	\$140



\$140

**SERIES 3000 VINYL WINDOW
WITH LOW-E GLASS**

7/8" LoE2 insulated glass for comfort and year round savings. Impact resistant availability for coastal areas. ClearView™ Glass stays cleaner, longer. 2432 (623365)

SIZE	SKU	PRICE
24310	(623363)	\$148
28310	(279918)	\$155
2846	(623364)	\$165
3032	(623379)	\$154
3046	(623371)	\$172

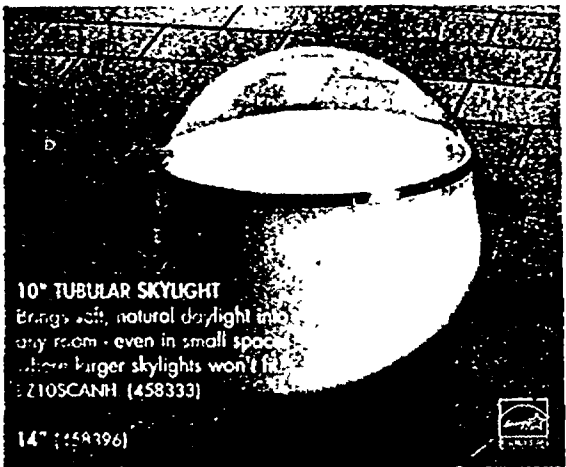

10" TUBULAR SKYLIGHT

Brings soft, natural daylight into any room - even in small spaces. Even larger skylights won't fit. 210SCANH (458333)

14" (458396)

ANDERSEN® STORM DOORS INSTALLED FOR ONLY \$57

OFFER VALID ON PURCHASES MADE BETWEEN 6/22/06 TO 7/12/06 ON THE BASIC INSTALLATION OF ANDERSEN BRANDED STORM DOORS ONLY!



Andersen **AW**
Come home to Andersen.[®]

\$298

**36" 4000 FULLVIEW
INSULATED WITH
NICKEL HARDWARE**

Full-length view for beauty and light. Glass and insect screen snap in/out. 1-1/2" thick heavy-gauge aluminum construction. Solid-brass or nickel hardware. (597004)



Andersen **AW**
Come home to Andersen.[®]

\$259

**36" 3000 TRUEEASE™
STORM DOOR WITH
NICKEL HARDWARE**

Easy one-hand operation. Unlimited window positioning. Innovative tilt wash windows for easy cleaning. Solid-brass or nickel-finish hardware. (237385)



Andersen **AW**
Come home to Andersen.[®]

\$239

**36" 3000 FULLVIEW
STORM DOOR
WITH ETCHED GLASS**

1-1/2" thick aluminum frame. Double Quad Seal weatherstrip seals out the weather. Deluxe solid brass handle and deadbolt built into door frame. Door holds in open position with touch of a button. (818104)

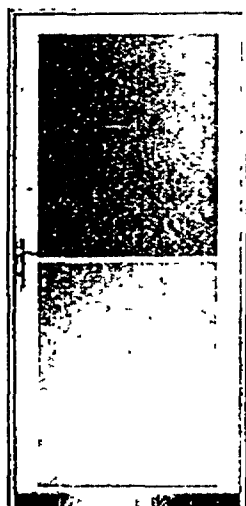

Andersen **AW**
Come home to Andersen.[®]

\$219

**36" 2000 SELF-STORING
STORM DOOR WITH
SLIDEAWAY™ SCREEN**

Exclusive SlideAway™ screen retracts into door frame and out of sight. Exclusive solid-brass FlipAway™ handle. Deadbolt and re-keyable lock are built into door frame. Door holds open with push of a button. Almond. (135062)

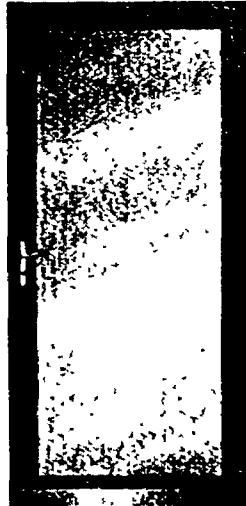

Andersen **AW**
Come home to Andersen.[®]

\$199

**36" 3000 FULLVIEW
STORM DOOR**

Deluxe solid-brass handle and deadbolt built into door frame. 1-1/2" thick aluminum frame with Double Quad Seal weatherstrip seals out the weather. Door holds in open position with touch of a button. Also available in white. (519987)

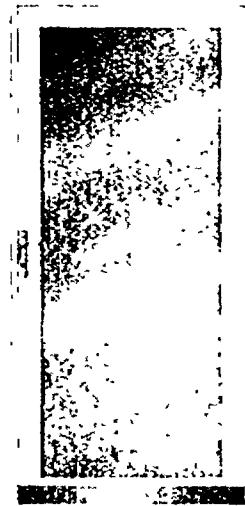

Andersen **AW**
Come home to Andersen.[®]

\$179

**32" OR 36" 2000
FULLVIEW STORM DOOR**

1-1/4" thick aluminum construction. Glass and insect screen snap in and out. Guaranteed for as long as you own your home. (818215)(818271)



\$129

**36" RETRACTABLE
SCREEN DOOR**

Screen retracts when not in use to provide a clear, unobstructed view. (172502)



\$74.94

**32" OR 36"
QUARTER PANEL
VINYL SCREEN DOOR
WITH HARDWARE**

Top quality fiberglass screening. (515985)(516121)



\$49.88

**32" OR 36" CENTURY
SCREEN DOOR**

Solid wood with charcoal fiberglass screen. Ready to finish. Hardware sold separately. (213608)(203205)



\$19.98

**30", 32" OR 36" T-BAR
WOOD SCREEN DOOR**

Solid wood with charcoal fiberglass screen. Ready to finish. (424957)(424697)(702062)



FREE MultiTASKit LASER™



\$229
ONLY \$10 PER MONTH*
18-VOLT 7-PIECE RENOVATOR COMBO
WITH TORQUE IV™ DRILL (167144)

PURCHASE ANY RYOBI ONE+ COMBO KIT AND MultiTASKit AND RECEIVE THE MultiTASKit FREE™
AFTER \$49 MAIL IN REBATE

\$278⁹⁷ total of combo kit and laser level
-\$49⁹⁷ via mail-in rebate**

\$229 after mail-in rebate

\$49⁹⁷
MultiTASKit LASER (292060)

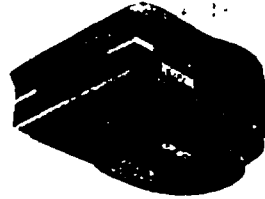

5 TOOLS-IN-1



\$69⁹⁷
IMPACT DRIVER (725680)



NO PAYMENTS, NO INTEREST FOR 12 MONTHS

ON ANY PURCHASE OF \$299 OR MORE MADE ON THE HOME DEPOT CONSUMER CREDIT CARD 6/29 THROUGH 7/5/06



\$99
YOUR CHOICE
10" COMPOUND MITER SAW (179469)
10" TABLE SAW WITH STAND (418826)



\$99⁹⁷
MITER SAW STAND
Use with most miter saws up to 12" (446334)



\$199 was \$229
RYOBI™ 12" COMPOUND MITER SAW WITH LASER (203485)

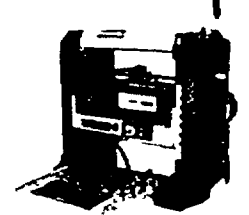

\$199
13" SURFACE PLANER
15 AMP motor with externally accessible brushes (348277)

SKIL
HURRY! GOOD THROUGH 7/5



\$20
RECEIVE A GIFT CARD TO THE HOME DEPOT by mail-in rebate with select Skil® tools**



\$79
YOUR CHOICE
JIGSAW WITH LASER AND LIGHT
5.0 AMP motor, no load SPM;
800-3,200 SPM (382197)

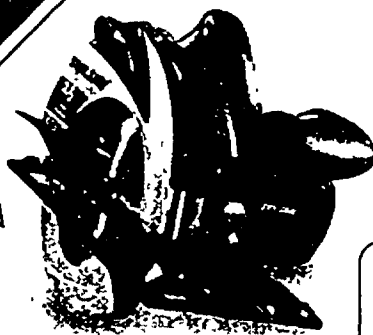

\$79
YOUR CHOICE
SKILSAW™ WITH LASER
7-1/4", 13.0 AMP motor,
4,600 RPM (382238)



\$79 was No Match!
18-VOLT SITELIGHT™ DRILL KIT
Built-in Sritelight™ for better visibility and accuracy (410680)

AS SEEN ON FOX AND FRIENDS
\$39
IXO 3.6 LITHIUM-ION SCREWDRIVER Ready to go- holds charge up to 18 months (611003)

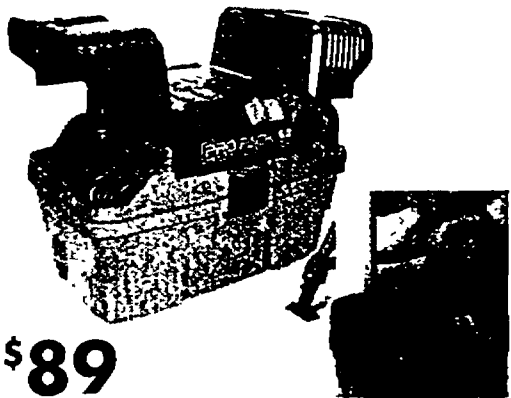

\$89
4 GALLON 4 PEAK HP PRO PACK WET/DRY VAC Compact, light and portable 15.5 hp unit is easily stacked and stored (439571)

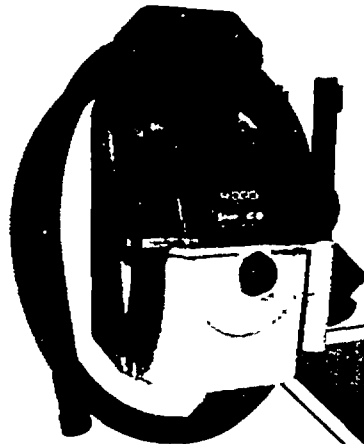

\$99
5-GALLON 5 PEAK HP STOR-N-GO CLEANING STATION Vac mounts out of the way on the wall and organizes cord and hoses on-board (439523)

16-GALLON 6.5 PEAK HP 2-IN-1™ WET/DRY VAC WITH DETACHABLE BLOWER Dual function vac can be used as wet/dry vac or hand held yard blower Exclusive Microban™ treated filter (223380)



INCREDIBLE VALUE!

\$299 special buy price
-\$20 via mail-in rebate**

\$279 after mail-in rebate

ONLY \$13 PER MONTH*
SPECIAL BUY 3-NAILER/COMPRESSOR COMBO KIT (222516)

110Per valid 6/29/06 through 8/30/06 by mail-in rebate on a single receipt purchase of a Porter Cable Three Nailer Combo Kit (aka 222516 model C19CS317) A \$20 rebate will be given for each qualifying product purchased and submitted that meets offer requirements. No credit if after refund. May not be combined with any other offer. See offer form at homedepot.com for complete details.

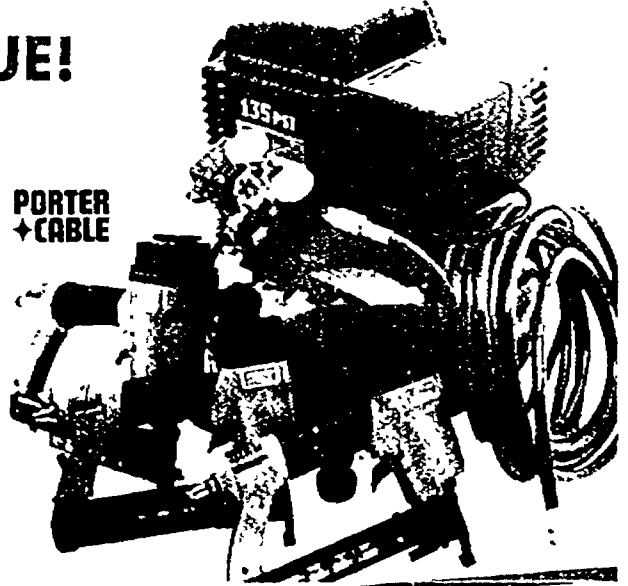

BOSTITCH
\$289 everyday low price
-\$50 via mail-in rebate**

\$239 after mail-in rebate
ONLY \$10 PER MONTH*
COILED ROOFING NAILER (751916)



\$19⁹⁶
STANLEY™ 25' 1-1/4" FATMAX TAPE MEASURE (655095)
30' (796978) **\$24⁹⁵**
35' (215880) **\$28⁹⁹**



\$7⁶⁷
IRWIN™ 100' CHALK AND REEL WITH BONUS LEVEL RED (117350)
BLUE (142778)



\$25⁶⁸
ESTWING™ 22 OZ. FRAMING HAMMER WITH MILLED FACE (284858)
SMOOTH FACE (138444) **\$25⁸⁶**



\$8⁴³
STANLEY™ INSTANT CHANGE KNIFE Contractor grade (423123)

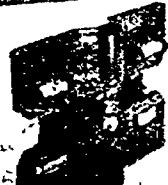

\$5⁴⁹
HUSKY™ POSTRITE POST LEVEL For posts, pipes and signs (378675)



\$19⁸⁶
PROJECT CALC™ PLUS CALCULATOR Project calculator with advanced features (773358)



BIG PAINT EVENT

**HURRY IN!
ENDS TUESDAY!**

\$6 OFF

\$25 OFF

1-GALLON CANS**
BY MFR. MAIL-IN REBATE**

5-GALLON CANS**
BY MFR. MAIL-IN REBATE**

ALL BEHR PREMIUM PLUS INTERIOR /EXTERIOR PAINT,
BULLS EYE 1-2-3* AND THOMPSON'S* WATERSEAL ADVANCED

HunterDouglas
STYLE & DESIGN
COLLECTION
10% OFF
ALL CUSTOM BLINDS STYLES BY
HUNTER DOUGLAS* PLUS FREE SHIPPING



**SAVE ON ALL THE LATEST
COLORS AND STYLES FOR
EVERY DECOR**

- Duette* and Applause* honeycomb shades
- Silhouette*, Vignette* and Nantucket* sheer shadings
- Woven Wood, Country Woods and Faux Wood blinds
- Verticals and Aluminum blinds and Roman Shades

Offer valid 6/29/2006 - 8/3/2006 on the purchase of Hunter Douglas Style & Design Collection special order window treatments. Offer valid in U.S. The Home Depot stores only. Financing cannot be combined with any other offer, and is valid on special order product only. Discount does not apply to in-stock product or installation services, or on prior purchases. No credit if offer refused. See store associate for complete details.



**VOTED #1
3 YEARS
IN A ROW!**
by an independent
national study

**BRIGHTEN YOUR ROOM
WITH INTERIOR PAINT**

- Lifetime guarantee
- Superior quality made from the finest materials available
- Easy stain removal without heavy scrubbing



**ADD A FRESH COAT TO
YOUR HOME'S EXTERIOR**

- Lifetime guarantee
- Mildew and fade resistant
- Protects and shields against moisture



**THE FIRST STEP FOR ANY
PAINTING PROJECT - PRIMER**

- Stain killing sealer primer offers excellent adhesion
- Acrylic formula resists blistering and peeling
- Easy to apply

*Voted #1 in a row for 3 years in a row by an independent national study. See store associate for complete details. ZINSSER and BEHR offers valid 6/29 - 7/4/06 and rebate requests must be received no later than 8/4/06. BEHR valid on purchase of BEHR interior and exterior paint and primer, decorative finishes, waterproofer and stains in U.S. and Puerto Rico The Home Depot stores only. Not valid on Ooops or returned paint. No returns without UPC. THOMPSON'S Water Seal 6/29 - 7/3 and rebate requests must be received by 8/13/06. Does not include Thompson's WaterSeal products.



PROTECT YOUR DECK

- Applies to damp, freshly cleaned wood
- Maximum strength protection against water damage
- Coating resists mildew and UV damage



HUSKY.

\$225 WAS \$299

**HUSKY® 2200 PSI
GAS PRESSURE WASHER**
Fully enclosed design
4.5 HP Briggs & Stratton
SQ (side valve, vertical shaft)
engine 2.0 GPM Telescopic
handle 4 quick connect nozzles
Top panel accessory & detergent
storage (502084)

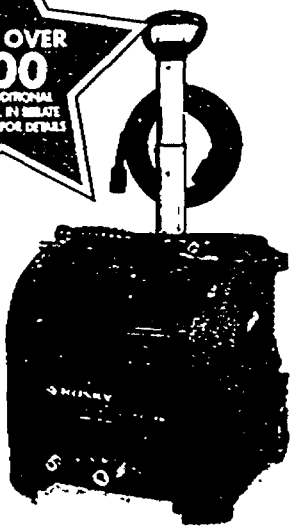

HUSKY.

\$199 WAS \$269

**HUSKY® 2200 PSI
GAS PRESSURE WASHER**
4.5 HP Briggs & Stratton
SQ engine (side valve,
vertical shaft) 2.0 GPM
Telescopic handle with 3
quick connect nozzles
Mesh bag for hose,
trigger gun and wand
(629735)



\$699
DEWALT® 2800 PSI PRESSURE WASHER
Honda GX200 engine 3.0 GPM 6.5 HP
123595)

**\$70 IN FREE
ACCESSORIES**
RECEIVE A \$70 WORTH OF
HOSE OR A \$70
PROTECTION PACKAGE
by mail-in rebate**

Powered by
**HONDA
ENGINES**
DEWALT

335.738.200 400.408.448.10.15.16.17.18.19.20.21.22.23.24.25.26.27.28.29.30.31.32.33.34.35.36.37.38.39.40.41.42.43.44.45.46.47.48.49.50.51.52.53.54.55.56.57.58.59.60.61.62.63.64.65.66.67.68.69.70.71.72.73.74.75.76.77.78.79.80.81.82.83.84.85.86.87.88.89.90.91.92.93.94.95.96.97.98.99.100.101.102.103.104.105.106.107.108.109.110.111.112.113.114.115.116.117.118.119.120.121.122.123.124.125.126.127.128.129.130.131.132.133.134.135.136.137.138.139.140.141.142.143.144.145.146.147.148.149.150.151.152.153.154.155.156.157.158.159.160.161.162.163.164.165.166.167.168.169.170.171.172.173.174.175.176.177.178.179.180.181.182.183.184.185.186.187.188.189.190.191.192.193.194.195.196.197.198.199.200.201.202.203.204.205.206.207.208.209.210.211.212.213.214.215.216.217.218.219.220.221.222.223.224.225.226.227.228.229.230.231.232.233.234.235.236.237.238.239.240.241.242.243.244.245.246.247.248.249.250.251.252.253.254.255.256.257.258.259.260.261.262.263.264.265.266.267.268.269.270.271.272.273.274.275.276.277.278.279.280.281.282.283.284.285.286.287.288.289.290.291.292.293.294.295.296.297.298.299.300.301.302.303.304.305.306.307.308.309.310.311.312.313.314.315.316.317.318.319.320.321.322.323.324.325.326.327.328.329.330.331.332.333.334.335.336.337.338.339.340.341.342.343.344.345.346.347.348.349.350.351.352.353.354.355.356.357.358.359.360.361.362.363.364.365.366.367.368.369.370.371.372.373.374.375.376.377.378.379.380.381.382.383.384.385.386.387.388.389.390.391.392.393.394.395.396.397.398.399.400.401.402.403.404.405.406.407.408.409.410.411.412.413.414.415.416.417.418.419.420.421.422.423.424.425.426.427.428.429.430.431.432.433.434.435.436.437.438.439.440.441.442.443.444.445.446.447.448.449.450.451.452.453.454.455.456.457.458.459.460.461.462.463.464.465.466.467.468.469.470.471.472.473.474.475.476.477.478.479.480.481.482.483.484.485.486.487.488.489.490.491.492.493.494.495.496.497.498.499.500.501.502.503.504.505.506.507.508.509.510.511.512.513.514.515.516.517.518.519.520.521.522.523.524.525.526.527.528.529.530.531.532.533.534.535.536.537.538.539.540.541.542.543.544.545.546.547.548.549.550.551.552.553.554.555.556.557.558.559.560.561.562.563.564.565.566.567.568.569.570.571.572.573.574.575.576.577.578.579.580.581.582.583.584.585.586.587.588.589.590.591.592.593.594.595.596.597.598.599.600.601.602.603.604.605.606.607.608.609.610.611.612.613.614.615.616.617.618.619.620.621.622.623.624.625.626.627.628.629.630.631.632.633.634.635.636.637.638.639.640.641.642.643.644.645.646.647.648.649.650.651.652.653.654.655.656.657.658.659.660.661.662.663.664.665.666.667.668.669.670.671.672.673.674.675.676.677.678.679.680.681.682.683.684.685.686.687.688.689.690.691.692.693.694.695.696.697.698.699.700.701.702.703.704.705.706.707.708.709.710.711.712.713.714.715.716.717.718.719.720.721.722.723.724.725.726.727.728.729.730.731.732.733.734.735.736.737.738.739.740.741.742.743.744.745.746.747.748.749.750.751.752.753.754.755.756.757.758.759.760.761.762.763.764.765.766.767.768.769.770.771.772.773.774.775.776.777.778.779.780.781.782.783.784.785.786.787.788.789.790.791.792.793.794.795.796.797.798.799.800.801.802.803.804.805.806.807.808.809.810.811.812.813.814.815.816.817.818.819.820.821.822.823.824.825.826.827.828.829.830.831.832.833.834.835.836.837.838.839.840.841.842.843.844.845.846.847.848.849.850.851.852.853.854.855.856.857.858.859.860.861.862.863.864.865.866.867.868.869.870.871.872.873.874.875.876.877.878.879.880.881.882.883.884.885.886.887.888.889.890.891.892.893.894.895.896.897.898.899.900.901.902.903.904.905.906.907.908.909.910.911.912.913.914.915.916.917.918.919.920.921.922.923.924.925.926.927.928.929.930.931.932.933.934.935.936.937.938.939.940.941.942.943.944.945.946.947.948.949.950.951.952.953.954.955.956.957.958.959.960.961.962.963.964.965.966.967.968.969.970.971.972.973.974.975.976.977.978.979.980.981.982.983.984.985.986.987.988.989.990.991.992.993.994.995.996.997.998.999.1000.



\$6.97 EACH
**3M® 2" LONG-MASK
MASKING TAPE**
(315026)

\$9.99 EACH
8-PIECE PAINT SET*
(530803)

SPECIAL BUY!
\$3.88 WAS \$4.99
5'6" x 7'6" TARP
Rust-proof aluminum grommets.
5 mil. (750174)

\$7.97 EACH
**DAMPRIID® HOUSE WASH
OR DECK WASH**
(611298, 611301)

\$5 OFF GAL
**RUST-OLEUM PROFESSIONAL
GLOSS BLACK & WHITE**
BY MFR. MAIL-IN REBATE



*Paint \$5.00 on 1 gallon of Rust-Oleum Professional Gloss Black or White. See store associate for complete details. Offer valid on purchase of 1 gallon of Rust-Oleum Professional Gloss Black or White. Offer valid in U.S. and Puerto Rico. See store associate for complete details.



YOU CAN DO IT. WE CAN HELP.™

When purchased with The Home Depot Consumer Credit Card. Additional terms apply. See page 12 for key credit terms.

NOBODY BEATS OUR PRICES

INSTALLATION SERVICES

NOBODY INSTALLS MORE FLOORING

Create your new look without lifting a finger. Our network of licensed professionals will install your flooring the right way, right away. Plus, all work is guaranteed by The Home Depot.*

- Dedicated Project Managers
- 11,000 flooring options
- Exclusive brands like StainMaster Platinum Plus & Dupont RealTouch Elite

START TODAY: VISIT YOUR LOCAL STORE

FIND THE RIGHT STYLE, AT GUARANTEED LOW PRICES.♦

WOOD FLOORING

For natural beauty and durability, there's nothing like hardwood. Rich, warm tones and easy care produce a classic flooring that will never go out of style.

\$1.97 SQ. FT.
TRAFFICMASTER™ VALLEY OAK WOOD
 Engineered wood flooring. Case covers 26.16 sq. ft.
 (578350)

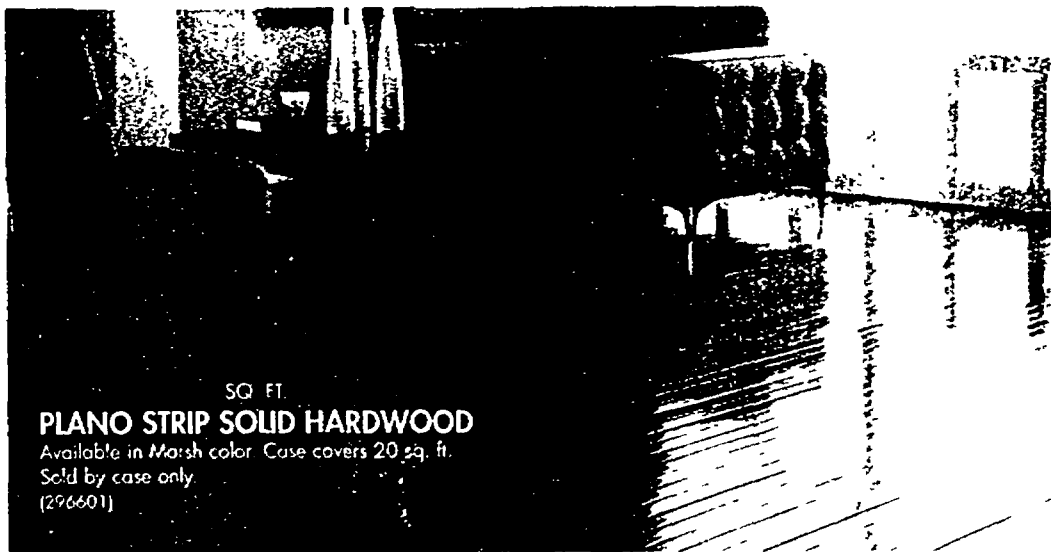
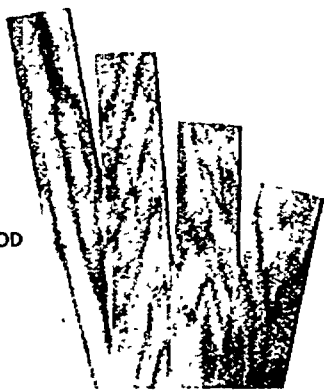

\$5.99 SQ. FT.
PLANO STRIP SOLID HARDWOOD
 Available in Marsh color. Case covers 20 sq. ft.
 Sold by case only.
 (296601)

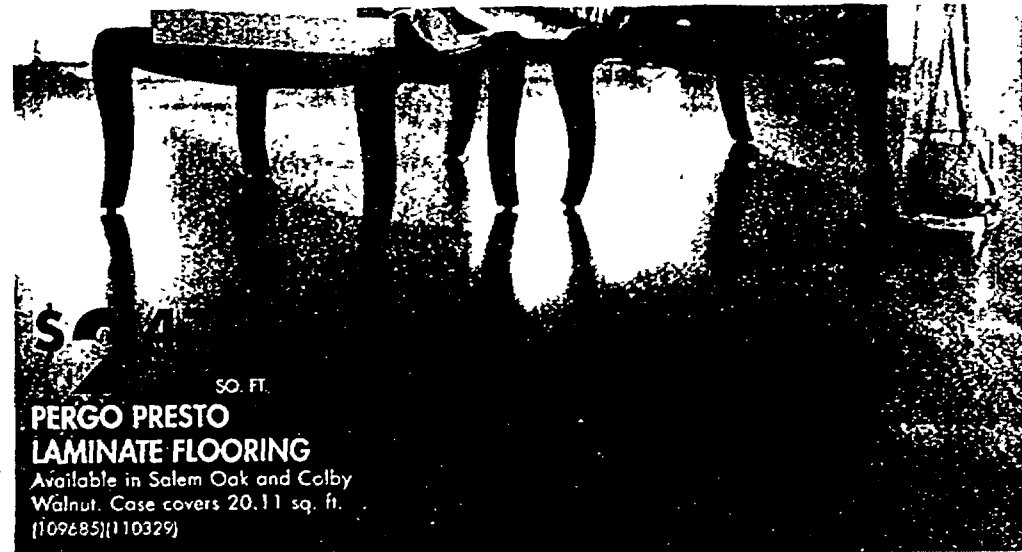

\$2.99 SQ. FT.
PERGO PRESTO LAMINATE FLOORING
 Available in Salem Oak and Colby Walnut. Case covers 20.11 sq. ft.
 (109685)|(110329)

LAMINATE FLOORING

Get the look of real wood, tile, or stone floors at a fraction of the price. A durable and low maintenance product that can be installed virtually anywhere.

97¢ SQ. FT.
TRAFFICMASTER™ RIO LAMINATE FLOORING
 Case covers 23.77 sq. ft.
 (594572)

97¢ SQ. FT.
TRAFFICMASTER™ BRASILIA LAMINATE FLOORING
 Case covers 23.77 sq. ft.
 (594532)

TILE FLOORING

Beyond its beauty, ceramic or natural stone tile is also durable, making it an excellent floor covering for high traffic areas of your home.

\$1.96 SQ. FT.
12"x12" ANTICA SPAGNA
 Case covers 15 sq. ft.
 (456159)|(456167)

\$2.75 SQ. FT.
12"x12" GOLDEN NUGGET MOSAIC
 Case covers 10 sq. ft.
 (456192)|(456127)

\$1.99 SQ. FT.
12"x12" MT. EVEREST VERDE
 Case covers 14.53 sq. ft.
 (353728)|(353760)

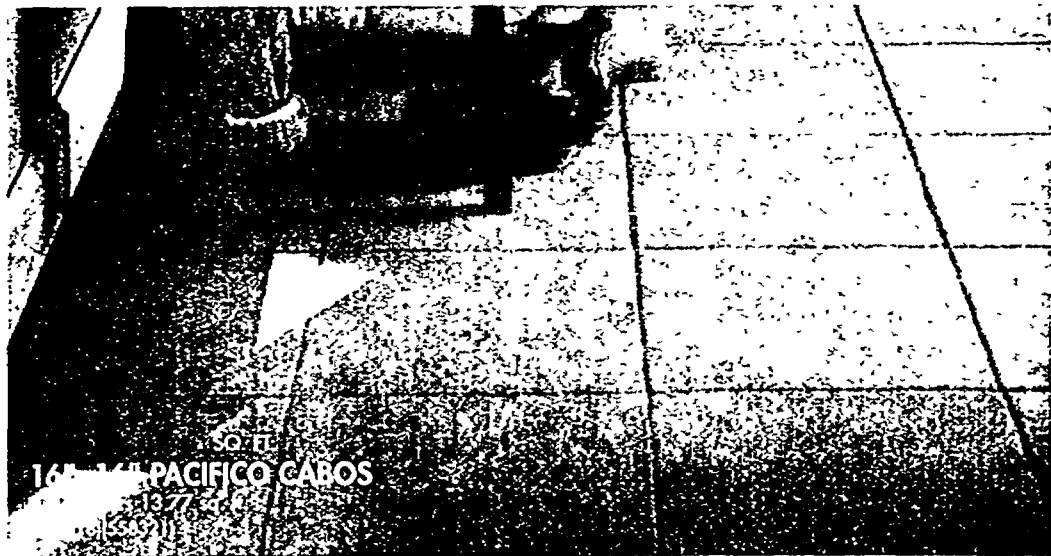

\$3.99 SQ. FT.
16"x16" PACIFICO CABOS
 Case covers 13.77 sq. ft.
 (456153)|(456151)

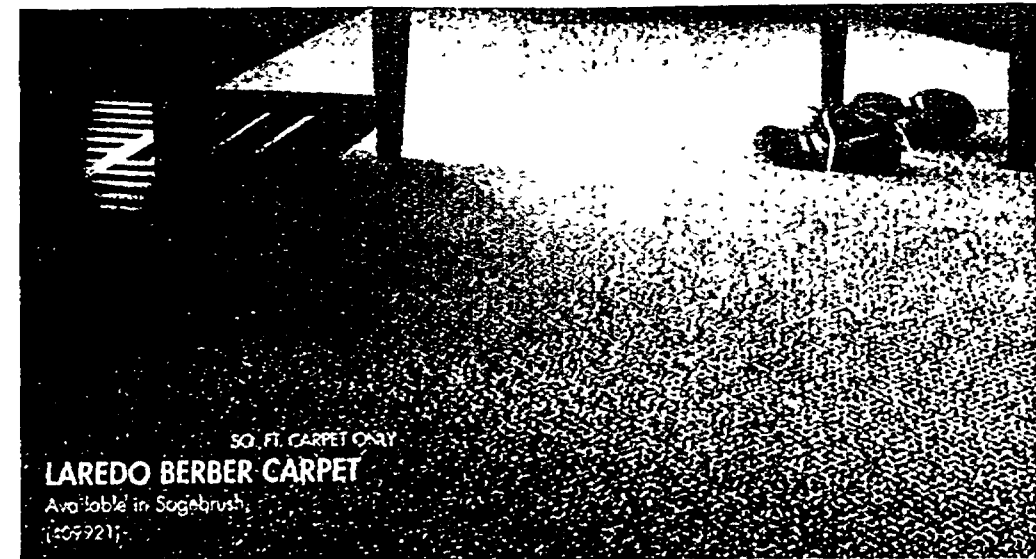

\$2.99 SQ. FT. CARPET ONLY
LAREDO BERBER CARPET
 Available in Sagebrush.
 (409921)

CARPET

Affordable, comfortable and available in hundreds of styles and colors to match any decor, carpet makes the perfect choice for any room in your home.

65¢ SQ. FT. CARPET ONLY
TORRENT TEXTURE CARPET
 Available in a warm beige color. (372569)

47¢ SQ. FT. CARPET ONLY
BEAULIEU™ 12' PERFECTION PARADISE INDOOR/OUTDOOR CARPET
 3 year wear warranty. Easy to install. (591554)



\$2.74 WAS \$3.49 SQ. FT.
12"x12" CONTINENTAL SLATE PORCELAIN TILE
 Case covers 14.53 sq. ft.
 Special order. (199155)

\$5.19 WAS \$6.99 SQ. FT.
12"x12" ABSOLUTE BLACK GRANITE
 Case covers 5 sq. ft.
 Special order. (245137)

\$2.75 WAS \$3.49 SQ. FT.
12"x12" TAJAH TILE
 Case covers 11 sq. ft.
 Special order. (199155)

*Valid for 20% off on purchases of special order ceramic, porcelain and stone tile from 5/25/2006 - 7/12/2006. Available only at US The Home Depot stores including Alaska and Hawaii. Not valid on any in-stock merchandise. Installation not included. Does not apply to retail tile. Not valid at Expo Design Centers. (See page 12 for license numbers. See contract for guarantee details. ♦See page 12 for guarantee details.

VISIT US ONLINE @HOMEDEPOT.COM



LG FRONT LOAD WASHER AND DRYER

Large capacity drum SenseClean Sensor Dry Stackable units
WM1814CW (Depot Direct 140493) DLE2514W (Depot Direct 143586)
*For details please visit us at www.lg.com

WASHER

\$799 PLUS \$50 MAIL-IN REBATE*
ONLY \$23 PER MONTH*

DRYER

\$649 PLUS \$50 MAIL-IN REBATE*
ONLY \$19 PER MONTH*

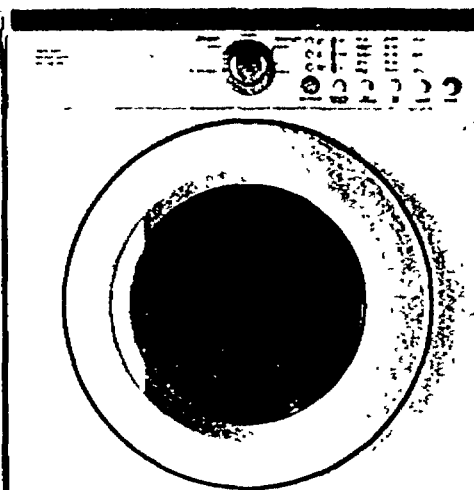
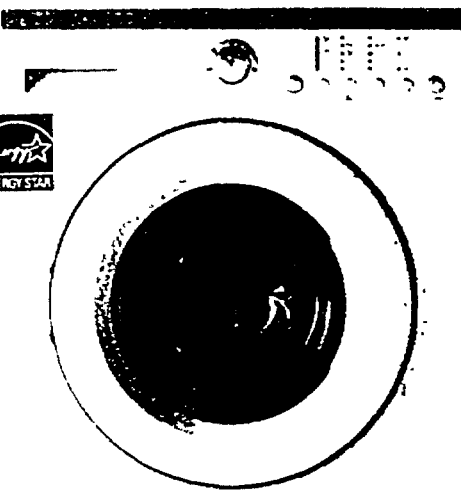

EXCLUSIVE
SUPER CAPACITY WASHER AND EXTRA LARGE DRYER
Single action agitator 2 speed combinations Auto Dry
DuraDrum™ QuietByDesign™
(155570, Depot Direct 326177)
(575292, Depot Direct 561986)

WASHER
\$279
ONLY \$13 PER MONTH*

DRYER
\$259
ONLY \$13 PER MONTH*

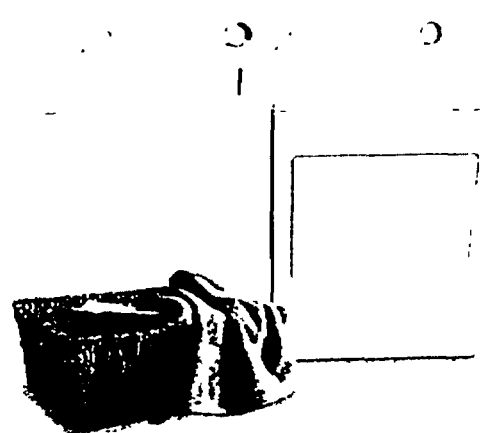

EXCLUSIVE
MAYTAG® LEGACY™ WASHER AND DRYER
GentleBreezy™ wash system Loadflex™ agitator
DenimBreeze™ drying system Automatic dryness sensor
MAV208DAWW (513769, Depot Direct 514201)
MDE308DAYW (513787, Depot Direct 514302)

WASHER
\$399
ONLY \$17 PER MONTH*

DRYER
\$369
ONLY \$17 PER MONTH*

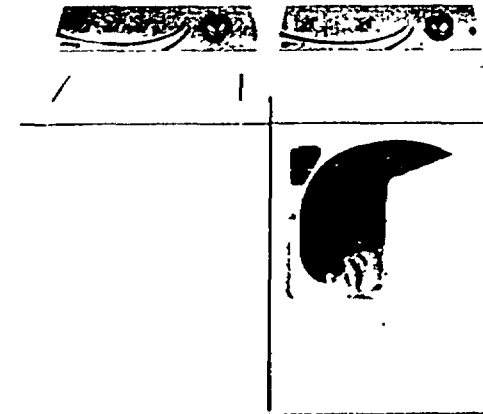

10% OFF ALL APPLIANCES**

PRICES SHOWN DO NOT REFLECT DISCOUNT. DISCOUNT TAKEN AT REGISTER.

HOTPOINT

\$239 ONLY \$10 PER MONTH*
HOTPOINT® BUILT-IN DISHWASHER
QuietPower™ motor Power Wash II system
Hot prewash option
HDA3400EWW (265405, Depot Direct 446097)
*Stainless steel available at additional cost

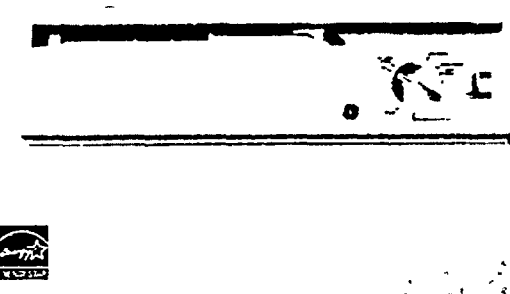

\$399 ONLY \$17 PER MONTH*
EXCLUSIVE MAYTAG® LEGACY™ SERIES DISHWASHER
Super large capacity Multiple, self-cleaning filtration system Microprocessor controls with 10 touch pads
MDBH955AWW (627879, Depot Direct 563979)
*Stainless steel available at additional cost

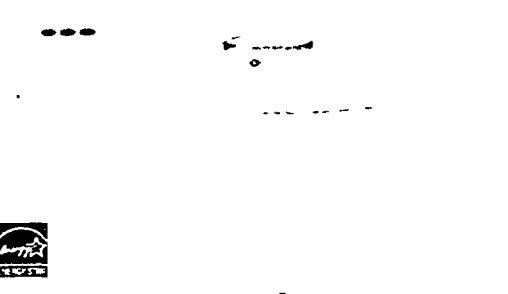

\$849 ONLY \$23 PER MONTH*
PLUS \$50 MAIL-IN REBATE*
LG STAINLESS STEEL DISHWASHER
Stainless steel XL tub Design-A-Rack™ system
LoDecibel™ quiet operation SenseClean™ wash system
LDF6810ST (Depot Direct 415864)



HOTPOINT

\$349 ONLY \$13 PER MONTH*
HOTPOINT® SELF-CLEANING ELECTRIC RANGE
Super large oven capacity Standard window
Frameless glass oven door Porcelain cooktop
FB757.WHWW (550090, Depot Direct 343632)

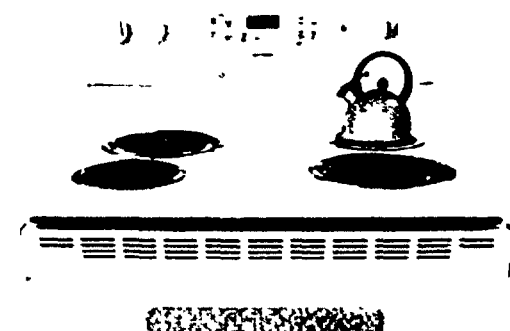

HOTPOINT

\$499 ONLY \$16 PER MONTH*
HOTPOINT® 30" SELF-CLEANING GAS RANGE
Extra large oven capacity Sealed cooktop burners
Easy Set III controls Frameless oven door
RGB745WEHWW (Depot Direct 138867)

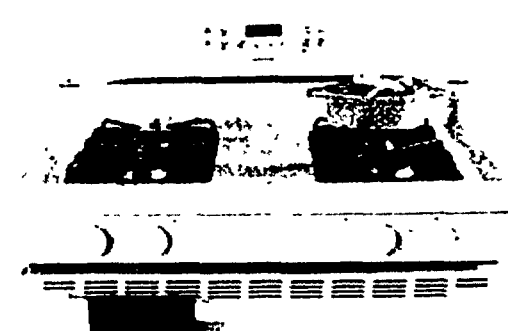

\$549 ONLY \$16 PER MONTH*
MAYTAG® ELECTRIC RANGE
Smoothtop Plus Precision Cooking™ system
Smoothtop glass-ceramic cooking surface
MERH752BAW (Depot Direct 514465)
*Stainless steel available at additional cost

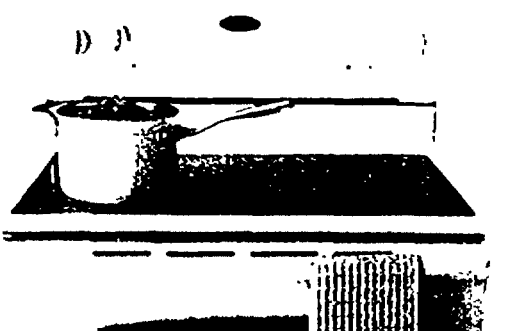

EXCLUSIVE \$139
MAGIC CHEF® OVER-THE-RANGE MICROWAVE
White, bisque or black.
MCO160UW (354546)
*Stainless Steel available at additional cost

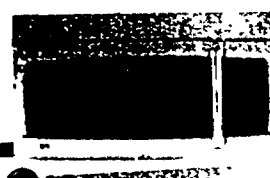

\$249 ONLY \$10 PER MONTH*
LG OVER-THE-RANGE MICROWAVE
LWVI630ST (382172, Depot Direct 321331)

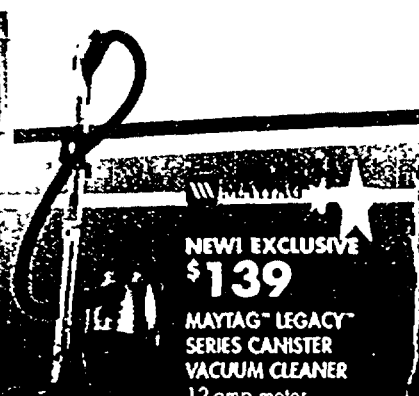

NEW! EXCLUSIVE \$139
MAYTAG® LEGACY™ SERIES CANISTER VACUUM CLEANER
12-amp motor.
(535340)



NEW! EXCLUSIVE \$149
MAYTAG® LEGACY™ SERIES UPRIGHT VACUUM CLEANER
Cyclonic filtration system.
(534827)



NEW! EXCLUSIVE \$239 ONLY \$10 PER MONTH*
MAYTAG® LEGACY™ SERIES CARPET CLEANER
Powerful scrubbing brushes (535084)

*When purchased on the Home Depot Consumer Credit Card. Additional terms apply. See page 12 for key credit terms. Offer valid by manufacturer mail-in rebate 6/28/06 - 8/23/06 with qualifying LG washer and/or dryer purchases. Offer available at all US Home Depot stores. This offer is limited to one cash rebate per household on each eligible LG appliance model. No credit if offer refused. See rebate form for details. Offer valid 06/29/06 - 07/05/06 on eligible appliance purchases, including select Floorcare, of \$297 or more (excluding taxes, warranty, delivery and installation fees) in all US, Puerto Rico, and USVI Home Depot stores. Offer not valid on 16 appliances, or prior purchases, or may not be combined with any other offer. No credit if offer refused. See associate for details. *Buy an eligible LG dishwasher between 06/07/06 and 09/06/06 and receive \$50 cash back by manufacturer mail-in rebate. Limit one rebate per customer. Accumulated rebate amount \$50.00. Offer valid while supplies last. No cash checks or substitutions allowed. See rebate form for details.

50 57 60 69 97 102 110 116 124 133 136 177 178 244 262 266 303 310 327 335 339 359 367 405 408 447 448 450 459 466 468 481 483 485 487 490 492 494 496 498 500 502 504 506 508 510 512 514 516 518 520 522 524 526 528 530 532 534 536 538 540 542 544 546 548 550 552 554 556 558 560 562 564 566 568 570 572 574 576 578 580 582 584 586 588 590 592 594 596 598 600 602 604 606 608 610 612 614 616 618 620 622 624 626 628 630 632 634 636 638 640 642 644 646 648 650 652 654 656 658 660 662 664 666 668 670 672 674 676 678 680 682 684 686 688 690 692 694 696 698 700 702 704 706 708 710 712 714 716 718 720 722 724 726 728 730 732 734 736 738 740 742 744 746 748 750 752 754 756 758 760 762 764 766 768 770 772 774 776 778 780 782 784 786 788 790 792 794 796 798 800 802 804 806 808 810 812 814 816 818 820 822 824 826 828 830 832 834 836 838 840 842 844 846 848 850 852 854 856 858 860 862 864 866 868 870 872 874 876 878 880 882 884 886 888 890 892 894 896 898 900 902 904 906 908 910 912 914 916 918 920 922 924 926 928 930 932 934 936 938 940 942 944 946 948 950 952 954 956 958 960 962 964 966 968 970 972 974 976 978 980 982 984 986 988 990 992 994 996 998 1000

ELECTRONIC CUBE AND CRUSHED ICE AND WATER DISPENSER. PuriClean® II retractable filter

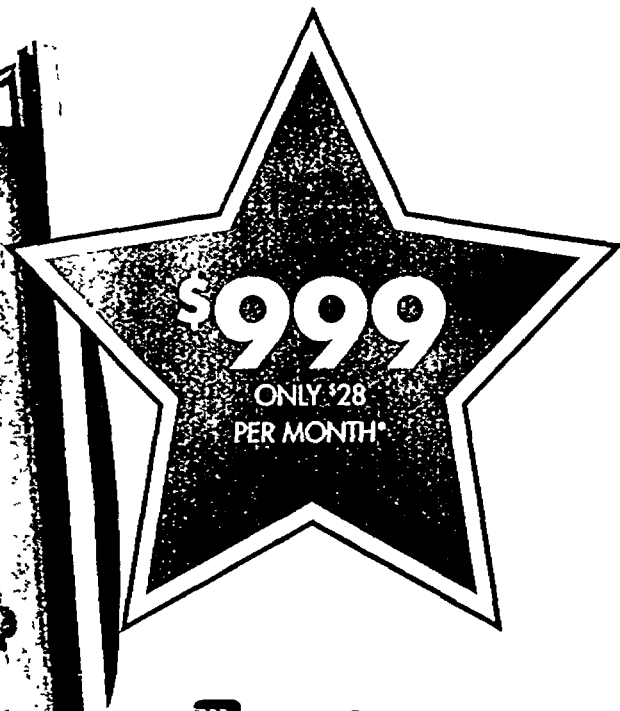

MAYTAG

MAYTAG® ULTRA STEEL 25.6 CU. FT. SIDE-BY-SIDE REFRIGERATOR

Dual Cool™ system, covered dairy compartment and adaptive defrost feature

- Deli drawer
- Spill-Catcher™ shelves
- Sealed FreshLock™ crispers
- Magnetic
- Finger print resistant

MSD2650KEU

(Depot Direct 420991)

SHOP FOR APPLIANCES ANYTIME ONLINE @ HOMEDEPOT.COM/APPLIANCES

10% OFF APPLIANCES**

OFFER VALID 06/29 - 07/05/06 ON ELIGIBLE APPLIANCE PURCHASES OF \$299 OR MORE.

12 MONTHS* NO PAYMENTS, NO INTEREST

ON ANY PURCHASE OF \$299 OR MORE ON THE HOME DEPOT CONSUMER CREDIT CARD 6/29 THROUGH 7/05/06.

FREE DELIVERY & HAUL AWAY**

ON ANY APPLIANCE PURCHASE OF \$299 OR MORE. A \$55 VALUE BY MAIL-IN REBATE.

*When purchased on The Home Depot Consumer Credit Card. Additional terms apply. See page 12 for details. **Offer valid 2/21/06 through 9/4/06 by mail-in rebate with any appliance purchase of \$299 or more (excluding taxes, warranty, delivery and installation fees) delivered through Depot Direct and EXPO Quick Ship. Normal Depot Direct and EXPO Quick Ship delivery terms apply. Delivery not available in some areas. Offer valid in U.S. (including Alaska and Hawaii) and Puerto Rico only. Not valid with any other offer. Offer only available at The Home Depot and EXPO Design Center stores. See rebate form for redemption details. Maximum mail-in rebate value is \$55. **See page 10 for details. Offer valid between 5/25/06 - 7/4/06 by mail-in rebate with the purchase of one Magic Chef Countertop Ice Maker (SKU 736328). Offer valid in U.S. and Puerto Rico The Home Depot Stores only. See rebate form for details. ***Buy on eligible LG refrigerator between 04/07/06 and 09/06/2006 and receive \$50 cash back. Limit one rebate per customer. Maximum rebate amount \$50.00. Offer valid while supplies last. No cash checks or substitutions allowed. See rebate form for details.

\$699

ONLY \$22 PER MONTH* EXCLUSIVE 25.0 CU. FT. SIDE-BY-SIDE REFRIGERATOR Dispenser, FrostGuard™ technology (Depot Direct 450246)

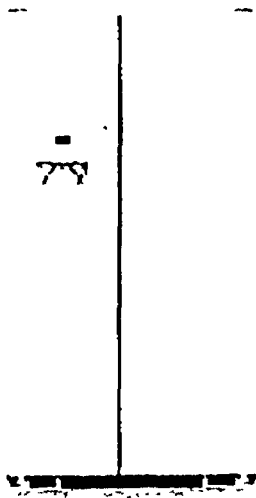

HOTPOINT \$899

ONLY \$25 PER MONTH* HOTPOINT™ 25.0 CU. FT. SILVER METALLIC SIDE-BY-SIDE REFRIGERATOR SmartWater™ filtration system Sealed deli pan HSM25GFTSA (Depot Direct 138559)

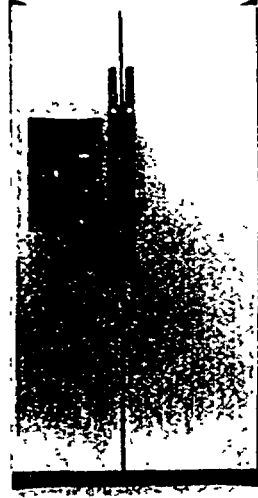

GE \$1299

ONLY \$37 PER MONTH* GE® 25.4 CU. FT. SIDE-BY-SIDE REFRIGERATOR External temperature controls Stainless steel exterior OSS25QSTSS (Depot Direct 419403)



LG \$2499

ONLY \$63 PER MONTH* LG 24.7 CU. FT. FRENCH DOOR REFRIGERATOR External ice and water dispenser Ti™ A-Drawer™ bottom freezer LFX25960ST (Depot Direct 317314)

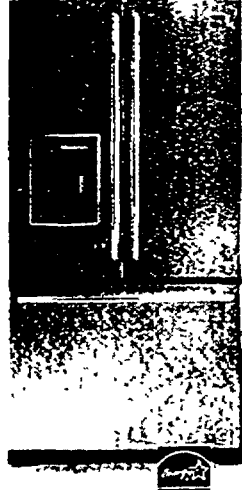

LG PLUS \$899

PLUS \$50 MAIL IN REBATE** ONLY \$25 PER MONTH* LG 22.0 CU. FT. BOTTOM FREEZER REFRIGERATOR Water Filtration system LoDecibel Operation LRBC22522WW (Depot Direct 134094)

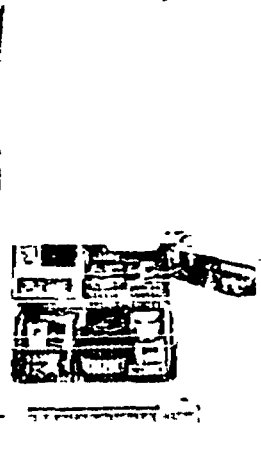

\$399

ONLY \$17 PER MONTH* 18.2 CU. FT. TOP-FREEZER REFRIGERATOR Gallon door storage NeverClean™ condenser (225334, Depot Direct 222490)



EXCLUSIVE \$149

AFTER \$30 MAIL IN REBATE* MAGIC CHEF COUNTERTOP ICE MAKER MCLM30T (736328)

EXCLUSIVE \$149

SAVE \$10 WAS \$159 MAGIC CHEF™ FREEZER 5.5 CU. FT. MCCFWBX (569925) MCCFSW (184142)

EXCLUSIVE \$99

SAVE \$20! WAS \$119 MAGIC CHEF 3.6 CU. FT. COMPACT REFRIGERATOR. MCER3-05 (627342)

EXCLUSIVE \$199

MAGIC CHEF™ 45 BOTTLE WINE COOLER MCWC45MCG (502353)

EXCLUSIVE \$299

ONLY \$13 PER MONTH MAGIC CHEF COMPACT REFRIGERATOR MCER1010W (325805)

7.2 CU. FT. \$179

SAVE \$20 WAS \$199 MCCF7WBX (539355) MCCF7W (184103)

FOR APPLIANCE PARTS CALL THE HOME DEPOT PARTS HOTLINE AT 1.800.378.5830, 11

EVERY SEASON STARTS AT

DICK'S SPORTING GOODS

Outdoor Destination Sale

Save 35% Off
49.98
Orig. 79.99
Now 69.99

LOWEST PRICE OF THE SEASON
10'x10' Instant Shelter
• Folds to 3" x 10" x 10" for convenient storage
• Instant set-up with no tools required
• Includes carry bag - a \$39.99 value
Includes carry bag - a \$39.99 value
ID# 2210790

> CHAIRS

NORTHEAST
Save 25% Off
59.99
Lazy Lounger
• Oversized pillow
• Padded arm
• Cushions
• Color selection varies by store
Orig. 79.99
✓ Double ScoreCard Points

NORTHEAST
Save 35% Off
4.98
Deluxe Logo Armchair
Reg. 7.99
✓ Double ScoreCard Points

NORTHEAST
9.99
Stars and Stripes Chair
✓ Double ScoreCard Points

Coleman
Save 20% Off
9.98
Captain's Chair
• Durable 600d polyester fabric
• Taller back height
Reg. 12.99

NORTHEAST
5.98 Reg. 7.99
Junior Armchair
✓ Double ScoreCard Points

NORTHEAST
9.99
Bright Mesh Armchair
✓ Double ScoreCard Points

NORTHEAST
14.99
Deluxe Armchair with Footrest
✓ Double ScoreCard Points

14.98 Reg. 19.99
Coleman Captain's Chair with Footrest



QUEST

Instant Shelter Accessories

10'x10' or 12'x12' First-Up Wind Curtain 29.99

10'x10' or 12'x12' First-Up Mesh Curtain 29.99

12'x12' Instant Shelter 89.99 Orig. 99.99
Online ID# 2210791

adidas

Soccer Shootout
Coming Soon to Select Stores

KICK. SCORE. WIN.

Friday, June 30 5PM to 9PM
Saturday, July 1 1PM to 5PM
Sunday, July 2 Noon to 4PM

NO PURCHASE NECESSARY. Must be legal U.S. resident to play. Subject to Official Rules posted at participating DICK'S Sporting Goods stores. 7/31/06-7/2/07. Void where prohibited.

NORTHEAST
10'x10' Garden Gazebo/Instant Shelter 199.98
Orig. 279.99
Now 249.99
• DICK'S Exclusive
• Instant set-up with no tools required
• 100 sq. ft. of shade

12'x12' Zephyr Screenhouse 49.98
Orig. 99.99
Now 59.99
• Non-see-through mesh
• Clean-lined style

Save 70% on Entire Stock of Lawn Game Sets

Bocce, croquet, volleyball and more. Excludes Highland Games Bocce Set.

15.98-144.98
Orig. 49.99-179.99

> WATERSPORTS

Pelican
499.99
Orig. 599.99
DICK'S EXCLUSIVE Rainbow Special Edition Pedal Boat
• Seats 5
• Adjustable seats move into lounging position
• Includes deluxe cooler and folding shade canopy

FREE boat storage cover by mail a \$99.99 value

ID# 2131676

129.99
12'x12' Straight-Leg Shelter
• 144 sq. ft. of shade
• Powder coated 11.2" x 2" frame
Online ID# 2276689

Entire Stock of Kneeboards and Wakeboards on Sale

O'Brien Tribal Sun Kneeboard 129.98
Orig. 199.99
Now 149.99

Hyperlite Motive Wakeboard and Vario Binding 199.98
Orig. 299.99
Now 249.99

CWB Sol Wakeboard with Torque Hinge Binding 299.98
Reg. 329.99
Online ID# 2146978
• Available in select stores

Entire Stock of Towable Tubes on Sale

79.98
Save 50% Off

Entire Stock of Ski Combos on Sale

E. O'Brien All Star Trainer 89.98 Reg. 99.99

F. H.O. Team FC Ski Water Combo 99.98 Reg. 119.99

G. O'Brien Vantage Binding Water Ski Combo 119.98 Reg. 139.99

H. Connelly Crossfire with Neoprene Front Adjust Bindings 159.98 Orig. 199.99 Now 179.99

11' Floating Water Bouncer Package 99.98
Orig. 199.99
• Includes pump and repair kit

Save up to 50% Off All Stearns Fishing Vests

Challenger 24.99 Orig. 39.99

Comfort Angler 39.99 Orig. 59.99

Trophy 39.99 Orig. 59.99

STEARNS

Save up to 50% Off Select DBX Ski Vests

4-Block Nylon Ski Vest 14.98 Orig. 29.99 Now 12.99

Hybrid Ski Vest 29.98 Reg. 39.99

GlideSkin Neoprene Vest 49.98 Reg. 59.99

Save 20% Off 19.98

Take 50% Off

• Includes carry bag - a \$39.99 value

11' Floating Water Bouncer Package 99.98
Orig. 199.99

Shop us online at DicksSportingGoods.com or order by phone at 1.877.846.9997

Save \$10

KELTY
ONLINE ITEM ID# 226306

Trekking Pole 19.99
Nalgene 32 oz. Water Bottle 7.99

89.98
Reg. 99.99

Santa Fe 4000 Internal Frame Pack
• 4000 cu. in. • Dual density shoulder and waist belts
• Sliding back panel adjusts to fit most users

Red Wing 2650 Pack
89.98
Reg. 99.99
Online ID# 2277041

Red Cloud 5600 Internal Frame Pack
179.99
Online ID# 2185811

Tour Kid Carrier
99.99
Online ID# 1915060

> CAMPING

69.99

SLEEPS 1 Solitaire Tent
• 28'x8'
• 2-hoop bivvy-style set up
• 70D nylon taffeta roof and rear vent



Eureka!

Save \$20

99.99
Orig. 119.99

SLEEPS 2 Apollo 2 Tent
• 4'10"x7'5" floor
• 3'6" center height
• Weighs 3 lb. 14 oz.

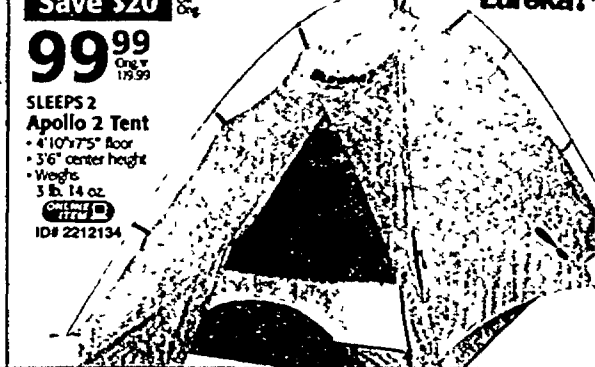

Eureka!

169.00

SLEEPS 2 Rock 22 Tent
• 33 sq. ft. floor
• Weighs 6 lb. 11 oz.
• DAC Press-Fit aluminum poles

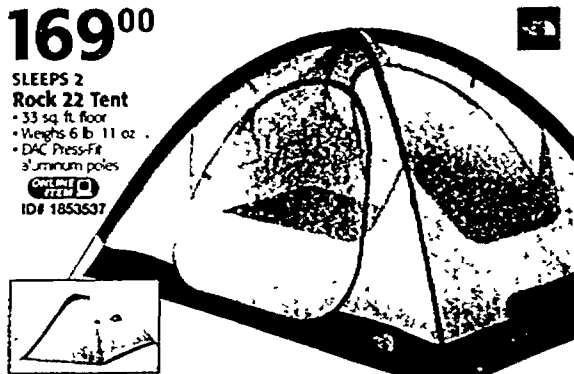

Save \$20

99.99
Orig. 119.99

SLEEPS 4 Apollo 4 Tent
• 9'x8' floor
• 5'10" center height
• Weighs 12 lb. 3 oz.



Eureka!

Save 50% **24.98**
Orig. 49.99 Now 29.99

Polaris II Mummy Bag
• Rated to 20°F
• 63" length
• 5 lb. Thermar insulation
• Draft tube and cold-proof flap



Save 25% **59.98**
Orig. 79.99 Now 59.99

One Kilo Extreme Mummy Bag
• Rated to 33°F
• Thermolite Extreme insulation
• Draft tube and cold-proof flap



79.00

Aleutian 20°F Mummy Bag
• 84" length
• 2 lb. 1 oz. of H.O.T. SL continuous, hollow-core polyester insulation



69.00

Allegheny 40°F Sleeping Bag
• 77" length
• 1 lb. 1 oz. H.O.T. SL continuous, hollow-core polyester insulation



Save \$20

79.98

Your Choice A. Jansport Scout External Frame Pack
• 3850 cu. in.
• Adjustable design
• Includes organizer pockets

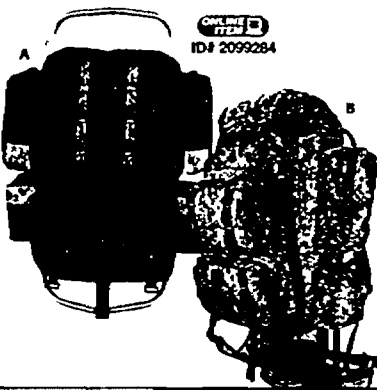

B. Mountainsmith Master External Frame Pack

Save \$10

Entire Stock of MSR Backpacking Stoves

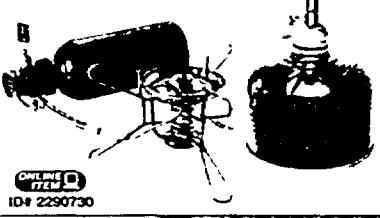

Save \$10

All MSR and Katadyn Water Filtration and Purification Systems

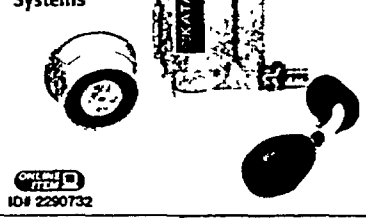

24.99

Aurora Headlamp
• Ultra-bright LED
• Multiple mode settings
• 160 hours of burn time



Quad Headlamp \$32.99

24.98

8D Rugged Twin U-Tube Lantern
• Rugged family size lantern
• Operates up to 28 hours



Rechargeable Lantern \$39.99

24.98

Queen Air Mattress
• Velour top for comfort
• Includes FREE alarm clock and pump
• Double Score™ Pockets



Save 20% **39.98**
Orig. 49.99

Queen Air Bed and Pump Combo
• 78"x50"x8.5"



Save 25% **59.98**
Orig. 79.99

Queen Double-High Air Bed with Pump
• 77"x61"x18"



Save 20% **79.99**

Classic Twin Air Mattress



> CASUAL APPAREL

14.99 to 25.00

Men's and Women's The North Face Knit Tops

• Choose from cotton graphic tees, performance ruckus crew and performance graphics
Orig. 20.00-25.00



Men's and Women's The North Face Bottoms
24.99-50.00
Online ID# 2276952

Moisture Management
UV Protection

Save 50% **2 for \$20**

Men's and Women's Quest Adventure Tees, Tanks and Shorts

• Choose from several styles
Orig. 14.99-19.99 ext.



UV Protection Quick-Dry Anti-Microbial

9.99 to 19.99

Men's and Women's Quest Apparel

• Choose from performance polos, cotton tees, tanks, cotton polos, shorts and capris
Orig. 14.99-19.99



UV Protection Quick-Dry Anti-Microbial

14.99 to 29.99

Men's and Women's Columbia Apparel

• Excludes Titanium apparel
Orig. 22.00-45.00

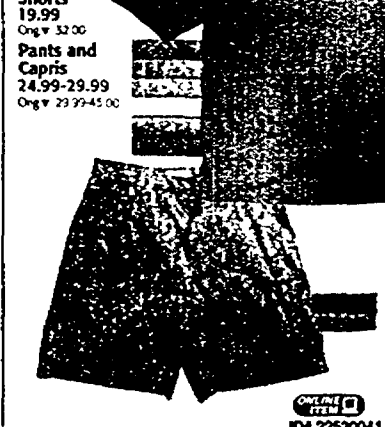

ONLINE ITEM ID# 22530041

> FOOTWEAR

29.99

Men's, Women's or Kids' Crocs Beach



• Supersoft and comfortable design
• Color selection varies by store

Save 20% **49.99**
Orig. 64.99

Men's or Women's Traverse



• 11.5" long shoe • Smooth leather with mesh upper
• Full-grain leather outsole

Save 20% **69.99**
Orig. 89.99

Men's White Ledge



• Hiking shoe • Premium, waterproof leather upper
• Dual-density EVA midsole for lightweight cushioning

74.99

Men's or Women's Mesa Ventilator



• Hiking shoe • Leather and breathable mesh upper
• Air Cushion midsole

89.99

Men's Chameleon II Stretch



• Hiking shoe • Nubuck and breathable mesh upper
• Vibram Chameleon Sport outsole

89.99

Men's or Women's Trailscape



• Hiking shoe • Gore-Tex waterproof, breathable membrane
• Ballistic mesh and leather upper

109.99

Men's Chameleon XCR



• Hiking shoe • Waterproof pebble leather upper
• Waterproof Gore-Tex XCR gasket construction

DICK'S SPORTING GOODS

Shop us online at DicksSportingGoods.com or order by phone at 1.877.846.9997

*In-store markdowns may have been taken



Get MORE Benefits, MORE Rewards.™

Apply for a Credit Rewards or Platinum Rewards Account Today!

†Subject to credit approval. Some exclusions apply. See a Store Associate for details.

> CAMPING

Save 50%
99.99
 Orig. 199.99

10x16' Tent
 • 78" center height
 • Room divider
 • 2 storage PVC windows
 • Available in select stores



Save \$20 Off
179.99
 Orig. 199.99

14x12' Vacation Home Tent
 • 92" center height
 • 2 doors and 4 windows
 • HydraTect system



Save LOWEST PRICE OF THE SEASON
50% Off
 Orig. 29.99

All Eagle's Peak Tents

- 9'x7' Eagle's Peak Tent...29.98
 • Sleeps 3
 Orig. \$59.99 Now 34.99
- 9'x9' Eagle's Peak Tent...49.98
 • Sleeps 4
 Orig. \$99.99 Now 54.99
- 10'x16' Eagle's Peak Tent...79.98 (shown)
 • Sleeps 7
 Orig. \$159.99 Now 84.99
- 11'x11' Eagle's Peak Tent...64.98
 • Sleeps 6
 Orig. \$129.99 Now 74.99

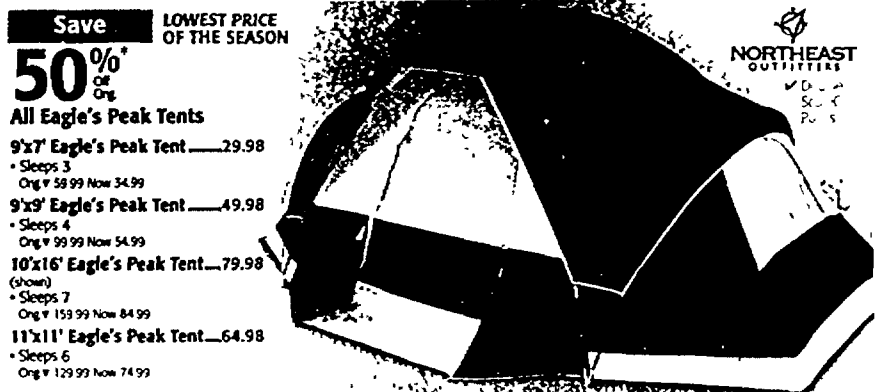

39.99

SLEEPS 3 7'x5' Sundome Tent
 • 52" center height
 • WeatherTec system for waterproof durability
 • Rainfly covers doors and windows



Save \$70 When Purchased as a Package
149.98
 Orig. \$199.99 Now 179.99

2006 Camping Package
 • 9'x7' Sundome tent
 • 2 adult sleeping bags
 • ComfortSmart double quadded
 • 12V quick pump
 • Personal twin-tube lantern
 • 1-burner propane stove



Save Up To \$20 Off
 Orig. 228.97

DICK'S EXCLUSIVE Tioga Series Tents

- 8'x8' Tioga 3 Tent...59.99 (shown)
 • Sleeps 3
 Orig. \$69.99
- 12'x12' Tioga 6 Tent...119.99
 • Sleeps 6
 Orig. \$129.99
- 14'x14' Tioga 10 Tent...159.99
 • Sleeps 10
 • Available in select stores
 Orig. \$179.99

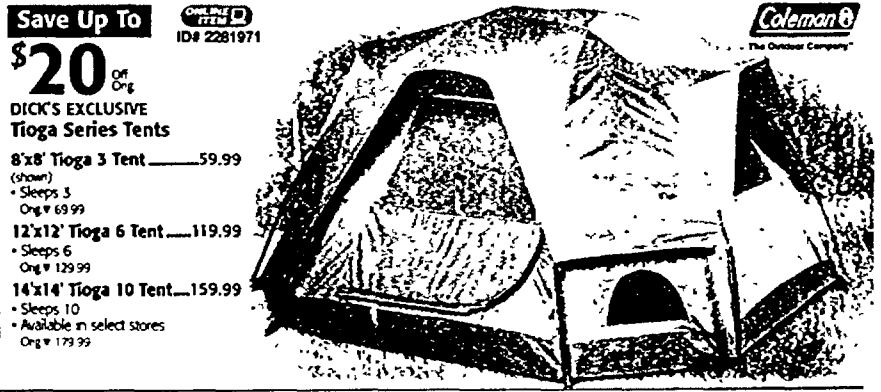

Save \$10
49.98
 Reg. 59.99

Cabin Comfort Queen Sleeping Bag
 • Queen-size double bag with box quilting
 • 7 lb. of polyester fill • Yam-dyed cotton flannel liner
 • Double ScoreCard Points

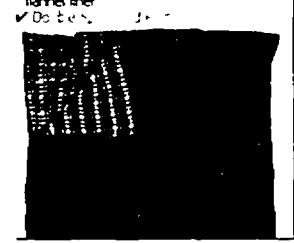

Save 25%

Laurel Ridge Sleeping Bags

- 40" 17.98 Reg. 24.99
- 20" 29.98 (shown) Reg. 39.99
- 10" 44.98 Reg. 59.99

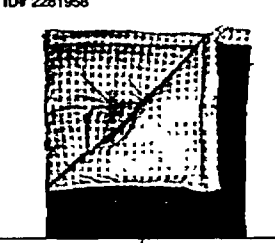

Adult Sleeping Bag 14.98 (shown) Reg. 17.99

Junior Sleeping Bag 9.99

Adult Brushed Tricot Oversized Sleeping Bag 19.98 Reg. 24.99



Save \$70 Off
69.98
 Orig. \$139.99 Now 79.99

12'x10' Redwood Tent
 • 72" center height
 • 2-room design with 2 doors

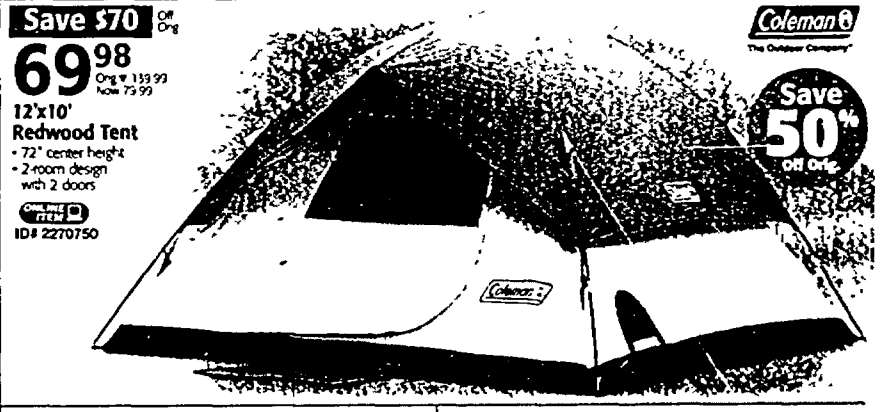

Save 20%
39.98
 Reg. 49.99

Oversized Army-Style Cot
 • 79"x31.5"x17.5"
 • Folds for easy storage
 • Includes carry case

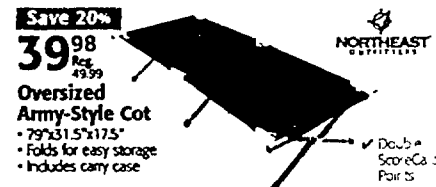

79.99

Folding Hammock
 • 100"x34"
 • Steel frame folds easily

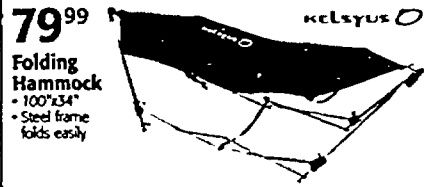

29.99

Rio Molded Camp Table
 • 24"x48"
 • 500 lb. weight capacity
 • Lightweight design
 • Sturdy molded top with tapered edges

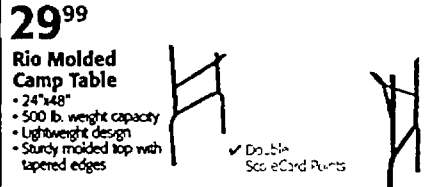

Take \$10 OFF

All Therm-A-Rest Ground Pads \$49.99 or more
 • Excludes RidgeRest ground pad



24.99

50 qt. Ice Cube Marine-Grade Cooler
 • Folding rubber grip handles and attachable cup holders

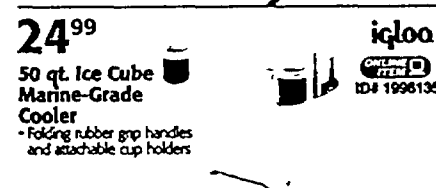

Sale 24.98
 Reg. 29.99

50 qt. Wheeled Cooler
 • Holds 64 cans plus ice
 • Hinged lid • Leak-resistant drain
36 qt. Extreme Cooler
 24.98 Reg. 29.99



59.99

100 qt. Ultra Marine-Grade Cooler
 • Convenient lid design allows access without opening the lid
 • Snap-lock child-safety latches
 • Threaded drain plug

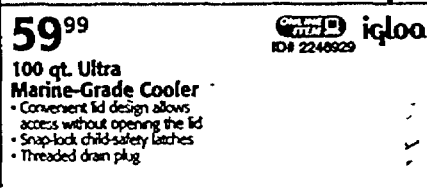

> OUTDOOR COOKING

Save 20%
19.98
 Reg. 24.99

2-Mantle Lantern with Case
 • New design takes less storage space
 Includes FREE protective case a \$9.99 value



Sale 39.98
 Reg. 44.99

HT 2-Burner Stove
 • 11,000 BTU output per burner
 • Adjustable cooking power

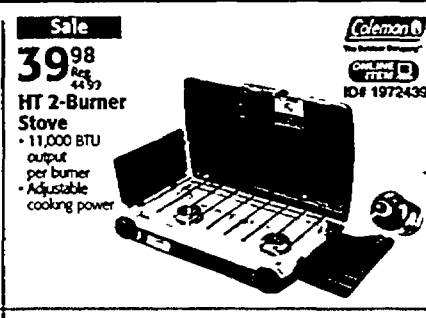

79.99

Fold n Go
 • 2 adjustable burners
 • 25% more compact than a traditional 2-burner stove
 • 20,000 BTU
 • Electronic ignition



79.99

2-Burner InstaStart Grill/Stove
 • 2 adjustable burners allow you to cook and grill at the same time
 • 20,000 BTU output
 • Easy to clean



29.99

Tabletop Propane Grill
 • Fully assembled and ready to use
 • Slide-out grease tray and oversized grill area
 • UL-approved regulator

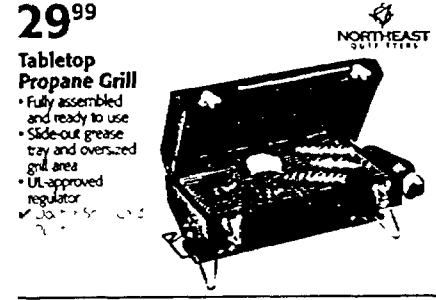

Save \$20
79.98
 Reg. 99.99

2-Burner Stove
 • 60,000 BTU output
 • Removable legs
 • Dutch oven and skillet sold separately

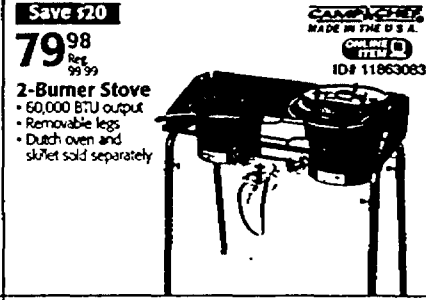

Save 25%
49.98
 Reg. 69.99

RoadTrip Slow Cooker
 • 5-quart capacity
 • Removable crock with locking plastic vented lid
 • 4000 BTU adjustable burner

16.4 oz. Propane Fuel...2.79

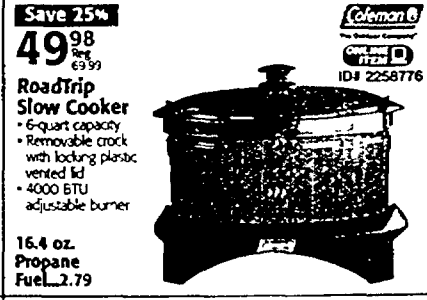

Save \$20
149.98
 Reg. 169.99

RoadTrip Grill
 • Authentic open flame, drop-through grilling
 • New grease tray slides out easily



Save 50%
29.98
 Orig. 59.99 Now 39.99

20" Outdoor Fireplace
 • 20" diameter
 • Heat resistant paint
 • Includes wheels
 • Double ScoreCard Points

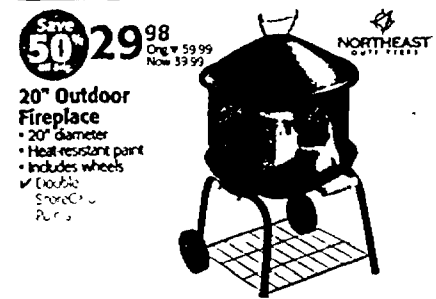

Save \$70 Off
89.98
 Orig. \$159.99 Now 99.99

Mosaic Firebowl
 • 34" diameter
 • Mosaic-patterned ceramic tiles

Includes FREE bonus cover a \$19.99 value
 • Double ScoreCard Points



Save \$10
89.98
 Reg. 99.99

Patio Fireplace with Cover
 • Wood-burning fireplace and charcoal grill
 • 24" cooking grate
 • Weather-resistant porcelain lid

DiversiTech Original Grill Pad...29.99



Stove Grate...12.99

Wheeled Carry Bag...39.99
Cast-Iron Griddle...24.99

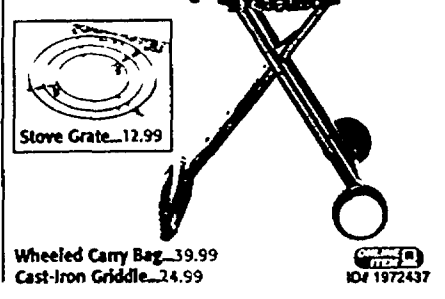

> GAMES

Save 25%
59.98
 Reg. 79.99

Regulation Bocce Set
 • 113mm resin bocce balls
 • 60mm resin pallino
 • Aluminum carrying case

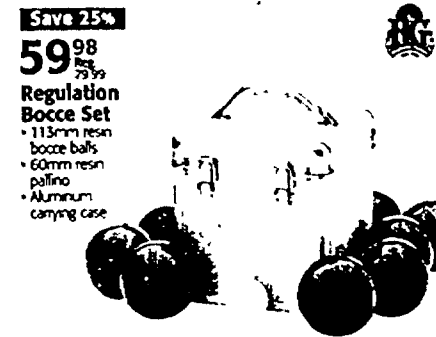

Golf Discs
 • Choose from long and mid-range drivers, putters and bags
 • Available in select stores
 Reg. 8.99-24.99

ONLINE ONLY ID# 1761565

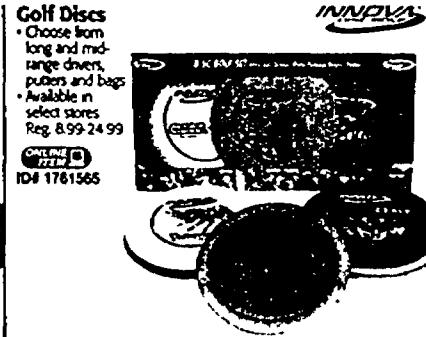

Save \$50

All Bounce Houses
 • Choose from a 16'x13' square or waterslide/bounce house combo
Sale 399.98-449.98
 Reg. 449.99-499.99



Save 50%
249.98
 Orig. 499.99 Now 249.99

Power Serve Table Tennis Table
 • Regulation 9'x5' table
 • 3/4" laminated playfield
 • 2.25" steel apron

INVENTORY CLEARANCE SALE
 Save \$50-\$250 Off on Table Games
 • Reductions already taken
 Online ID# 2290778



Save 60%
99.98
 Orig. 249.99 Now 99.99

Texas Hold 'Em Portable Poker Table
 • 84"x142"
 • 10-person, two-fold oval design
 • Durable, foldable steel legs



Save 66%
39.98
 Orig. 129.99 Now 39.99

500-Count 11.5g Chip Set
 • Includes 2 decks of cards, one (set of 5) and a sturdy aluminum carrying case



Save \$10
189.98
 Reg. 199.99

13' Trampoline
 • Rust resistant steel frame
 • Self-leveling M-shaped legs
 • UV-resistant mat

ONLINE ONLY ID# 2003664

12' or 13' Trampoline Enclosure System...119.98
 Orig. \$149.99 Now 129.99
 • Double ScoreCard Points
 Online ID# 2284906



Online Exclusive

SHIPPING SAVINGS ON SELECT SWIMWEAR

ONLINE ONLY
ID# 2279544

DicksSportingGoods.com

Offer good through 7/1/06
See website for details

> WATERSPORTS

Save \$150 Off
499.98
 DICK'S EXCLUSIVE
Montour 11.0 Drop Skeg Kayak
 • Built-in drop skeg
 • Narrower stance for speed
 • Includes footpegs and bulkhead

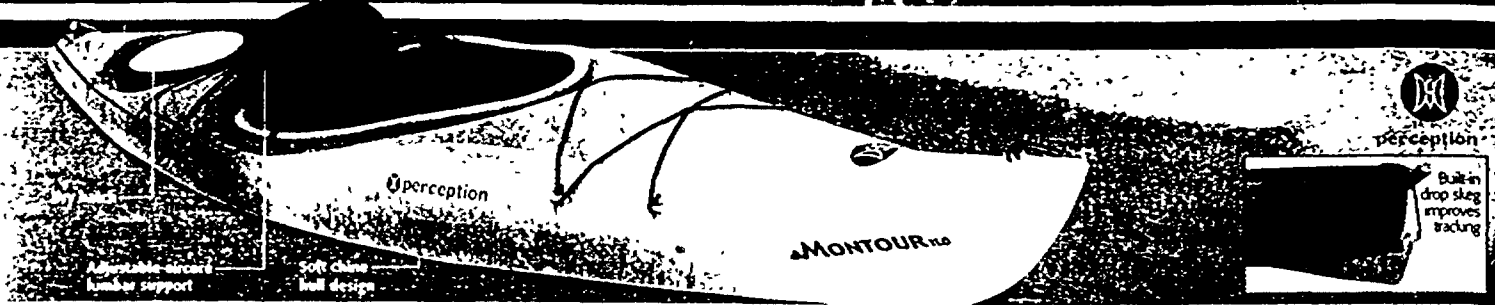

Save \$50 Off
279.98
 DICK'S EXCLUSIVE
Colorado Canoe
 • 15'6" x 37"
 • RAM-X construction
 • 3 bench seats



Save \$150 Off
349.98
 DICK'S EXCLUSIVE
Sporter Canoe
 • 13'11" x 36"
 • Weighs 89 lb
 • Fully assembled



Save \$70 Off
429.98
 DICK'S EXCLUSIVE
Guide 147 Canoe
 • 14'7" x 38"
 • Weighs 74 lb
 • Polylink construction



Save \$400 Off
599.98
 DICK'S EXCLUSIVE
Woodsmen Canoe
 • 15'2" x 35"
 • Ultra-lightweight at 56 lb
 • Wood seats



Save 20% Off
Paddling Accessories with Purchase of Any Canoe or Kayak



Save \$100 Off
229.98
 DICK'S EXCLUSIVE
Blast Kayak
 • 9'4" x 30"
 • 250 lb. capacity
 • Includes footpegs



Save \$50 Off
299.98
 DICK'S EXCLUSIVE
Otter Sport Kayak
 • 9'6" x 28"
 • Padded seat, foot pegs and deck rigging



Save \$50 Off
349.98
 DICK'S EXCLUSIVE
Frenzy Sit-on-Top Kayak
 • 9'x31" • Stable and easy to transport
 Bonus padded backrest for comfort - a \$29.99 value

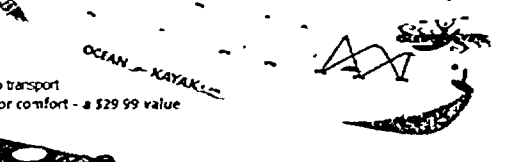

Save \$100 Off
399.98
 DICK'S EXCLUSIVE
America 11.0 Kayak
 • 11'11" x 28" • 460 lb. capacity
 • Features foot braces, hatch and oversized cockpit



Save \$20 Off
179.98

Aero XL Rooftop Cargo Box
 • ABS construction
 • Gas struts hold box open for loading and unloading
 • Long enough for golf clubs, skis and snowboards
 • 18 cu. ft. capacity

karite
 ONLINE ONLY
 ID# 2269336

Explorer Rooftop Cargo Box...129.99



Save \$20 Off
119.98

Hull-a-Port Rooftop Kayak Rack
 • Angled rack
 • Includes 2 anchoring tie-downs, 2 buckle straps and all hardware to fit factory and aftermarket roofracks

TRULE

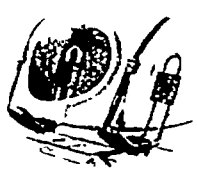

ONLINE ONLY
 ID# 1982019

Save 50% Off
24.98

NEW FOR 2006 Strap-On Wheel Step
 • No-slip step attaches to vehicles wheel
 • Provides extra height for loading gear onto roof
 • Includes storage bag
 • Double ScoreCard Points

NORTHEAST



Save 50% Off Orig.
89.98

Weatherproof Cartop Cargo Carrier
 • Waterproof fabric construction with 100% sealed seams
 • Waterproof zippers and velcro closure on weatherproof flap
 • 15 cu. ft. capacity

NORTHEAST

Car-Pak Cargo Carrier...39.98

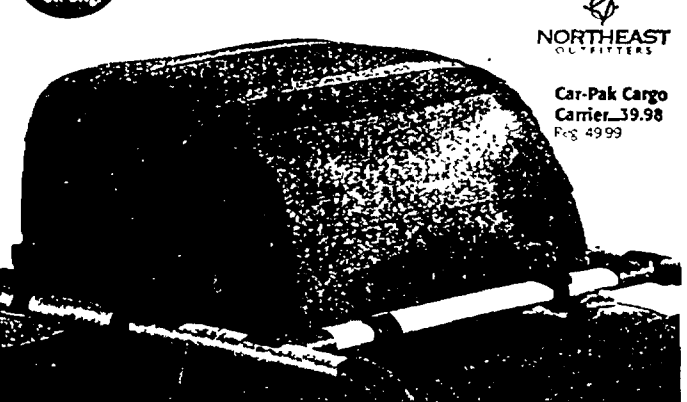

> SANDALS

29.99

Men's, Women's or Kids' Crocs Athens
 • Super soft and comfortable design
 • Kids' available in select sizes
 • Color selection varies by store



DICK'S EXCLUSIVE Save \$5 on All Men's and Women's Rafter's Sandals
 • Choose from several styles
 Sale 19.99-24.99 Orig. 24.99-29.99



Men's or Women's Teva Sandals
 • Sturdy cross-strap thong upper
 • Superior multi-coated outsole
 • Soft, Duraportex EVA midsole

> SWIMWEAR

Save 25% to 60% Off

Women's, Men's and Kids' Swimwear
 • Choose from Speedo, Nike, Atria, D&G, Ocean Core and more
 • Selection varies by store
 Sale 7.98-53.98
 Orig. 14.99-72.00
 Now 9.99-72.00
 ONLINE ONLY
 ID# 2253127



Save 20% on Entire Stock of Snorkeling Gear

> TECHNOLOGY • OPTICS

Save \$10 Off
99.98
10x50 Action Binoculars
 • Quick, smooth central focusing
 • Bak4 prisms
 • Multi-coated

Nikon



Save 50% Off
79.98
10x42 Scout Binoculars
 • Waterproof and shockproof
 • Superior multi-coated optics
 • Wide field of view

Bushnell



Save 33% Off
49.99 Now -10.00 Mail-In Rebate
39.99 Final Cost
T5000GR Radio 2-Pack
 • 8-mile range
 • 22 channels
 • 15S, 15PS radios
 • 15 digital privacy codes
 • Quiet talk noise filter

MOTOROLA

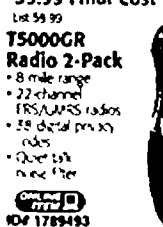

Save \$100 Off
349.99
NEW FOR 2006 eTrex Legend CX Bundle
 • SD card expandability
 • Includes US topographical software, car adapter, instructional DVD and carry case
 If purchased separately a \$450 value

GARMIN

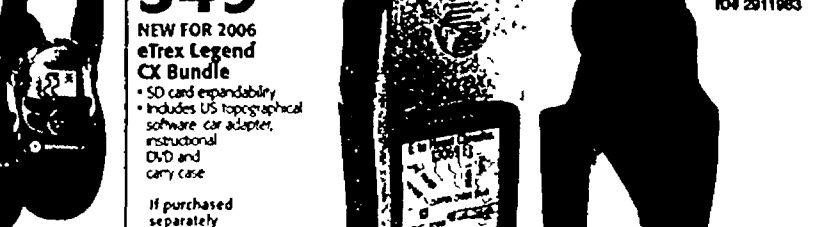

Save \$10 Off
149.98
Yardage Pro Sport 450 Rangefinder
 • Laser rangefinder
 • 4-power magnification
 • 400-yard range

Bushnell



199.99
ProStaff Laser 440 Rangefinder
 • Multi-coated BK optics
 • 440-yard range with 1/2 yard accuracy
 • Water resistant

Nikon



249.99
NEW FOR 2006 Forerunner 205 GPS Personal Training Device
 • New high sensitivity GPS receiver
 • Provides accurate speed, distance and calories burned
 • Includes training center CD, docking cradle and USB cable

GARMIN

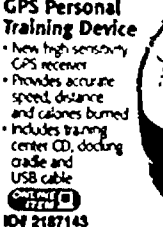

eTrex GPS Unit...99.99
 Orig. 119.99
 Online ID# 84675

DICK'S SPORTING GOODS

Shop us online at DicksSportingGoods.com or order by phone at 1.877.846.9997

*Internet markdowns may have been taken

Take an Additional 25% Off any Clearance-Price Fishing Rod, Reel, Combo or Wader.

> FISHING

Save \$50 Off
49.98
Orig. \$99.99
Now \$49.99

Your Choice
DICK'S EXCLUSIVE
A. Inferno Spinning Reel

- 10 stainless-steel ball bearings
- Computer-balanced rotor
- FREE spare aluminum spool

DICK'S EXCLUSIVE
B. Inferno Baitcast Reel

- 5 stainless-steel ball bearings
- Dynamic magnetic cast control
- Continuous anti-reverse

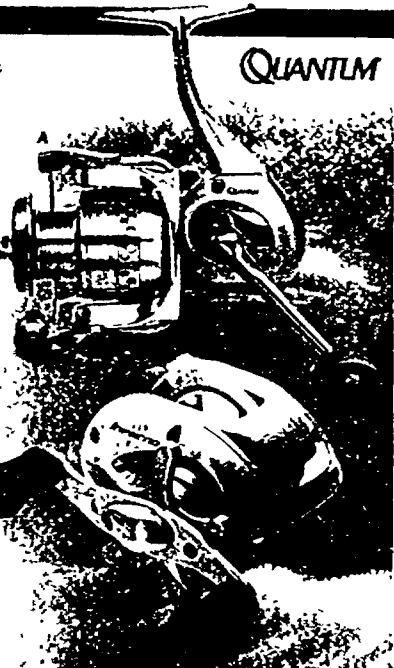

Save \$10 Off
219.98
Orig. \$229.99

Endura 55 Trolling Motor

- 55 lb thrust • 12V
- Transom mount
- 100% weedless propeller
- Super-strong composite shaft

Online ID# 2004467

Endura 30 Trolling Motor
\$4.98 Reg. \$9.99

Endura 36 Trolling Motor
\$139.98 Reg. \$149.99

MINN KOTA



Receive a **FREE** Bottom Line Tournament 1101 Fish Finder by mail a \$59.99 value When You Buy One Endura 55 Trolling Motor

Berkley

A. Trilene XL or XT Fishing Line

- 4, 6 or 8 lb tests
- Heavier lb. tests slightly more

5.00
Reg. \$4.99



B. Vanish Fishing Line

- 250-yard spool
- 2, 4, 6 or 8 lb tests
- Larger sizes slightly more

7.98
Reg. \$9.99



C. Fireline Fishing Line

- 125-yard spool
- Choose from 4, 6, 8, 10, 14, 20 or 30 lb tests

11.98
Reg. \$15.99

Spend \$10 on any of these lines and receive a \$5 mail-in rebate. Limit 5 rebates per household.

Save 50% Off
29.98
Orig. \$59.99
Now \$29.99

DICK'S EXCLUSIVE
Stratus GT Spinning Reel

- 9 ball bearings
- Machined aluminum spool
- Instant anti-reverse



Starting at
27.99

Ugly Stik Rods

- Choose from assorted actions and sizes
- Selection varies by store

Online ID# 2277063

Save \$10 Off
79.98
Orig. \$89.99
Now \$79.99

NEW FOR 2006
Cuda 242 Fish Locator

- High-contrast 240x160 pixel display
- 4" diagonal screen
- 800W peak-to-peak power

Online ID# 2188000

Cuda 242 Portable Fish Locator...109.98 Reg. \$119.99

5.99

10-Pack Senko Worms

- Choose from sizes 4" and 5"
- Available in a variety of colors
- Fretpop and Laminated colors slightly more

Buy Four Get One FREE

Yum Soft Plastics

- Choose from dingers, buzz frogs, wooly bugs and more
- Reg. 2.43-3.99 each

Save 20% Off
39.99
Orig. \$49.99
Now \$39.99

DICK'S EXCLUSIVE
Gold Medalist Pro Spinning Reel

- 8 ball bearings
- Machined aluminum handle
- FREE spare aluminum spool



Save 25% Off
59.99
Orig. \$79.99
Now \$59.99

10.00 Mail-in Rebate
49.99 Final Cost
List \$69.99

Cardinal 500 Lightning Rod Spinning Combo

- 8 ball bearings
- Instant anti-reverse

Save \$30 Off
139.98
Orig. \$169.99
Now \$139.98

Fishmark 320

- 320x320 pixel display
- 800 depth capability
- 60 degrees of detection coverage

Online ID# 2200073

Fish Easy 320C Fishfinder
\$189.98 Orig. \$219.99 Now \$199.99

20% Off
All Zoom Baits

- Choose from a variety of colors and styles
- Sale 1.68-3.18
- Reg. 2.13-3.99

Buy Four Get One FREE

Booyah Jigs, Spinnerbaits and Buzzbaits

- Choose from Booyah blade baits and jigs, Pond Magic, Boo Jigs and more
- Reg. 1.69-4.99 each

Save 50% Off
69.99
Orig. \$139.99
Now \$69.99

DICK'S EXCLUSIVE
Capricorn Baitcast Reel

- 9 bearing system
- Free-floating spool
- Infinite anti-reverse



Save 50% Off
24.98
Orig. \$49.99
Now \$24.98

Family Spincast Combo Pack

- 2 complete spincast combos
- Prespooled with line

Online ID# 2200073

Save 50% Off
24.98
Orig. \$49.99
Now \$24.98

Magnum Pro Series Tackle Bag

- Includes 4 3600 Series ProTack utility boxes
- 3 zippered pockets
- Molded bottom

Save 50% After Purchase on 3 Package Purchase
3 for 12.00 Sale Price
- 5.00 Mail-in Rebate
3 for 7.00 Final Cost Reg. 4.99 each

Gulp Soft Baits

- Freshwater rod package gulp only
- Out fishes live bait

Save 35% Off
19.99
Orig. \$29.99
Now \$19.99

Islamorada Collection Fishing Shirt or Pants

- Choose from vented long-sleeve shirts and zip-off nylon pants
- Durable ScoreCard Points

> HUNTING

ROSSI

Youth Matched Pair

- 22LR/410 ga. • 22LR/20 ga.
- Interchangeable barrels

99.98
Orig. \$189.99
Now \$99.99

Savage

MKII BXP or 64BXP (shown)

- Semi-auto 22LR or bolt-action 22LR

149.98
Orig. \$199.99
Now \$149.99

ROGER

10/22 Semi-Auto

- 22 calibre
- 10-shot 22LR rotary magazine
- Hardwood stock

169.98
Reg. \$179.99

Savage

93RGVXP

- 17 calibre
- Includes variable scope

219.98
Orig. \$269.99
Now \$219.99

ROSSI

Triple Threat

- 20 ga. 243 and 22LR
- 3-barrel combo

229.98
Reg. 269.99

ROSSI

Varmint Combo

- 223 calibre
- Heavy barrel, break action rifle

249.98
Orig. \$349.99
Now \$249.99

Stoeger

Condor O/U

- 12 or 20 ga. • 3" chamber
- 2 chokes • Ventilated recoil pad

299.99
Orig. \$399.99

SPARTAN

Spartan O/U

- 12 or 20 ga. • 3" chamber
- Nickel receiver with bird scene engraving

449.98
Orig. \$599.99
Now \$449.99

Stoeger

Condor Matched Set

- 2-barrel set • 3" chamber
- Includes 12 ga. and 20 ga. barrels

449.98
Orig. \$599.99
Now \$449.99

Imported by Borealis

Diamond O/U

- 12/28 or 20/26
- Silver receiver with European scroll design
- Deluxe walnut stock

799.98
Orig. \$1099.99
Now \$799.99



REMINGTON-WINCHESTER	PRE CASE PRICE*	SALE	REG.
All Purpose Shot Shells • 12 or 20 ga. • Box of 20	2.98	3.18	3.49
Gun Club Shot Shells • 12 or 20 ga. • Box of 25	3.98	4.68	4.99
AA or STS Target Loads • 12 or 20 ga. • Box of 25	4.98	5.28	5.49
UMC 9mm • Box of 50	5.98	6.98	7.99
UMC .380 Auto or .38 Special • Box of 50	9.48	9.98	10.99
UMC .45 ACP or .40 S&W • Box of 50	9.98	10.98	12.99

*\$1 Case Price is price per box when you buy 10 boxes or more

Save 25% Off
29.98
Orig. \$39.99
Now \$29.99

Ultramax Bulk Pack

- Choose from 223 150-pack, 45 150-pack, 40 275 pack, 38 200-pack and 9 mm 250-pack

Remington

17.98
Orig. \$19.99
Now \$17.99

Target Loads

- 12 or 20 ga.
- Box of 100

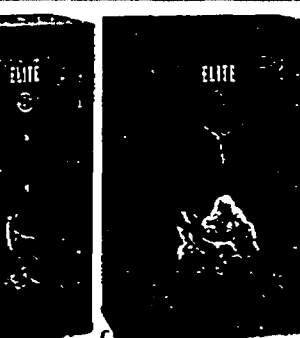
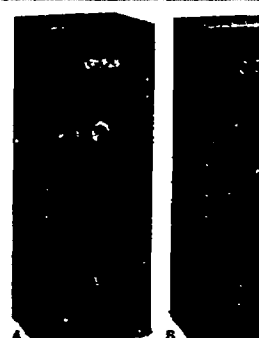
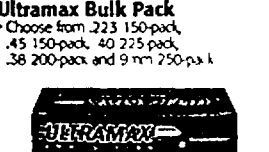

Save \$100 Off
499.98
Orig. \$599.99
Now \$499.98

A. 20-Gun Fire Safe

- Fire protection to 1400°F
- Convertible interior
- Combination lock
- 5 active bolts
- Online ID# 2258211

Save \$100 Off
799.98
Orig. \$899.99
Now \$799.98

ELECTRONIC LOCK B. 36-Gun Fire Safe

- Convertible interior
- 5 active bolts
- Solid-steel
- Online ID# 1841245

Save \$100 Off
999.98
Orig. \$1099.99
Now \$999.98

ELECTRONIC LOCK C. 45-Gun Fire Safe

- Fire protection to 1400°F
- Convertible interior
- Online ID# 2253407

Save \$20 Off
79.98
Orig. \$99.99
Now \$79.98

10-Gun Cabinet

- For rifles or shotguns
- Foam-padded bottom
- 3-point locking system

Save \$130 Off
299.98
Orig. \$429.99
Now \$269.99

16-Gun Safe

- Solid steel
- 5 large locking bolts
- Online ID# 2258213

Save \$120 Off
299.98
Orig. \$419.99
Now \$299.98

MagCat Bow Package

- One cam
- 35" let-off
- 3 1/2" axle-to-axle
- 3 lb. 9 oz.
- RH 28"-30" 50-60 lb and 60-70 lb
- Includes TRUCIO 3 pin sight, prong rest, quiver and strong accessory kit

If purchased separately a \$419.99 value

Save \$40 Off
59.98
Orig. \$99.99
Now \$59.98

15' Hunter Ladder Stand

- Three 5' ladder sections
- 300 lb. capacity

Includes **FREE** full-body fall-resistant system a \$19.99 value

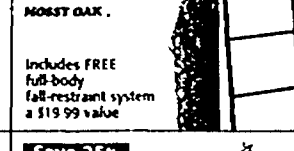
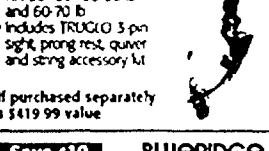

Save 40% Off
39.98
Orig. \$69.99
Now \$39.98

Stinger R34 Soft-Air R. Te

- Hop-Up system • Holds 20 plastic BBs in the magazine and 400 in the reservoir
- Includes LED flashlight and red cross-hair

5000-Count Soft-Air BBs...9.99
Online ID# 2290784

Save 25% Off
49.98
Orig. \$69.99
Now \$49.98

Pulse R70 Soft-Air Rifle

- Fully automatic
- Rechargeable • Holds 20 plastic BBs in the magazine and 400 in the reservoir
- Online ID# 2055200

10,000-Count Soft-Air BBs...19.99
Online ID# 2290785

Save \$100 Off
169.98 Sale Price
- 20.00 Mail-in Rebate
149.98 Final Cost
Orig. \$249.99
Now \$199.99

Digital Cam Combo Pack

- 1.3 megapixel monochrome digital camera
- Takes 1.3 images per triggering or 10-second video clips
- Lock bracket, combination lock, card reader and batteries

Save 50% Off
59.98 Sale Price
- 10.00 Mail-in Rebate
49.98 Final Cost
Orig. \$99.99
Now \$59.99

Digital Scouting Camera

- 0.3 megapixel
- Captures single-frame images
- 8 MB SD-RAM internal memory
- 512 MB of memory

Save \$10 Off
59.98
Orig. \$69.99
Now \$59.98

6-Point Buck 3D Archery Target

- Durable foam construction

Save 25% Off
29.98
Orig. \$39.99
Now \$29.98

Layered Archery Target

- 20" x 16" x 11"
- Use with broadheads or field tips



Key Contact Info

TO FIND A STORE NEAR YOU:
1.866.819.0038
DicksSportingGoods.com

CUSTOMER SERVICE:
1.866.677.4771
CustomerService@dcs.com

SHOP BY PHONE OR ONLINE:
1.877.846.9997
DicksSportingGoods.com



UNDER ARMOUR

Men's, Women's and Kids' Under Armour Apparel

- Available in a variety of colors and styles
- Reg. 19.99-69.99

heatgear™

Perfect for any activity on the field or on the job, Heat Gear's Moisture Transport System wicks away moisture to keep you dry and helps regulate body temperature in extremely warm weather.

ONLINE ID# 2138915

NIKE DRI-FIT

NIKE PRO

Men's and Kids' Pro Revolution and Pro Compression Apparel

- Kids available in select stores
- Reg. 15.00-35.00

Nike Pro Revolution

Moisture-wicking performance-enhancing apparel to fit your unique style or match your team's colors.

ONLINE ID# 2276968

fitness gear

Save 25%*

Men's Fitness Gear Running Apparel

- Choose from pants, shorts, short-sleeve and long-sleeve tops
- Sale 14.98-24.98
- Orig. 19.99-34.99
- *Double Score Card Points

19.99

Men's, Women's or Kids' Loose Gear Technical Tee

- Available in a variety of colors

ONLINE ID# 2276894

39.99

Men's Metal Short-Sleeve Tee

- Fabric maximizes moisture transport
- Selection varies by store

ONLINE ID# 1840387

Men's Pro Compression Performance Apparel

- Vented mesh design keeps you cool and dry
- Reg. 20.00-35.00

ONLINE ID# 2227405

Men's Dri-FIT and Sphere Apparel

- Choose from several styles of shirts, shorts, pants and more
- Moisture-wicking construction keeps you dry
- Reg. 20.00-55.00

ONLINE ID# 2277026

Save 33%

2 for \$20

Men's Fitness Gear and Women's Ativa Performance Tees

- Choose from short-sleeve and sleeveless tees
- Reg. 14.99 each

24.99

Men's Heat Gear Compression Shorts

- Compression design offers protection with comfort
- Form-fitting fabric

ONLINE ID# 525455

18.99

Men's Under Armour Boxer Briefs

- 100% microfiber with 4-way stretch design
- Moisture-wicking fabric

ONLINE ID# 1069544

Men's Pro Training Technical Tees

- Choose from long-sleeve, short-sleeve and sleeveless tops
- Reg. 22.00-30.00

ONLINE ID# 2289786

Men's Nike Dri-FIT Running Shorts

- Choose from a variety of colors and styles
- Reg. 30.00-35.00

Save 25%*

Women's Ativa Running, Fitness and Yoga Apparel

- Choose from several colors and styles
- Double Score Card Points
- Sale 9.98-26.78
- Reg. 14.99-35.99

> CLEATS/SLIDES

109.99

Adult Metal Mid D

- Detachable metal topped cleats
- Maximum support and lightweight stability for bigger players

99.99

Adult Metal Speed Mid

ONLINE ID# 2253015

> TRAINING/RUNNING SHOES

84.99

Men's Free™ Trainer 7.0

- Training shoe
- Breathable and lightweight
- Supportive forefoot strap allows lockdown
- Selection varies by store
- Also available in black/silver

DICK'S EXCLUSIVE COLOR

99.99

Men's or Women's Shox Turb Oh

- Running shoe
- Breached heel column creates softer crash zone at initial impact
- Deepened flex grooves adds flexibility to forefoot for smoother toe-off
- Kids' Shox Turb Oh...84.99

ONLINE ID# 2253222

Save 20%

19.98

adissage or Santionuevo

- Sport slide
- Polurethane footbed

ONLINE ID# 2253015

Save 35% Off

39.98

Men's Gel Advantage

- Running shoe
- GEL cushioning in heel
- Midfoot support

DICK'S EXCLUSIVE

Save \$10

49.98

Your Choice

- Men's 621
- OR Men's Air Monarch III
- Training shoe
- Online ID# 2262814

Save 25% Off

49.99

Men's Superstar 2G

- Lifestyle shoe
- Full-grain leather upper
- Shell toe
- Also available in white/navy
- White/silver available in select stores

Save \$10

64.98

Women's or Men's Gel 1110

- Running shoe
- GEL cushioning
- Men's wide widths available in select stores

ONLINE ID# 2253023

> FOOTBALL

Save \$5 on All Youth Bike Shoulder Pads

39.98-49.98

Reg. 44.99-54.99

Online ID# 2290787

Adult or Youth Practice Jersey 9.99 Orig. 14.99

Youth Nike Speedrack IV Receiver Gloves 14.98 Reg. 20.00

Adult or Youth Practice Football Pants 14.99 Orig. 19.99

Youth Under Armour Heat Gear 6-Pocket Girdle 24.99 Online ID# 1738746

Nike 1205 Football 20.00

Youth Bike 7-Piece Pad Set 9.98 Reg. 14.99 Online ID# 1953045

> SOCCER

Save 20%* when purchased as a Package

39.99

If purchased separately a \$51.50 value

adidas Soccer Package

- Includes World Cup gleder ball in sizes 3, 4, or 5, and Club Pro shinguards

ONLINE ID# 2201183

> BASEBALL

EASTON

399.99

-3 OZ. Stealth Comp Baseball Bat

- 100% composite barrel and handle
- Extended barrel for maximum hitting area
- BESR certified

-9 OZ. Stealth Comp Senior League Bat 299.99 Online ID# 2253292

ALL-COMPOSITE DESIGN

Stronger materials offer a bigger sweet spot and improved performance along the entire barrel

CONNECTION™ TECHNOLOGY

Provides more efficient energy transfer for a quicker bat and more power

CARBON NANOTUBE COMPOSITE HANDLE

Delivers optimized flex, responsiveness and lock

ONLINE ID# 2252102

39.99

Adult Enzo Receiver Gloves

- Heat Gear side panels wick away moisture
- Taped palm for ventilation and superior ball control

Nike Adult Magnigrip Threat Receiver Gloves 40.00

ONLINE ID# 1952927

Chin Shield 6.00

Under Armour Chinstrap (shown) 19.99

2-Pack Chin Pads 14.99

Online ID# 2289390

Save 20% Off

39.99

2-Pack Instant Goal Set

- Sets up in minutes and stores easily
- Save \$10 on all Soccer Goals and Rebounders
- Excludes Power Ball 2-Pack Instant Goal Set
- Sale 39.98-119.98 Reg. 49.99-129.99

24.99

Contain Shinguards

- Available in Youth or Adult
- Black or red

ONLINE ID# 2170874

Save

\$10

All Regular-Price Ball Gloves \$49.99 or more

Sale 39.98-239.98 Reg. 49.99-249.99

Save

\$10

All Regular-Price Bats \$99.99 or more

- Excludes Easton Stealth Comp, Louisville Slugger Fast End and DeMarini Vexx on 07
- Sale 89.98-289.98 Reg. 99.99-299.99

79.99

Adult Intensity Mid

- Detachable cleats
- Versatile, lightweight design
- Also available in white

ONLINE ID# 2281838

89.99

Adult Super Speed D 3/4

- Detachable cleats
- Lightweight, synthetic upper
- Available in team colors

Save \$10 Off

79.99

Adult Predator Absolion FG

- Molded soccer cleats
- Full-grain leather upper
- Available in select stores

ONLINE ID# 2280640

Save \$20 Off

99.99

Adult Brasil Elite RTX 12

- Molded soccer cleats
- Lightweight, water-resistant leather upper
- Available in select stores

Save

29.99

Adult Keystone

- Molded baseball cleats
- Lightweight, durable synthetic upper
- Newly designed, sculpted Phylon midsole

ONLINE ID# 2269798

Save \$10 Off

34.99

Adult Franchise Mid Molded

- Molded baseball cleats
- Wave Technology

ONLINE ID# 1999980

STORE HOURS: Mon. thru Sat. 9am to 9:30pm Sun. 10am to 7pm

SALE EFFECTIVE JUN 25 26 27 28 29 30 1

BALTIMORE, BANGOR, THACA & WASHINGTON D.C. SALES OFFICE

ONLINE ID# 2253015

EVERY SEASON STARTS AT
DICK'S
SPORTING GOODS

TENT SALE CLEARANCE EVENT

Hurry In for Best Selection

Thousands of Clearance Items from the Best Brands

MEN'S, WOMEN'S AND KIDS' CLEARANCE APPAREL

Choose from several styles of athletic, casual and golf apparel including shorts, polo's and more

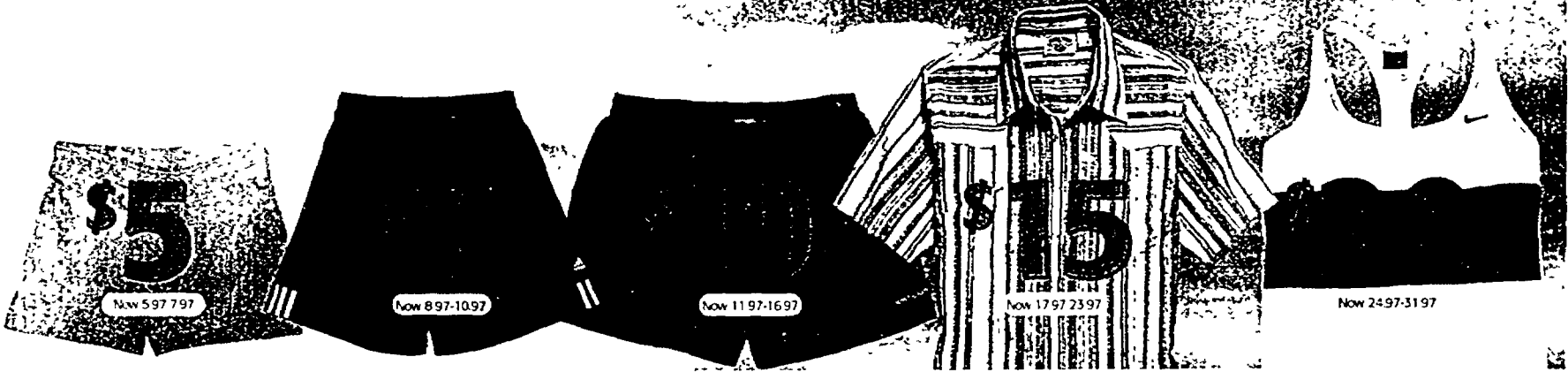

MEN'S, WOMEN'S AND KIDS' CLEARANCE FOOTWEAR Online ID# 970470



> GOLF CLEARANCE

<p>Save Up To 60% All Clearance Loose Woods, Loose Irons and Complete Wood and Iron Sets Starting at \$19.97</p> 	<p>Save Up To 60% All Clearance Golf Bags Starting at \$29.99</p> 	<p>Save Up To 50% All Clearance Golf Gloves and Accessories Starting at \$1.97</p> 	<p>Save Up To 70% All Clearance Golf Balls Starting at \$7.99</p> 
---	--	--	--

> GREAT VALUES IN EVERY DEPARTMENT

<p>Save 20% Select Men's, Women's and Kids' Nike and adidas Shorts, Tees, and Capris * Excludes Nike Dri-FIT, Sphere, Pro Compression, Pro Revolution and adidas WCO6 apparel Sale 9.58-27.98 Reg. 12.00-35.00</p> 	<p>Take an Extra 15% OFF All Clearance Bikes</p> 
---	---

<p>Save 55% 3 for \$20 Women's Ativa Rib Tanks * Choose from a variety of solid colors and tie dyes Reg. 12.99-14.99 each ✓ Double Strapped Women's Ativa and Sofie Cheer Shorts 3 for \$20 Reg. 19.99 each Online ID# 97960</p> 	<p>Save 35% 12.98 Reg. 20.00 Mens' Porto Shorts * Choose from a variety of colors Kids... 9.98 Reg. 18.00</p> 	<p>Save \$50 When Purchased in a Package 99.98 Reg. 179.99 If purchased separately a \$150 value Sonix Pro Paintball Kit * Semi-Auto Sonix marker with bottom line and gas through foregrip * 12 oz CO2 tank * Java X type goggles</p> 	<p>Save \$120 When Purchased in a Package 159.98 Reg. 189.99 If purchased separately a \$280 value Spyder Sniper Paintball Kit * Semi-Auto Sniper marker with bottom line and gas through foregrip * Includes FREE replacement barrel</p> 
<p>Save \$150 After Rebate When Purchased in a Package 209.98 Sale Price -30.00 DICK'S Mail-In Rebate 179.98 Final Cost Reg. 279.99 eTrex Legend GPS Bundle * 12 parallel channels * 500 waypoints * Includes US topographical software ID# 1997426</p> 	<p>Save Up To 50% All Clearance 2-Way Radios Starting at \$19.97</p> 	<p>1000-Count Paintballs... 17.98 (Show) Orig. 24.99 Now 19.99 1500-Count Paintballs... 29.98 Includes heavy-duty, reusable paintball case - a \$5.99 value Reg. 34.99 2000-Count Whack Paintballs... 34.98 Orig. 44.99 Now 39.99 Online ID# 2290793</p> 	<p>Save \$50 or 10% 149.98 Reg. 199.99 Now 159.99 Pilot ACS Paintball Marker * Electronic trigger frame with LED readout * New anti-chop system * Fires up to 20 paintballs per second ID# 2290786</p> 

Shop us online at DicksSportingGoods.com or order by phone at 1.877.846.9997

DICK'S

SPORTING GOODS

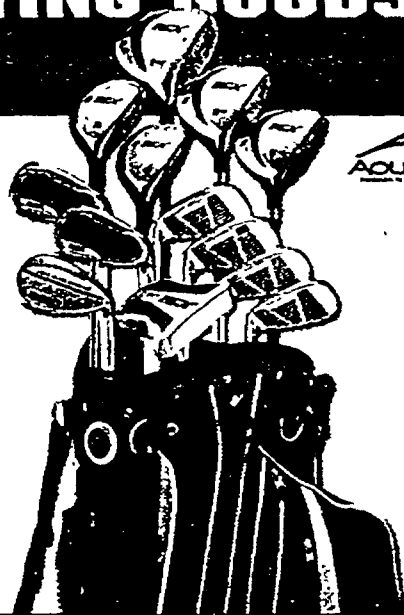

SAVE \$100
OFF ORIG.

- ✓ Double ScoreCard Points
- 19-PIECE SET RCX Combo**
- 460cc titanium driver,
- 2 fairway woods,
- 2 hybrids, 6 irons,
- wedge and putter
- Deluxe stand bag
- Men's and Women's right- and left-handed
- Orig. \$299.99

\$199.99

THE DRIVE OF A WINNER

SAVE \$350
OFF ORIG.

- Your Choice**
- A. ERC Fusion Driver**
- Men's right-handed
 - Limited to stock on hand
 - No ransheds
 - Orig. \$499.99
- B. R580XD Driver**
- Men's right- and left-handed
 - Women's right-handed • Limited to stock on hand • No ransheds
 - Orig. \$399.99

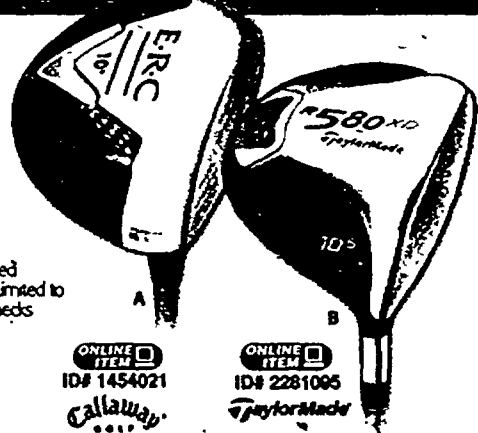

ONLINE ITEM
ID# 1454021
Callaway

ONLINE ITEM
ID# 2281005
TaylorMade

\$149.99

THE SWING OF A WINNER

SAVE 50%
OFF ORIG.

- GT Xtreme 2 Irons**
- 10-piece set • 5-PW irons
 - High-lofted 3 and 4 irons
 - Includes sand wedge and lob wedge
 - Men's right- and left-handed
 - Women's right-handed
 - Orig. \$399.99

\$199.99

SAVE \$200
OFF ORIG.

- DICK'S EXCLUSIVE r5 XL Irons**
- 3-PW • Steel shaft
 - Men's right- and left-handed
 - Women's right-handed
 - Orig. \$599.99

\$399.99

ONLINE ITEM
ID# 2212081



PLAY WHAT THE PROS PLAY

Titleist

NXT or NXT Tour

- NXT features long distance with soft feel
- NXT Tour features low spin and high velocity
- 12-ball pack

ONLINE ITEM
ID# 2182968

Pro V1 or Pro V1x

- Pro V1 features longer distance with superior feel
- Pro V1x features lower spin
- 12-ball pack

ONLINE ITEM
ID# 1453384

SEE STORE FOR PRICES

THE NAME OF A WINNER

SAVE 50%
WHEN PURCHASED AS A PACKAGE

Your Choice

A. XL 2000 Ti Distance Double 15-Ball Pack

- Explosive distance combined with soft feel

B. Revolution Solid XT Double Dozen

- Larger core with a softer cover provides increased distance with improved spin

\$19.99

If purchased separately a \$39.99 value

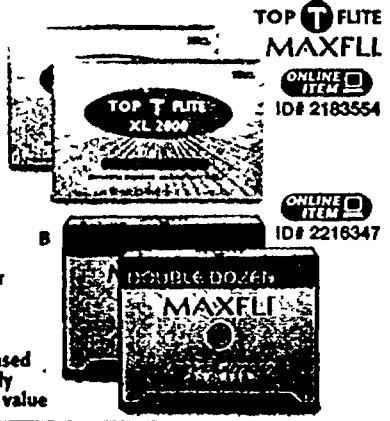

Championship Season

Winning is everything.

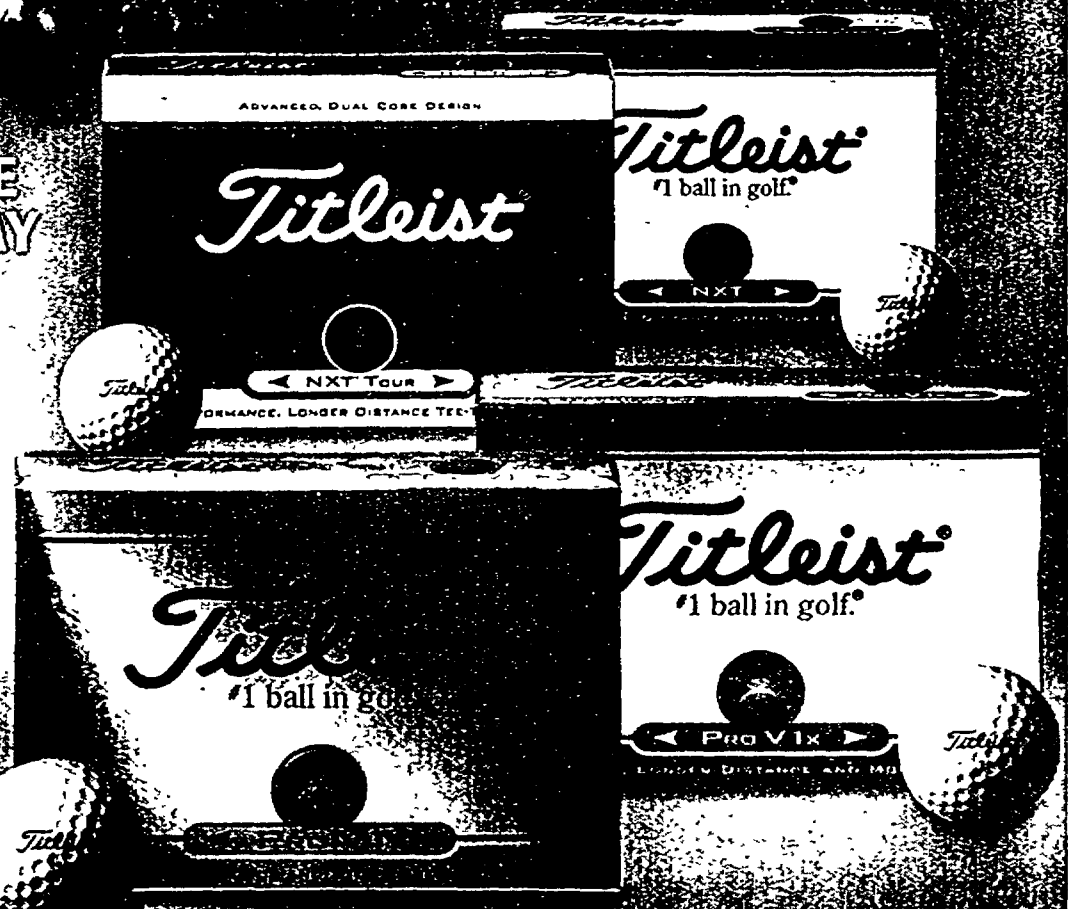

SAVE \$110

2 FOR \$150

Men's Tour Stop

LIFETIME WATERPROOF WARRANTY

Callaway

DICK'S EXCLUSIVE

TAYLORMADE'S
FIRST 460cc
FIXED-WEIGHT DRIVER
A. r5 XL 460 Ti Driver

- Pre-set, fixed weights offer choice of neutral or draw
- Fujikura Hyperlite XL shaft
- Men's right- and left-handed
- Women's right-handed

\$299.99

Your Choice

B. r5 XL Fairway Wood

- 3, 5 or 7 wood
- Fujikura Hyperlite XL shaft
- Men's right- and left-handed
- Women's right-handed

C. r5 XL Hybrid

- Fujikura Hyperlite XL shaft
- Men's right- and left-handed
- Women's right-handed

\$179.99

TaylorMade

Callaway
GOLF

THE TOOLS OF A WINNER

EDITORS CHOICE

SasQuatch SQ
460 Driver

- Diamana graphite shaft
- Men's right-handed
- Men's left-handed and Women's right-handed available in select stores

\$299.99

ONLINE ITEM ID# 2166266

SAVE 60%
OFF ORIG.

ADJUSTABLE WEIGHTS
AWS Driver

- 440cc dubhead
- Graphite shaft
- Men's right-handed

\$149.99

SAVE 25%
OFF ORIG.

RX Driver

- 460cc dubhead
- Graphite shaft
- Men's right-handed

\$299.99

SAVE \$50
OFF ORIG.

Rescue Mid

- Replaces long irons
- Available in various lofts
- Steel shaft
- Men's right-handed

\$99.99

SAVE \$100
OFF ORIG.

Big Bertha 04 Irons

- 4-10W • Steel shaft
- Men's right- and left-handed

\$499.99

SAVE \$40
OFF ORIG.

Your Choice
A. Riviera Wedge

- Right-handed

B. DFX Putter

- Available in various designs
- Right-handed

\$59.99

ONLINE ITEM

ID# 2142347

r7 460 Driver

- 16 grams of movable weight
- Fujikura RE*AX graphite shaft
- Men's right-handed

\$399.99

SAVE 50%
OFF ORIG.

GT Xtreme 2 Driver

- 430cc dubhead
- Heel and toe weighting helps square the clubface
- Graphite shaft
- Men's right-handed

\$199.99

SAVE 35%
OFF ORIG.

CG-6 Driver

- Graphite shaft
- Men's right-handed

\$199.99

SAVE \$70
OFF ORIG.

WH22 Hybrid

- Replaces long irons
- Available in various lofts
- Graphite shaft
- Men's right-handed

\$199.99

SAVE \$150
OFF ORIG.

SB3 Irons

- 5-PW stainless-steel irons
- Includes 2 WH22 hybrids
- Men's right-handed

\$299.99

BUY ONE
GET ONE
FREE*

A10 Wedges

- Forged stainless steel
- Available in various lofts
- Men's right-handed

Reg. \$99.99 each

MAXFLI

NEW FOR 2006

A. X460 Driver

- Graphite shaft
- Men's right- and left-handed
- Women's right-handed

\$299.99

SAVE \$30
OFF ORIG.

B. Big Bertha
Heavenwood

- Graphite shaft
- Men's right- and left-handed
- Women's right-handed

\$149.99

C. X-18 Irons

- 3-PW • Steel shaft
- Men's right-handed

\$699.99

COBRA

NEW FOR 2006
A. Speed Driver

- Choose from X, F and M styles
- Aldia graphite shaft
- Men's and Women's right-handed

\$399.99

B. Baffler Hybrid

- Replaces long irons
- Large face area for an expanded sweet zone
- Graphite shaft
- Men's right-handed

\$149.99

C. Inertia 3100 Irons

- 3-PW • Steel shaft
- Men's right-handed

\$449.99

Inertia 3100 Graphite Irons...\$49.99

MAXFLI

BUY ONE
GET TWO
FREE*

A10 Ti Drivers,
Fairway Woods
and Hybrids

- Men's 460cc or Women's 430cc driver
- Graphite shaft
- Men's right- and left-handed
- Women's right-handed

Reg. \$59.99-199.99 each

Bushnell Yardage
Pro Sport
Range Finder

- 149.98
- Now legal for golf

Reg. \$159.99

Online ID# 2001500

DICK'S
SPORTING GOODS

Key Contact Info

TO FIND A STORE NEAR YOU:
1.866.819.0038
DicksSportingGoods.com

CUSTOMER SERVICE:
1.866.677.4771
CustomerService@dcs.com

SHOP BY PHONE or ONLINE:
1.877.846.9997
DicksSportingGoods.com

\$29.98

Pro Series Cart Bag or Stand Bag

- Lightweight design • 7-way top
- 3 full-length dividers
- Orig. \$49.99 Now \$29.98
- ✓ Double ScoreCard Points

SAVE
50%
OFF ORIG.

COMBO SETS • BAGS • CARTS



✓ Double
ScoreCard Points

HAGEN JR. GOLF CLUBS

IT'S AS EASY AS 1 - 2 - 3

- 1 Hagen Jr. I - Fits Players
Ages 2-5, 45" and under
Orig. \$99.99

\$69.99

- 2 Hagen Jr. II - Fits Players
Ages 6-9, 45"-53"
Orig. \$149.99

\$119.99

- 3 Hagen Jr. III - Fits Players
Ages 10-13, 53" and over
Orig. \$149.99 (shown)

\$119.99

Walter Hagen
Varsity Combo...199.99

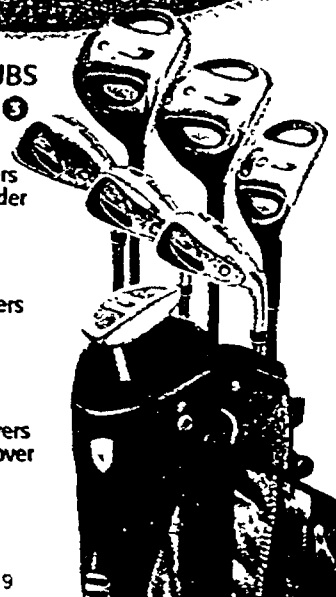

SAVE \$100
OFF ORIG.

13-PIECE SET Master Bear Set

- 460cc driver with adjustable weight system • Men's right- and left-handed
- Orig. \$299.99

\$199.99

SAVE \$150
OFF ORIG.

✓ Double
ScoreCard Points

HiperMax Deluxe Set

- 21-piece set • Graphite shafts • Deluxe cart bag
- Men's right- and left-handed
- Women's right-handed
- Orig. \$399.99

\$249.99

SAVE \$100
OFF ORIG.

✓ Double
ScoreCard Points

Trutech Combo

- 17-piece set • Cart bag
- Men's right- and left-handed
- Women's right-handed
- Orig. \$249.99

\$149.99

Your Choice

✓ Double ScoreCard Points

A. Men's or Women's Position Stand Bag

- 14-compartment top with 3 full-length dividers • Includes rainhood
- Orig. \$159.99

✓ Double ScoreCard Points

B. System Cart Bag

- 14-way organizer with 3 full-length dividers • Includes rainhood and insulated beverage holder
- Orig. \$159.99

C. Ultralight Stand Bag

- Ultralight construction
- Online ID# 2176587

\$79.99

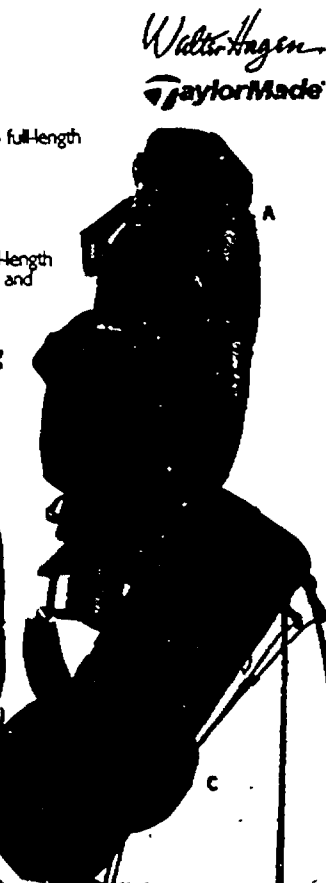

SAVE 50%
OFF ORIG.

RCX Stand Bag

- 8-way organizer top with 2 full-length dividers
- Includes rainhood
- Orig. \$99.99
- ✓ Double ScoreCard Points

\$49.99

SAVE \$80
OFF ORIG.

Your Choice

XTreme Sport Stand Bag (shown) Orig. \$109.99

- Online ID# 1930407
- ✓ Double ScoreCard Points

\$99.99

TAKE \$10 OFF

All Cart and Travel Covers

\$49.99 or more

ONLINE ITEM ID# 2274871



GOLF BALLS

SAVE 50%
WHEN PURCHASED AS A PACKAGE

ONLINE ITEM ID# 2261285

If purchased separately a \$39.99 value

Distance SFT Double Dozen

- Low-compression core for low spin and long distance

\$19.99

Your Choice

- A. RD Speed
• 12-ball pack

- B. RD Tour
• 12-ball pack

\$19.99

Your Choice

- A. Noodle Long & Soft
• 12-ball pack

- B. Noodle Noodle
• 12-ball pack

Online ID# 2224164

\$15.99

Your Choice

- A. Gold

- 15-ball pack
- Includes FREE 3-ball sleeve of Pinnacle Exception

- B. Warbird

- 12-ball pack
- Online ID# 1264602

\$14.99

SAVE 35%
OFF ORIG.

MC Distance

- New design features a large, muscle fiber core
- Low spin off the driver for greater roll • 12-ball pack
- Orig. \$19.99 each
- Now \$9.99 each

\$9.99

Pink

- Super-soft core and cover for high trajectory and long distance
- 12-ball pack

\$14.99

Noodle Ice...15.99 Orig. \$19.99
Online ID# 2143903

SAVE 35%
OFF ORIG.

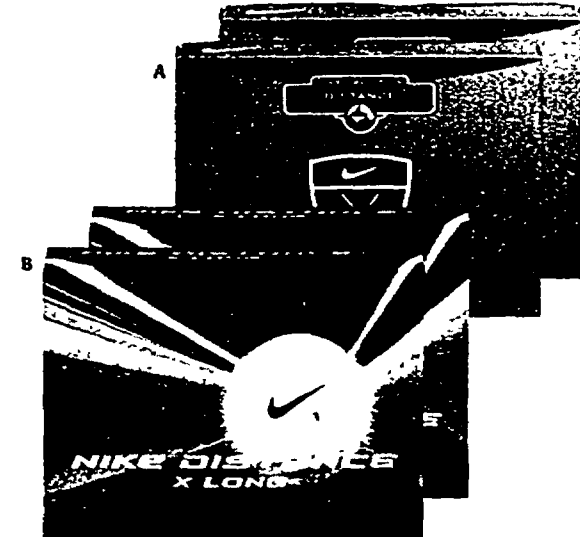

A. Precision Distance

- 2-piece ball • Reduced side spin for straighter shots • 12-ball pack
- Reg. \$14.99 each

B. Distance X Long

- NDX core and cover for long, straight shots and soft feel
- 12-ball pack
- Orig. \$19.99 each
- Now \$14.99 each

ONLINE ITEM ID# 2118590

Your Choice

\$20.99

Your Choice

A. One Platinum 2006

- Longer distance and higher trajectory
- 12-ball pack
- Online ID# 2039931

B. One Black

- Improved speed and distance with lower spin
- 12-ball pack
- Online ID# 2224156

C. HX Tour 56

- Reduced driver spin for longer, straighter shots
- 12-ball pack
- Online ID# 2178856

D. HX Tour

- 3-piece construction
- Thin cover offers distance and short-game control
- 12-ball pack
- Online ID# 2192868

\$39.99



Shop us online at DicksSportingGoods.com or order by phone at 1.877.846.9997

DICK'S
SPORTING GOODS

EVERY SEASON STARTS AT

DICK'S
SPORTING GOODS



\$29.99

Men's or Women's
Pro Series

- Cushioned insole
- Padded collar and tongue
- Engineered EVA midsole
- Breathable mesh

SAVE
50%
OFF ORIG.



GLOVES • HATS • APPAREL

APPAREL

FOOTWEAR

SAVE 40%
OFF ORIG.

✓ Double
ScoreCard Points



Men's and Women's
Tour XI Gloves

- 100% Cabretta leather ensures responsive touch and grip
 - CoolMax Lycra wicks away moisture and improves fit
- Orig. \$16.99 each
Now 12.99 each

3 FOR \$30

Walter Hagen



SAVE 33%
OFF ORIG.

✓ Double
ScoreCard Points

Men's Walter Hagen
Performance Polos and Shorts

- 100% Peruvian pima cotton polos available in solids and stripes • Enhanced moisture-wicking construction • Shorts available in a variety of colors
- Reg. 45.00 each

2 FOR \$60



Walter Hagen



SAVE UP TO \$50
OFF ORIG.

Your Choice

2-YEAR
WATERPROOF
WARRANTY

A. Men's
Comfort Saddle

- Soft, waterproof full-grain leather upper
 - Oversized spikes provide superior traction
- Orig. \$99.99

✓ Double
ScoreCard Points

2-YEAR
WATERPROOF
WARRANTY

B. Men's Fairway

- Premium waterproof full-grain leather upper
- Orig. \$79.99

\$49.99



Callaway
GOLF

Walter Hagen



SAVE UP TO 50%
OFF ORIG.

SAVE 45%
OFF ORIG.

Men's and Women's
Accufit Gloves

- Tournament Cabretta leather
 - Hydrolyte breathable microfiber
- Reg. 12.99 each

3 FOR \$20

Walter Hagen Jr. Gloves
3 for \$15 Reg. 9.99 each



✓ Double
ScoreCard Points



SAVE 50%
OFF ORIG.

Men's Tour
LTD Glove

- Cabretta leather
 - CoolMax mesh
 - Flex-fit design
 - No rainchecks
- Orig. \$19.99

\$9.99



Save on Select Nike Golf
Apparel and Outerwear

- Choose from a variety of colors and styles
 - Selection varies by store
- ONLINE ITEM ID# 2280782
Sale 23.98-129.99
Orig. \$30.00-180.00
Now 30.00-129.99

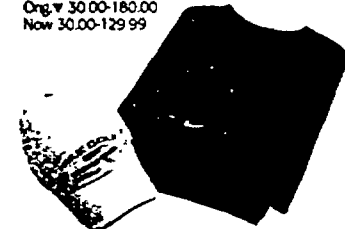

Save on Select Callaway
and adidas Golf
Apparel and Outerwear

- Choose from polos, shorts and outerwear in a variety of colors
- Sale 27.98-78.78
Reg. 35.00-98.50



SAVE 33%
OFF ORIG.

Your Choice

Men's or Women's
GreenJoy

- Closeout styles #45439, 48744, 45413 and 40407 (shown) Orig. \$49.99
- Online ID# 1875515

OR Men's SP3 (not shown) Orig. \$59.99

\$39.99



SAVE \$40
OFF ORIG.

✓ Double
ScoreCard Points

Your Choice

A. Men's Hybrid II

- 3-year waterproof warranty

B. Men's Euro

- 3-year waterproof warranty
- Orig. \$99.99

\$59.99



SAVE 20%
OFF ORIG.

All Golf Hats
and Visors

Sale 11.98-23.98
Reg. 14.99-30.00

ONLINE ITEM ID# 2204699

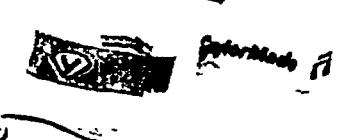

SAVE 50%
OFF ORIG.

All Men's Acuity Outerwear

Full-Zip Waterproof Rainsuit... 39.98
Orig. \$79.99 Now 59.99

2-Piece 1/2-Zip Rainsuit... 29.99
Orig. \$59.99

Nylon Windshirt 19.98
Orig. \$39.99 Now 29.99

Windvest 14.98
Orig. \$29.99 Now 19.99



SAVE 20%
OFF ORIG.

✓ Double
ScoreCard Points

Men's Acuity Pique Polos
and Shorts

- Moisture-wicking design keeps you cool on the course
 - Polos available in solids and stripes
- Reg. 19.99 each

2 FOR \$30



ONLINE ITEM ID# 1840408

Men's Under Armour
Performance Polo

- Durable, lightweight stretch fabric wicks away moisture
- Available in a variety of colors

3 FOR \$30

UNDER ARMOUR
heatgear
loosegear



SAVE \$30
OFF ORIG.

Men's or Women's
Sierra Treks

- 1-year waterproof warranty
 - Full-grain leather upper
 - Closeout styles #58946 and 98407
- Orig. \$99.99

\$69.99



Your Choice

A. Men's X-Dimension

- 2-year waterproof warranty
 - Closeout styles #53125 and 53133
- Orig. \$119.99

B. Men's eComfort

- 1-year waterproof warranty

\$79.99



Shop us online at DicksSportingGoods.com or order by phone at 1.877.846.9997

*In-store markdowns may have been taken

\$29.98

Men's Tech Polo or Polynolic Polo

- Moisture wicking
- Enhanced hydro-wicking
- Moisture wicking construction

SAVE 45%
OFF ORIG.



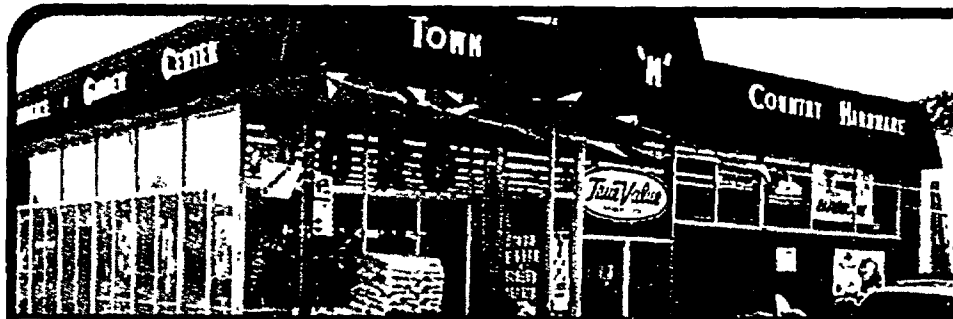

Sale Ends July 8, 2006

True Value

START RIGHT. START HERE.™

TOWN 'N' COUNTRY
FIREPLACE • PATIO • GRILLS



COURTYARD CLASSICS

Starting At
\$229

5-Pc. Park Ridge
Patio Set
Does not include umbrella or base.



King Canopy
Shade Products

Starting At
\$699

King Canopy
Awning
Model 1210PG



True Value.
19⁹⁹

From
Easy Kare Flat Interior Paint
Gal.-washable flat finish, ideal for
walls and ceilings. Easy soap and
water clean-up. Quick drying/non spatter
formula. 15-Year warranty. White. 354-217
Eggshell Gal.-22.99 463-851
Satin Gal.-23.99 258-916
Semi-Gloss Gal.-24.99 358-556

FREE
Cover with
purchase of
any Weber®
Gas Grill
Ends 7/3/06

Starting At
\$299

Toro Mowers
6.5-HP. Features the comfort of a
two-year guaranteed- to-start (GTS™)
engine promise and the patented
Personal Pace self-propel system.
Recycler cutting system
with Atomic® blade.
Mulch, side discharge
and rear bag.
Model 20005



TORO

www.Toro.com

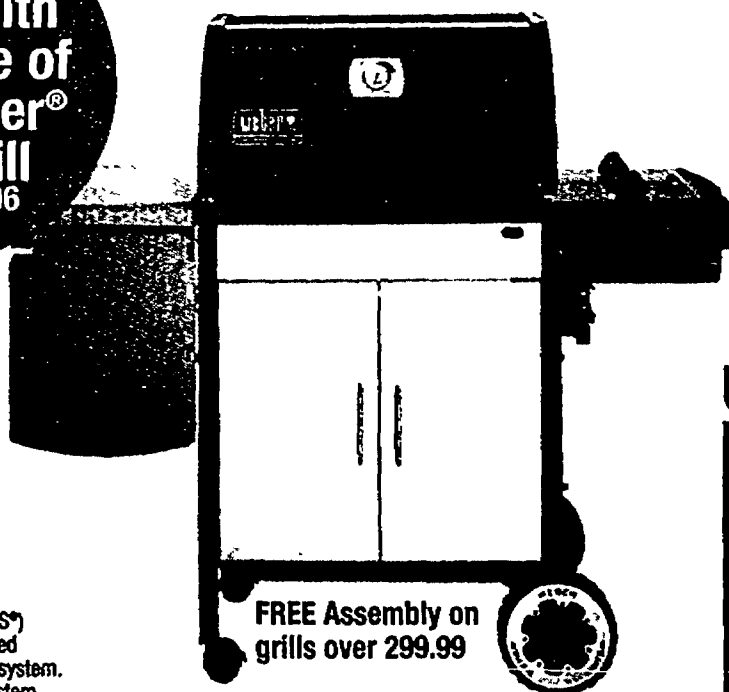

FREE Assembly on
grills over 299.99

weber **\$149**
Grills From

Weber Silver A Gas Grills 26,000- BTU's.
528-Sq.-in. cooking area. Includes 2 stainless
steel burners.

\$419

534-834 (As shown.).....

COUPON

\$2 Off
Next Propane
Tank Fill

True Value. Town 'N' Country
Expires 7/8/06

COUPON

20% Off
Gas Grill
Replacement
Part
(Limit 1)

True Value. Town 'N' Country
Expires 7/8/06

COUPON

1¢ With Any Purchase
of \$5.00 or more
Gas Lighter
Limit 1, with coupon
per customer.

True Value. Town 'N' Country
Expires 7/8/06

4th
OF JULY Savings!

Entering the GRILL ZONE!

BROILMATE
PREMIUM GAS

Starting At
\$685

Premium Gas Grill
40,000-BTUs.
Lifetime warranty.
Model P3F

For Serious Grillers

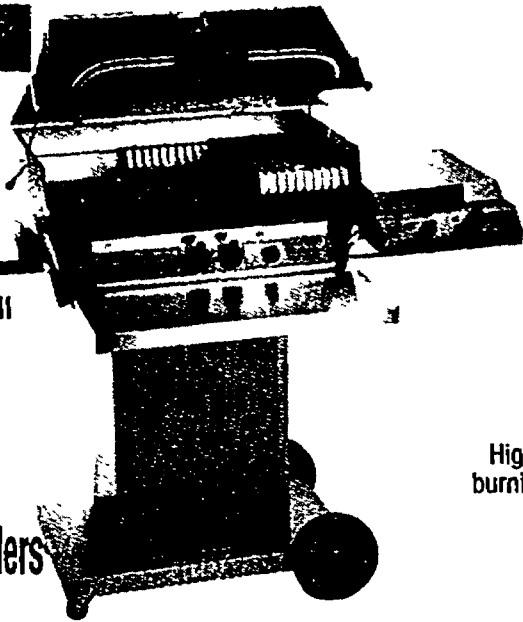

LARGE
Selection
of Solaire
Infrared
Propane
Grills

Solaire
INFRARED GRILLING SYSTEM

Starting At
\$329

Premium Grill
High quality stainless steel. 1600°-
burning temperature. Infrared burners.

AS SHOWN
\$4190

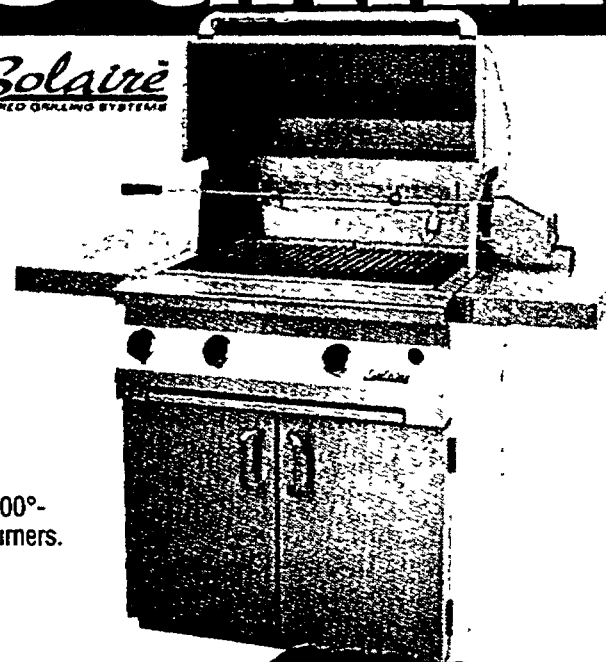

Starting At
\$499

The Big Green Egg
Smoker & Grill
It's a complete cooker
with unmatched
flexibility of use from
grilling, barbecue,
smoking, and baking
at exact temperatures
all by adjusting the
dampers.

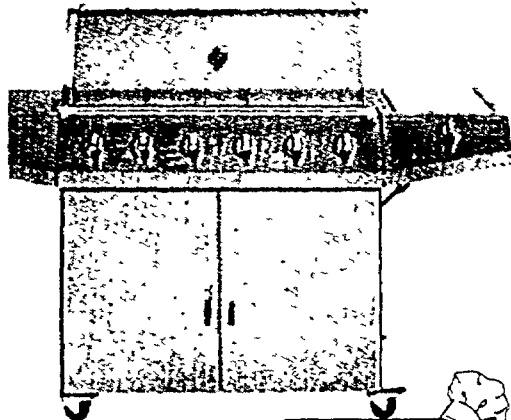

\$649

6-Burner Gas Grill
60,000- BTU's total, 12,000- BTU's cast iron
side burner with brass insert. 876- Sq.- In.- of
total cooking surface. Rotisserie burner and
rotisserie kit included. Model 810-6650-T
594-596

**GRILL
ZONE.**

COUPON

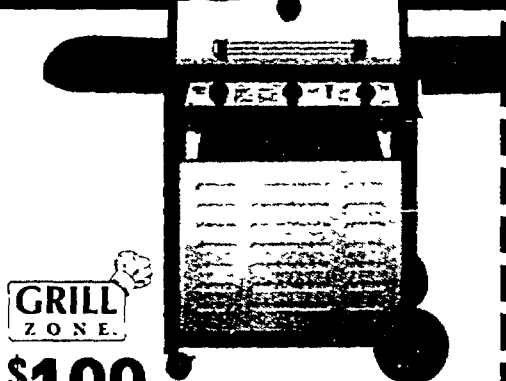

**GRILL
ZONE.**

\$199

3-Burner Gas Grill
15,000- BTU's each, 45,000- BTU's total.
620-Sq.-In. of total cooking surface.
Insulated stainless steel hood with die cast
aluminum end caps & stainless steel handle.

True Value. Town 'N' Country Expires 7 8 06

broil-mate



\$199

Broil-mate® LP Gas Grill
40,000-BTU stainless steel Dual-H burner.
580-Sq.-In.- total cooking surface. Model 13864

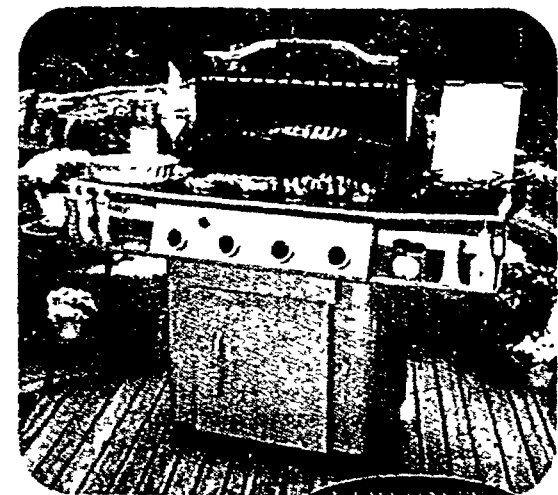

\$499

From
Full Line Of Vermont Castings
Signature Line Grills
Pop-up grill surface light. Natural Gas
models available.

COUPON

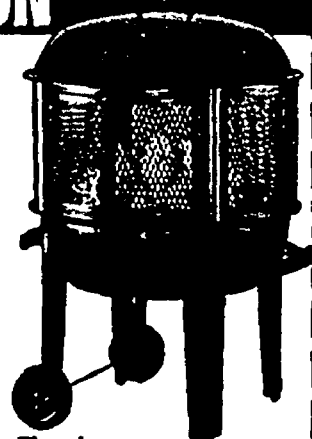

Coleman

99⁹⁹

28"-Round Patio Fireplace
With wheels. Black. Can be moved easily. Perfect
for patios, backyards and other outdoor activities.
Includes FREE cover. Model 5068-725 183-798

True Value. Town 'N' Country Expires 7/8/06



LANDMANN

149⁹⁹

Stars & Moon Fire Pit
Unique sand painted finish & stylish side
cutouts create an incredible fire ambiance at
night. Model 28375 533-374

We Carry A
Full Line of



\$295

Mosquito Magnet Defender
Features 24- hour protection up to 1/2-acre. Easy
to bury low 12V power cord. Silent and odorless.
Tank not included. Model DEFENDER

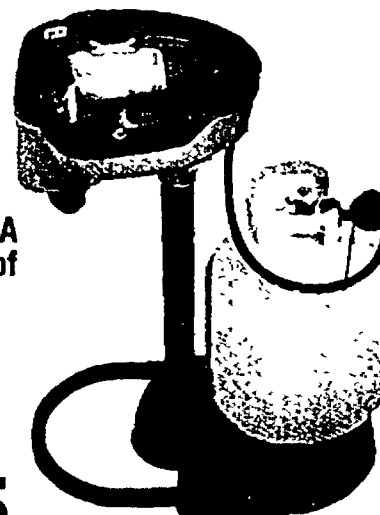

Starting At

\$549

Heritage Series Gas Grill
451-sq.-In.- total cooking area. 30,000- BTU.
Stainless steel cooking grids. Model JNRY00

weber

GO GRILL CRAZY!

Available
in Propane
& Natural
Gas



\$549

Weber® Flame™ Fireplace
Stainless-steel burner. Adjustable fiber/ceramic logs. Push-button ignition. Removable weather shields. Model 27000

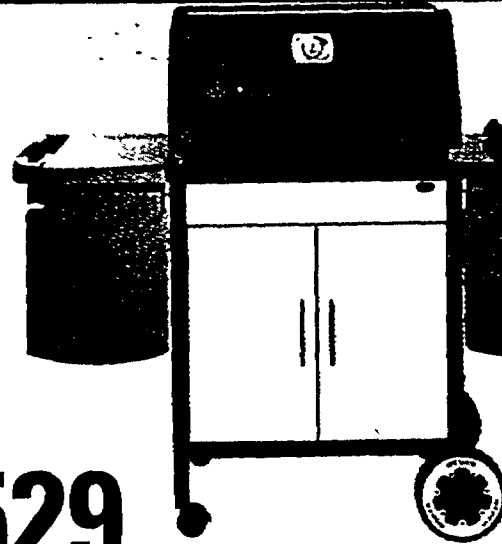

\$529

Silver "B" Premium Propane Grill
36,000 BTU. Includes 3 stainless-steel burners. Stainless-steel cooking grates & Flavorizer® Bars. Model 6721301 534-873

Available
in Propane
& Natural
Gas

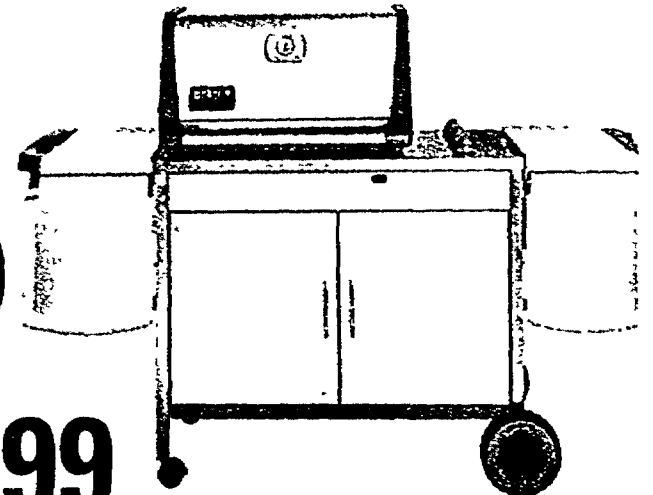

\$699

Platinum B Gas Grill
36,000 BTU's. Features a sleekly styled stainless-steel hood. Stainless steel frame. Natural gas available. Model 6770001 534-935
Side burner model available for \$50 extra.

34⁹⁹

Digital Thermometer
Easy-to-use remote. Clip the remote to your pocket or waistband. Model 32908
780-650

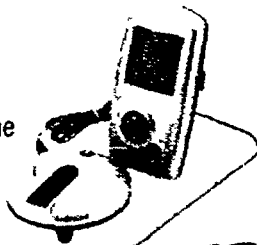

29⁹⁹

Poultry Infusion Roaster
Lower aluminum tray has a reservoir, cooks meat to perfection in less time than ordinary roasting. Poultry prop. Model 16129 248-799

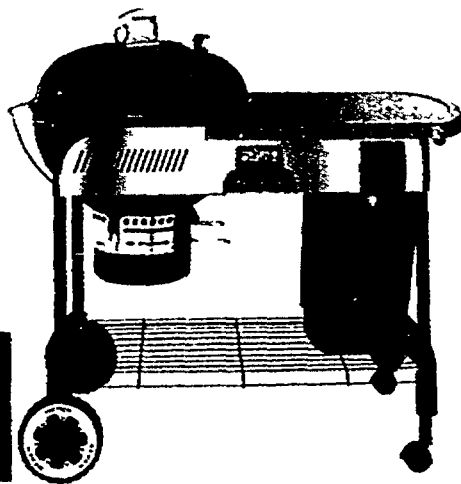

\$299

The Performer® Black Grill
Touch-N-Go gas ignition system ignites charcoal briquets with push of a button. CharBin storage container keeps up to 20-lbs. of charcoal dry. Available in Blue or Green. Model 841001 534-984

29⁹⁹

Three-Piece Stainless Steel Tool Set
Chef's tongs, barbecue fork, spatula. Model 18700 774-166

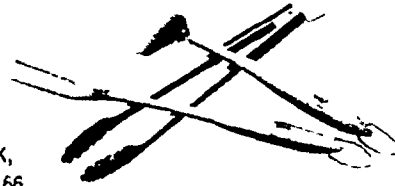

Now's the best time to start planning for your fall fireplace needs... **SUMMER SALE!**

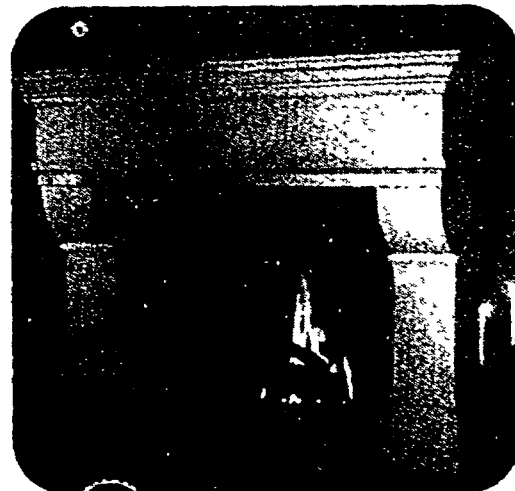

NAPOLEON

Direct Vent Gas Fireplace
A large showroom with a complete selection of vented and vent-free fireplaces on display. Model GD 80

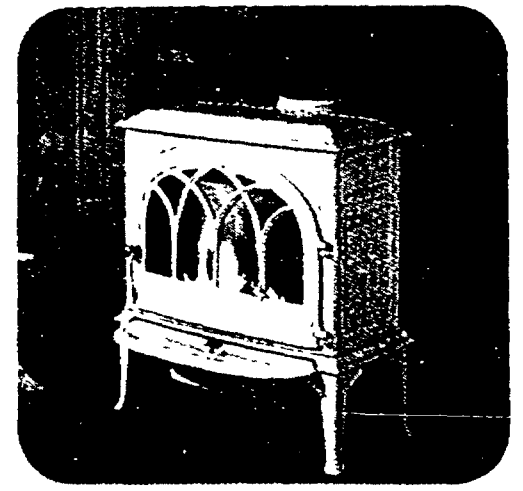

Wood Stoves
Starting At

\$649

As Shown **\$1499**

JÖTUL

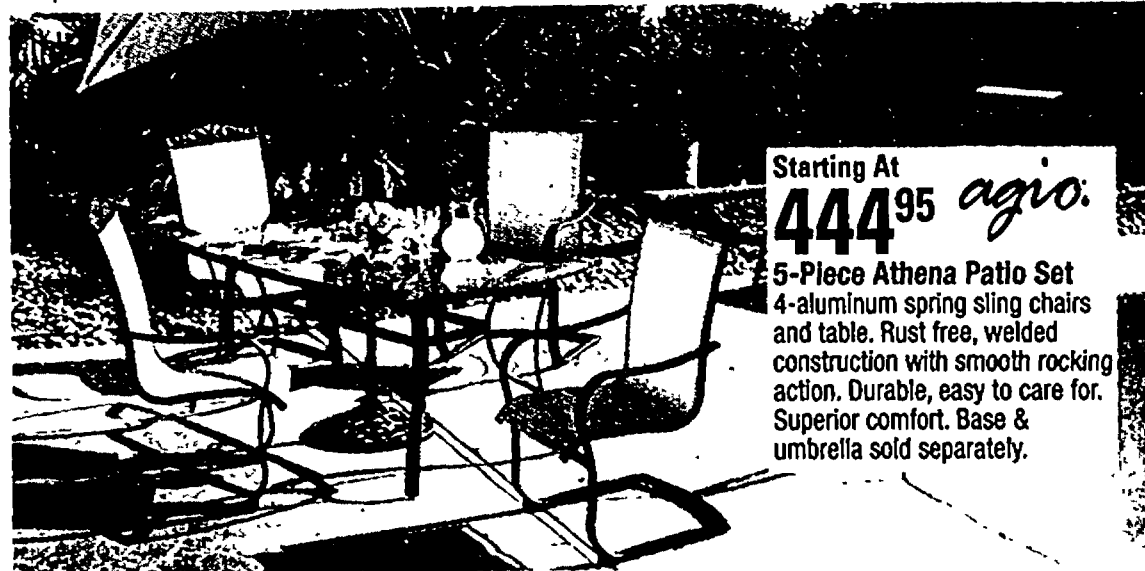

Starting At **444⁹⁵** *agio.*

5-Piece Athena Patio Set
4-aluminum spring sling chairs and table. Rust free, welded construction with smooth rocking action. Durable, easy to care for. Superior comfort. Base & umbrella sold separately.

20% OFF

Fireplace Tools
Heavy duty solid steel construction.

Starting At

39⁹⁹

Log Racks
Heavy duty.

In Stock Class A Pipe
Stainless Steel Chimney Pipe.

PANACEA



SELKIRK.

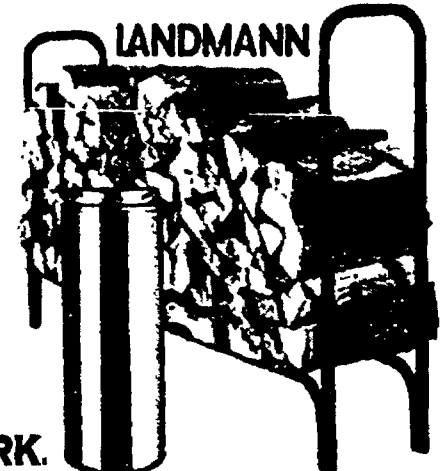

LANDMANN

True Value
START RIGHT. START HERE.

Start Your Summer Right!



549⁹⁹

Mini-Bikes 5"-wheels and engine mounted fuel tank. Reg. 659.00 Model STREAKER



499⁹⁹

Personal Pace Self-Propel Mower
Guaranteed-to-start (GTS®). Briggs and Stratton® engine. Super recycler cutting system. Premium cast aluminum deck. 3-in-1 mulch, side discharge and rear bag. 5-Year full warranty. Model 20055

TORO

www.Toro.com

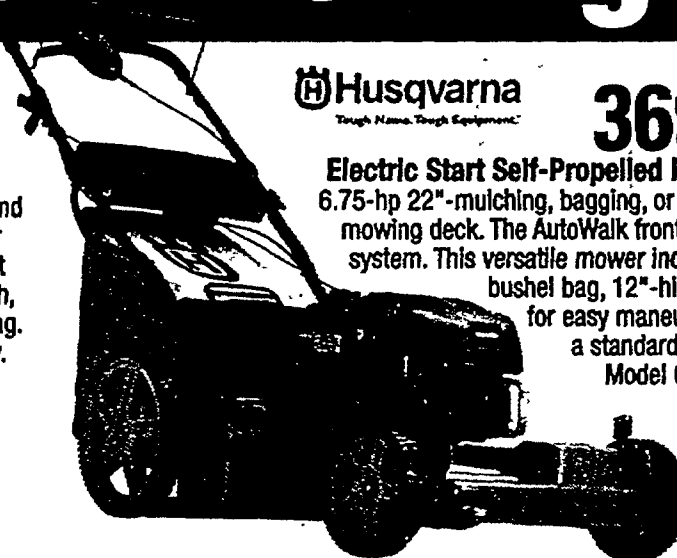

Husqvarna
Tough Name. Tough Equipment.

369⁹⁹

Electric Start Self-Propelled Push Mower
6.75-hp 22"-mulching, bagging, or side discharge mowing deck. The AutoWalk front wheel drive system. This versatile mower includes a 2.5-bushel bag, 12"-high rear wheels for easy maneuverability, and a standard mulch kit. Model 67522ES



149⁹⁹

Curved Shaft Trimmer
21.2cc-engine. This light weight, commercial grade trimmer is perfect for operators that demand maneuverability and comfort. Equipped with the world's easiest loading 2-line rapid loader trimmer head. Model GT200R

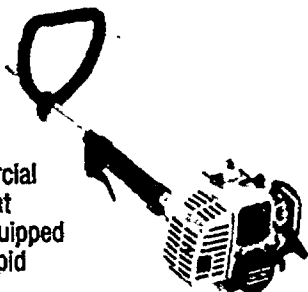

TORO

www.Toro.com

59⁹⁹

Electric Leaf Blower Vac
The Improved Super Blower Vac has more power (215 mph), a 2-speed motor, and even easier conversion between blowing and vacuuming. Model 51591 859-868



BLACK & DECKER

29⁹⁹

Hedge Trimmer
Compact and easy to use. Lock on button for continuous running. Lock off button prevents accidental starting, cord retention to prevent trimmer from coming unplugged and pre-hardened. Model TR1600 587-912

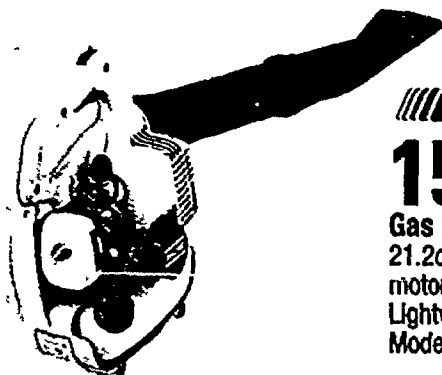

ECHO

159⁹⁹

Gas Powered Blower
21.2cc-engine. Low-vibration motor delivers 145-mph. Lightweight, easy-to-use. Model PB200

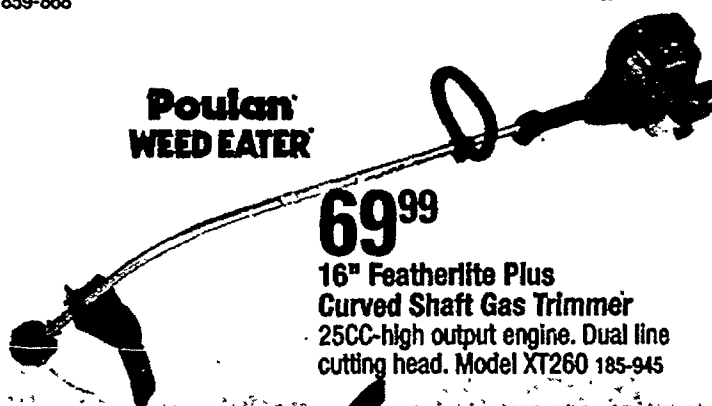

Poulan WEED EATER

69⁹⁹

16" Featherlite Plus Curved Shaft Gas Trimmer
25CC-high output engine. Dual line cutting head. Model XT260 185-945

79⁹⁹

EDGE HOG 2-In-1 Landscape Edger
11-Amp.-high torque motor tackles tough overgrowth creating a defined trench. Exclusive pull-up edge guide converts edger to landscape trencher. 3-position blade depth adjustment provides control of cut. Tool-free assembly offers quick, no hassle setup. Built-in cord retention secures extension cord. Model LE750 722-728

BLACK & DECKER



TOWN 'N' COUNTRY
FIREPLACE • PATIO • GRILLS



SPECIALISTS IN GRILLS & CUSTOM FIREPLACES.

True Value.

27740 Ford Road Garden City, MI 48135

(734) 422-2750

Store Hours: Mon. - Thurs. 9am - 8pm
Fri. - Sat. 9am - 6pm; Sunday 11am - 4pm

Town 'N' Country PAGE 4

✓ Check out these services we offer..

- Screen Repair • Window Shades Cut To Size
 - Pipe Threading • Window Repair
 - Keys Duplicated • Glass Cutting
- WE FILL PROPANE TANKS!**

In Your Neighborhood...

Make Town 'N Country
Your #1 Hardware Store.

We Have Over 68 Years Experience Providing
Quality, Service And Reasonable Prices.

Not responsible for typographical errors

Town 'N' Country-JULY

K
kmart

**BUY 4
12-PACKS,
GET A \$10
KMART GIFT CARD.**

(BY MAIL)

See store for details.



4 for \$10
SALE
12-pack Coca-Cola
12-oz. cans.
Assorted varieties.
Limit 4.

your 4th of July headquarters



30% off
SALE Men's and
women's hats,
women's belts
and totes
Excludes Team Sports hats

\$5
reg. 5.99-7.99
SALE
Patriotic tees
for men and women
Plus size, reg. 9.99,
sale \$7.

50% off
SALE Route 66®
men's 5-pocket
denim shorts
40% off other
men's shorts*
*Excludes Dickies®
Amelech® and
Team Sports shorts

\$8
reg. 12.99
SALE Basic Editions®
men's polos
Big men's sizes 2X-4X,
reg. 14.99, sale \$10.

GREAT SAVINGS ON FAMILY SUMMER FOOTWEAR

men's

women's



\$15 SALE Thom McAn® or Cobbie Cuddlers®
reg. 19.99-24.99 Men's or women's leather sandals

ThomMcAn.

cuddlers

Colors and assortment of merchandise
on this page may vary by store.

70% OFF FINE JEWELRY • 40% OFF STERLING SILVER JEWELRY

Fine Jewelry Policy: Ticketed prices reflect offering prices at which sales may or may not have been made. Sale does not apply to red-tag price-reduced clearance, gold-filled, family jewelry or class rings. Jewelry photos may be enlarged to show detail. Diamond weights are not exact. Jewelry shown is representative of assortment and may vary by store. If an advertised item is not available at your nearest store, we will be happy to order it for you. Sterling silver rings are not available by special order.

Prices effective Thursday, June 29 thru Tuesday, July 4, 2006

50% off
FAMILY
SWIMWEAR

Treat yourself to
lower prices this summer.



Modern life made easy.

Bundle WOW! Phone, High-Speed Internet and
Cable TV for just \$99.99*. Or, any two services
are just \$59.99*. Prices guaranteed until 2008.

WOW!SM
INTERNET · CABLE · PHONE

wowway.com

WOW! bundled services. Tempting, aren't they?

Get WOW! Phone, High-Speed Internet and Cable TV for \$89.99*
Or, take any two services for \$59.99*. Price guaranteed until 2008*

Call today to bundle WOW! Phone, High-Speed Internet and Cable TV for \$89.99. Or, take any two services for \$59.99.

It's all guaranteed - twice!

Your price is guaranteed until 2008 with no contracts to sign.

Plus, you'll get a 30-day money-back guarantee.

And, if you call before July 14, you'll get professional home installation for 50% off — a savings of \$19.99.

Choose your bundle.

WOW! also offers feature-rich phone packages, a choice of Internet speeds up to 6Mbps, digital cable and the latest in technology, like HDTV.

It's quick, easy and risk-free.



WOW! is "#1 in Customer Satisfaction Among Cable/Satellite TV Subscribers."

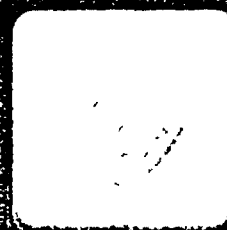
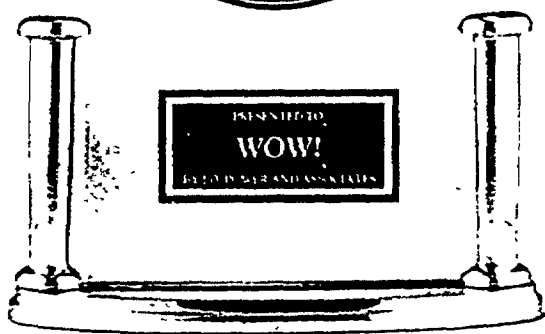

WOW!
Internet

- Unlimited local, nationwide long distance and local toll calling.
- Keep your current phone number or get a new one.
- Call Waiting, Call Forwarding, Call Return, 3-way calling and more.



WOW!
High-Speed
Internet

- A 112kbps high-speed Internet connection that won't tie up your phone line.
- 5 e-mail addresses and 10MB of webspace.
- Protection from unwanted spam and known viruses.

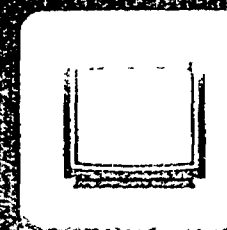

WOW!
Cable

- 75 popular cable channels including Hallmark, ESPN, TOONDisney, TLC and CNN.
- All your local broadcast stations.
- Access to pay-per-view movies, events and sports.

Call 1-800-877-8777 or visit us online at www.wowway.com by July 14, 2006

Modern life made easy.™

WOW!
INTERNET · CABLE · PHONE

wowway.com

Offer expires 7/14/06 and is available to residential customers located in WOW! serviceable areas. \$89.99 per month price is for WOW! Basic Cable, Basic Phone and 112kbps high-speed Internet service and is guaranteed until January 1, 2008. \$59.99 per month price is for any two of the following services: Basic Cable, Basic Phone or 112kbps high-speed Internet and is guaranteed until January 1, 2008. Price excludes modem lease of \$2.50 per month. You must own or lease a cable modem to receive WOW! Internet. *You must lease an advanced modem to receive WOW! Phone. An advanced modem will support both WOW! Internet and WOW! Phone. Unlimited local and long distance refers to U.S. nationwide calling. Certain phone features may not be available. See complete terms and conditions for further explanation and limitations regarding WOW! Phone. Actual Internet speeds may vary. Money-back guarantee available to first-time subscribers for first regular monthly charge for WOW! services (excluding equipment and pay-per-view charges). Offer not valid with any other discount. Offer and services subject to change without notice. Subject to all applicable taxes and fees. See WOW's complete terms and conditions or call WOW! for further information regarding all services and offer. ©2005 WideOpenWest Finance, LLC. J.D. Power and Associates 2005 Syndicated Residential Cable / Satellite TV Customer Satisfaction Study. Study based on 11,586 cable/satellite TV subscriber responses. www.jdpower.com.

JUNE 25 - JULY 1, 2006

American *Profiteer*



CRASH BANG ZOOM

The Schutte family's
demolition derby devotion

INSIDE:

- Fishkill, N.Y., declares America's independence
- Grandma Moses
- Pitcher punch

EMMY® AWARD WINNER PATRICIA AROUETTE

MEDIUM

SEE IT NOW ON LIFETIME

11pm/10c Sunday

Lifetime
LifetimeTV.com



Ask American Profile

Q: What can you tell me about Jim Cantore?

—Debra C. Tussey, South Lake Tahoe, Calif.

Cantore, a field weatherman who started working for The Weather Channel fresh out of college 15 years ago, frequently is dispatched to cover "extreme weather"—chasing tornadoes, riding out blizzards or waiting on monster hurricanes to make landfall. While he doesn't worry about being in harm's way, he knows his wife and two kids are concerned. "But they know that daddy won't be happy," Cantore says, "unless he's out swashbuckling in a storm."

Weatherman Jim Cantore

Weatherman Jim Cantore started working for The Weather Channel fresh out of college 15 years ago, frequently is dispatched to cover "extreme weather"—chasing tornadoes, riding out blizzards or waiting on monster hurricanes to make landfall. While he doesn't worry about being in harm's way, he knows his wife and two kids are concerned. "But they know that daddy won't be happy," Cantore says, "unless he's out swashbuckling in a storm."



Q: Is the Scott Grimes on ER the same Scott Grimes who has an album out?

—Mary Daly, Lebanon, Mo.

Yes, they are the same. Massachusetts-born Grimes, 34, began his career at age 10 as a singer on Broadway and later traveled with Bob Hope on USO tours. As an actor, he had roles on TV's *Party of Five* and *Band of Brothers* and in the movies *Crimson Tide*, *Critters* and *Mystery, Alaska*. Portraying Dr. Archie Morris on *ER* for the past three years, he's also managed to keep together a band, Scott Grimes and the Misdemeanors (of which his wife, Dawn, also is a member), touring and performing on weekends. Last year, Grimes released a CD called *Luvin' on the Run*.



Scott Grimes on *ER*

Q: I've fallen for Kari Matchett, who plays the brainy, beautiful Dr. Underlay on *Invasion*. What can you tell me about her, including how to correctly pronounce her name?

—S. Cherry, Findlay, Ohio

The *Invasion* actress (who pronounces her name KAH-ree MATCH-it) was born in rural Spalding, Saskatchewan, where passing motorists today can see a sign welcoming them to her birthplace. Matchett, 35, attended theatrical school in Montreal and later Russia, and began working almost immediately after graduation in television on the A&E mini-series *Five Days to Midnight*, the CBS movie *A Very Merry Christmas*, the Sci-Fi Network series *Earth Final Conflict* and the FOX-TV series *Wonderfalls*. For her biggest role yet, in the aliens-among-us series *Invasion*, she relocated earlier this year to Los Angeles, where she enjoys running, yoga and living half a block from something she never had back in Saskatchewan: a beach. ☆



Kari Matchett stars in TV's *Invasion*.

Q: What can you tell us about Guy Mitchell?

—Mary Bona, Sequim, Wash.

Mitchell, whose 1950s hits include "My Heart Cries for You" and "The Roving Kind," was born Al Cernick in Detroit, the son of Yugoslavian immigrant parents. His last No. 1, "Heartaches by the Number," came in 1959. He also had a handful of acting roles, most notably in the movies *Those Redheads from Seattle* (1953) and *Red Garters* (1954). He died in 1999 at age 72.



CMT

Bill Engvall Hosts Country Fried Videos

Good ol' greasy fun is the premise of CMT's *Country Fried Home Videos*, a new weekly series beginning June 30 at 9 p.m. ET/PT. Hosted by comedian Bill Engvall, the show features real videos shot by real people showing what real Americans do for offbeat entertainment—including mud-hole belly flopping, backyard "shotgun bowling" and bobbing for trout. It won't always be pretty... but it'll always be pretty funny!

■ **WHAT MAKES YOUR HOMETOWN GREAT?** *American Profile* wants to know in 200 words or less what makes your hometown great. You can tell us about your town's unique history, its current claim to fame, the wonderful townspeople, or simply explain the sense of pride you have from living there. The best responses will be featured in an upcoming story.

Mail submissions by Aug. 1, along with your name, address and telephone number to:
Hometown Great c/o *American Profile*, 341 Cool Springs Blvd., Suite 400, Franklin, TN 37067

* Cover photo by Ken Klotzbach

American Profile

Celebrating Hometown Life

President & CEO Richard G. Porter
VP/Group Publisher Tracey Atman
Executive Editor Charlie Cox
Senior Editor Stuart Engert
Editor Richard McVey
Entertainment Editor Neil Ponce
Assistant Editor Jane Srygley
Contributing Editors
Marti Atoun, Beverly Keel, Marta W. Alencar
Art Director Brenan Sharp
Publication Designer ER Elliott
Photo Editor David Mudd
Production Manager Sam Payne
Traffic Coordinator Susan Fisher
Manager of Internet Content
Matt Johnston

ADVERTISING SALES

1-800-716-6271

National Ad Sales Director Amy Chernow
NEW YORK

Regional Ad Director Holly Brumbaugh
Account Managers Sharon Hay Sean White
CHICAGO

Midwest Ad Director Jeff Hopkins

Account Managers Priscilla Mack, Erica Schuler
Southeast/West Coast Ad Director Frank Zerby

Los Angeles Account Manager James Reilly
Director of Marketing Jeff Dunetz

Associate Director of Marketing Kelly Finto
Direct Response Advertising

Katherine Zito, David Geller Associates, Inc.
1-877-543-5537

CIRCULATION SALES

VP/Publisher Relations Jerry Lyess

Regional Circulation Director

Sand Baylis, Stephen Doms

Mike Gardner, Chns Kreidel

Nashville 1-800-720-6323

Director of Business Dev. Steve M... ..

CORPORATE & EDITORIAL OFFICES

Nashville 615-468-6000

PUBLISHING GROUP OF AMERICA

President & CEO Richard G. Porter

CFO & COO Stephen C. Duggan

VP/Controller Greg Coble

Network Administrator Mike O...

www.americanprofile.com

PUBLISHING GROUP OF AMERICA

American Profile is published by Publishing Group of America, Inc., 341 Cool Springs Blvd., Suite 400, Franklin, Tennessee 37067. Phone: (615) 468-6000. Mail editorial queries and correspondence to: American Profile, 341 Cool Springs Blvd., Suite 400, Franklin, TN 37067. Publishing Group of America, Inc. will not be responsible for a return of unsolicited materials, and cannot guarantee the return of any materials sent to it. © 2005 Publishing Group of America, Inc. American Profile is a trademark of Publishing Group of America, Inc. All rights reserved. Reproduction in whole or part of any article, photograph, or other content of this magazine, without the express written permission of the Publishing Group of America, Inc., is prohibited.

—YES! Please send me the Lassie 3 DVD Collector's Set for only \$24.95 + \$4.95 s/h (\$29.90 total)

Name _____
Address _____
City _____
State _____ Zip _____
Phone () _____

Residents of CA, TN, IL, AR and NY add state sales tax
NSF checks will be automatically debited for the amount of the check plus applicable fees. Order expires 8/25/06.
Please allow 2-4 weeks for delivery.

INTRODUCE YOUR CHILD OR GRANDCHILD TO AMERICA'S FAVORITE COLLIE...
Lassie is Back! 3 DVD
50th TV ANNIVERSARY COLLECTOR'S EDITION
24 of the Greatest TV Adventures
One of the Greatest TV Stars of All Time
OVER 8 HOURS OF FAMILY FUN!

Call (800) 715-6248
from 8AM - 5PM CT, M-F
or send check or money order for \$29.90
(24.95 + \$4.95 s/h) to Lassie - Dept AP,
P.O. Box 340, Harrison, AR 72602
www.americanprofile.com/store

For faster delivery, order online at www.dragonstoday.com

Winging their way
to you soon...

Set 2



Sea Singer,
Source of Renewal

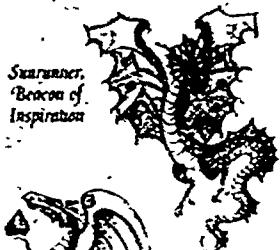

Starrunner,
Beacon of
Inspiration

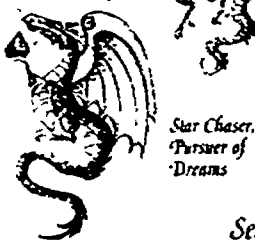

Star Chaser,
Pursuer of
Dreams

Set 3



Moonglow,
Light of Tranquility



QuickSilver,
Keeper of Secrets



Zephyr,
Spirit of
Transformation

Premiering at
Only

\$9.99*
each

plus shipping and
service charges
sold in sets of three

The Dragons of the Crystal Cave

Ornament Collection

Snow Star,
Protector of
Purity

Aurora, Guardian
of Hope

Ember, Spark
of Inspiration

Ornaments are approx.
5 1/2" to 6" high



THE ASHTON-DRAKE GALLERIES

9200 North Maryland Ave., Niles, Illinois 60714-1397

PLEASE RESPOND PROMPTLY

YES! Please reserve *The Dragons of the Crystal Cave* ornament collection for me. I will receive an invoice for the full amount due with each 3-ornament shipment. After I've paid for one set of 3 ornaments, the next set will be shipped to me automatically.

- SEND NO MONEY NOW • 365-DAY, MONEY-BACK GUARANTEE
- ONLY \$29.97* PER 3-ORNAMENT SET

Name (please print clearly)

Telephone

Address

Apt. No.

City

State

Zip

913070-D15201

*Total price of \$35.99 includes \$5.99 shipping and service charges. Sales tax additional on shipments to Illinois. Please allow 10 to 12 weeks for shipment after order is received. All orders are subject to acceptance. Price is higher in Canada.

Let your imagination soar...

...as the *Dragons of the Crystal Cave* take you on a journey into the mystical realms of true inspiration.

These magical dragons take wing and invite you to their wondrous world where they reign supreme. These fully sculpted resin ornaments feature sparkling scaly dragon "skin," hand-painted in iridescent colors, from the tips of their noses to the ends of their twisting tails. Translucent wings fan out above them, aglow with the look of stained-glass and highlighted with "gems." And each carries a glimmering "crystal" to lift the spirit and spark the imagination.

Soar with the *Dragons of the Crystal Cave* for just \$29.97* per set of three. You may cancel your subscription at any time. Order today!

Hometown Recipes

from J.B. ROBERT

Pitcher Punch

"When I was growing up in the 1950s, I spent my summers on my uncle's farm in New York state. At the end of a long, hot, dusty day in the fields, there was nothing better than my Aunt Alice's Pitcher Punch to cool you down and slake your thirst." ☆

RECIPE: Pitcher Punch

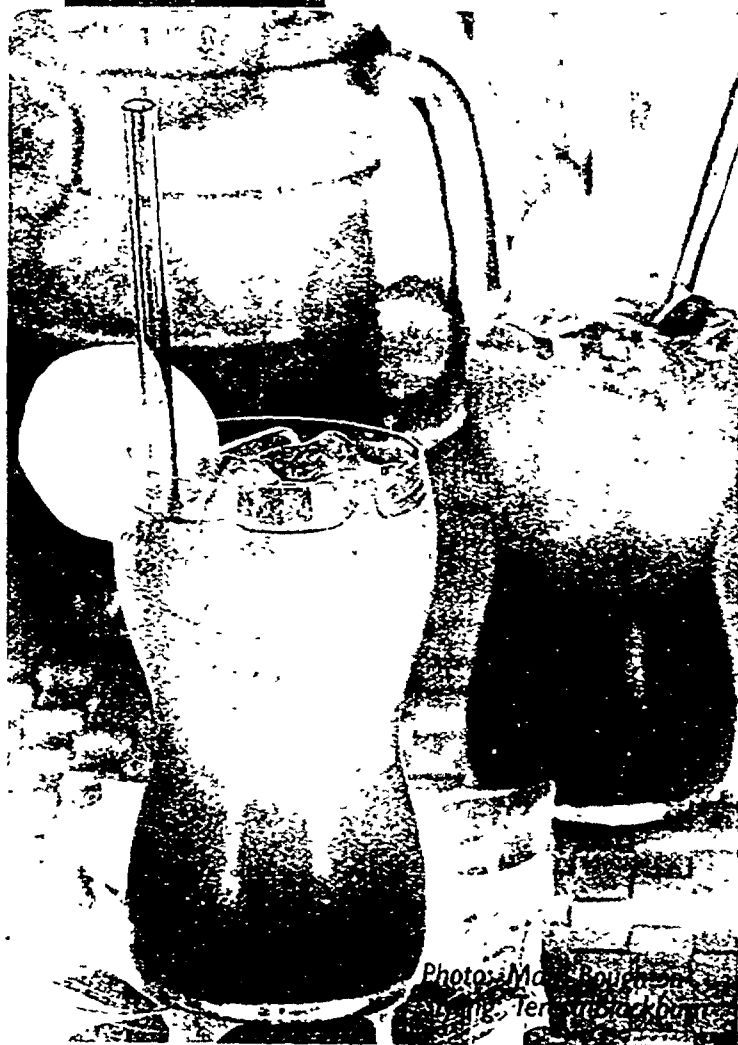

Pitcher Punch

- 4 cups water, divided
- 3 tea bags
- 4 lemons
- 1 and 1/2 cups sugar
- 1/2 teaspoon almond extract
- 1 teaspoon vanilla extract
- Dash of salt

American Profile



J. B. Robert Murphy, N.C.

Boil 2 cups water and pour over tea bags in a glass container. Steep for 20 minutes. Squeeze juice from lemons, reserving juice and rinds. In a large pot, bring remaining 2 cups water to a boil. Add lemon rinds to boiling water. Add sugar. Simmer until slightly thickened, about 10 minutes. Remove from heat and remove lemon rinds. Let cool. Squeeze and remove tea bags. Combine lemon-sugar syrup and tea. Strain reserved lemon juice and add to tea mixture along with vanilla, almond extract and salt. Mix well and refrigerate. To serve, pour 1/3 to 1/2 cup mixture over ice and top with about 1/2 cup of water. Yields 5 and 1/3 cups tea mixture.

Win a FREE Holiday Cookbook!

Whether it's Valentine's Day, Passover, Easter, 4th of July, Thanksgiving, Christmas, or any other holiday you celebrate, we want your special recipe! If chosen, we'll send you a FREE copy. Send us your recipe with a color photo of yourself, name, address and phone number. Please send a brief description of the recipe and how you celebrate the holiday, and note the holiday on the front of the envelope. Send to:

HOLIDAY COOKBOOK
341 Cool Springs Blvd., Suite 400
Franklin, TN 37067

All submissions and photos become the property of American Profile (Sorry we can't return any materials.) Deadline for submissions August 1, 2006 One recipe per envelope, please

"A Year To Remember" Personalized U.S. Coin Set

5 HISTORIC U.S. MINT COINS FROM THE YEAR OF YOUR CHOICE

Great for: Birthdays ■ Weddings
■ Anniversaries ■ Graduations ■ Holidays

This 5-coin set from the year of your choice is like a time capsule - you get a Genuine U.S. Mint half dollar, quarter, dime, nickel and penny - plus a detailed history of world events and fun facts from that special year. Each coin is hand-selected for quality, sealed in its own clear capsule and displayed in a beautiful display case. It's a wonderful way to recall important years, and an even better gift - friends and loved ones will have something that may appreciate in value for years to come. The American Historic Society is offering this collectible "A Year To Remember" coin set for \$19.95. Choose any year from 1934 to 2006 (excluding 1955 & 1975). Remember, many coins minted by U.S. government prior to 1965 have a high silver content. Supplies are limited. Act now!

Each Set Features:

- 5 Genuine U.S. Mint Coins
- Custom Display Case
- Each Coin In Its Own Protective Capsule
- Detailed Anthology Of Featured Year
- Certificate Of Authenticity

Your Choice of Years:

1934, 1935, 1936, 1937, 1938, 1939, 1940, 1941, 1942, 1943, 1944, 1945, 1946, 1947, 1948, 1949, 1950, 1951, 1952, 1953, 1954, 1956, 1957, 1958, 1959, 1960, 1961, 1962, 1963, 1964, 1965, 1966, 1967, 1968, 1969, 1970, 1971, 1972, 1973, 1974, 1976, 1977, 1978, 1979, 1980, 1981, 1982, 1983, 1984, 1985, 1986, 1987, 1988, 1989, 1990, 1991, 1992, 1993, 1994, 1995, 1996, 1997, 1998, 1999, 2000, 2001, 2002, 2003, 2004, 2005, 2006

Celebrate A Year Of Living!



ORDER TOLL-FREE **1-800-542-0114**

THE AMERICAN HISTORIC SOCIETY

SATISFACTION GUARANTEED
IF NOT DELIGHTED, RETURN YOUR PURCHASE FOR A PROMPT REFUND OF YOUR PURCHASE PRICE LESS P&H.

The American Historic Society

Box 9225, Dept. HM71-AB, Central Islip, NY 11722

Please rush me:

___HM71 "A Year To Remember" Coin-Set Only \$19.95

Add \$4.95 p&h per coin set. Indicate year(s) of remembrance _____

My check is enclosed for \$ _____ CT, FL & NY residents add sales tax

Charge my VISA™ MASTERCARD™ DISCOVER™ AMEX™

Card No. [] [] [] [] [] [] [] [] [] [] [] [] [] [] [] [] Expires ____/____

Name _____

Address _____

City _____ State _____ Zip _____

Visit our website for great free offers! WWW.AHS.COM

©2006 National Consumer Marketing, 580 South Research Place, Central Islip, NY 11722

New Advanced portable air cooler uses 75% - 95% less electricity than portable air conditioners

Save Money - Runs on only Pennies a Day

**HEPA
FILTER**

Now You Can Cool Your Air 12-20 Degrees and Purify Your Air Removing 99.7% of Particles AT THE SAME TIME

Cools Large Areas - 200 sq ft - Uses Only Water & Ice - No Venting

By B. Imboden

Believe it or not, there are people who can look forward to the heat of summer because they know they can:

- stay cool
- have their air purified
- and save money on their electric bill...

...all at the same time! What do they know that you don't? They are using the new CoolAir 3000 Air Cooler, an evaporative cooler, with a built-in HEPA filter. With energy costs skyrocketing, smart consumers everywhere are looking for reliable ways to stay cool, bypassing air conditioners which are expensive to buy and use a great deal of electricity.

That's why the CoolAir 3000 is so revolutionary. It is based on a basic technology that has been updated for 21st century living. To understand the many benefits of the CoolAir 3000 we've compiled the most asked questions so you will know exactly how it works and how it can keep you cool, clean your air and save you money.

Q. What is the technology behind the CoolAir 3000?

A. The CoolAir 3000 is an evaporative cooler which produces effective cooling by combining the natural process of water evaporation with a simple reliable air moving system, like a fan or a blower.

Q. How does evaporative cooling work?

A. If you wet your arm and blow air on it your skin feels cooler. That's evaporative cooling. In an evaporative cooler, outside air is pulled through moist pads where it is cooled by evaporation. Evaporation is an endothermic reaction, it absorbs heat. So the air that goes through the pads has had heat absorbed out of it. This cooler air is then circulated through the room by a blower. The pads are kept moist by the water you pour into the water tank.

Q. How effective is the evaporative cooling?

A. On the average, the CoolAir 3000 can lower the temperature 12-20 degrees. With optimum conditions, it can lower temperatures as much as 35 degrees. A great deal

depends on the humidity in the air. Evaporative coolers work best when humidity is below 50%.

Q. Why does an evaporative cooler save so much electricity?

A. Because the technology is so basic, the electricity is used mainly to run the fan or blower. This takes about the same amount of electricity as using a lightbulb. In air conditioning, for instance, the electricity must power a compressor which is much more complex and involves high energy usage.

Q. How does the CoolAir 3000 clean the air?

A. This is where new technology meets tried and true technology. We have added a HEPA (High Efficiency Particulate Filter) to the CoolAir 3000. This is a perfect addition to the CoolAir 3000 because the combination of the HEPA filter and the fan turns the CoolAir 3000 into an air purifier removing 99.7% of particles from the air. This includes dust, pollen germs, viruses, fungi, and pet dander. This is in contrast to the portable air conditioner which just recycles the same air over and over and over. You have probably heard that indoor air pollution is worse than outdoor air pollution. And closed-door/window air conditioning is one of the reasons for this discouraging phenomenon.

Air purifiers can cost hundreds of dollars but with one CoolAir 3000, you get a top quality air purifier as part of the package.

Q. Why would a person choose a CoolAir 3000 over a portable air conditioner?

A. The biggest reason is cost. The CoolAir 3000 costs under \$200 while portable air conditioners run between \$450.00 and \$799.00. As mentioned, air conditioners can also use at least 4 times as much electricity as air coolers.

In recent years people have become much more conscious of health enhancing features, so the addition of the HEPA filter is a major benefit for everyone who is trying to improve the quality of the air he

or she breathes safely and inexpensively.

The other big benefit of the CoolAir 3000 is that even though it can cool a large area, 200 square feet, it does not need a vent. All air conditioners, portable or not, must have a way to vent off hot air. You can put the CoolAir 3000 anywhere there is an outlet since there is no hot air to vent away. You can move it from room to room on its easy glide casters to fit your schedule and needs.

Q. Can I use the CoolAir 3000 in conjunction with other cooling devices?

A. That is the way many people are using the CoolAir 3000. People who have whole house air conditioning use the CoolAir 3000 in places where the air conditioning does not reach. Air coolers are perfect for the sun room where you can have the windows open and stay cool with the CoolAir 3000.

They are also great for the office, condo, RV and dorm room.

Q. Is the CoolAir 3000 easy to use?

A. Absolutely. All you do is add water and turn it on. Add ice for even cooler temperatures. A full tank can last over 24 hours even with continuous use. There is a handy water level indicator so you know exactly where and when to refill.

If you do not want to use the water cooling feature, the CoolAir 3000 can also function as a quiet, powerful 3-speed fan. The louvers on the front help you direct the air flow in the desired direction.

You also receive a remote control so you can use all the functions from the comfort of your easy chair or even from bed.

Q. How can consumers get a CoolAir 3000?

A. You can only get the CoolAir 3000 from International Home Shopping, by returning your Special Reader's Discount Coupon at right or by calling 1-800-466-9973. You can also visit us online at www.ihsmall.com.

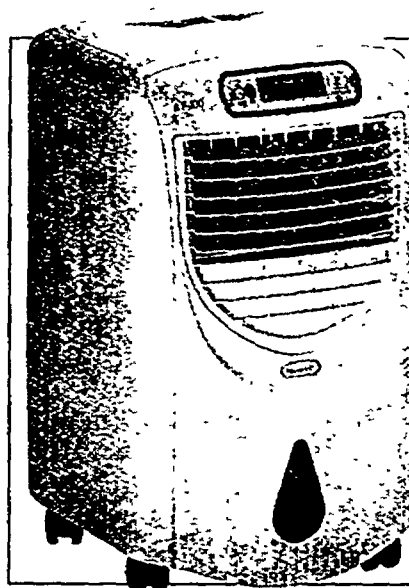

One Simple Unit - NO VENTING

- Easy-to-use controls
- Overall size 18" x 16" x 28"
- Oscillating function allows for more coverage - cools areas over 18ft away
- Special HEPA filter cleans 99.7% of particles in the air - dust, pollen, germs, virus, fungi
- Water tank capacity - 13 liters
Ice tank capacity - 4 liters
One fill-up lasts more than 24 hours of continuous use.
- Lightweight, moves from room on easy glide caster

Covered by: One Year Parts and Labor Warranty
60-Day Satisfaction Guarantee

Air Cooler - Air Conditioner Comparisons

Features and Benefits	Portable Air Cooler	Portable Air Conditioner
Cost Per Unit	under \$200	\$450 - \$799
Cooling Source	water, ice, fan	freon, compressor
Venting	no vent needed	needs to vent to outside
Cooling Ability	can lower temp. average of 12-20 degrees high of 35 degrees	can lower temp. to a thermostatically controlled temp
Home Prep	some windows open for air flow	windows and doors must be closed
Air Quality	HEPA filter purifies air removing 99.7% of particles*	recycles same air over and over
Electrical Usage	Runs on pennies a day	high electrical usage

* Air Coolers in general help freshen the air, but the CoolAir 3000 has the special HEPA filter to magnify this ability

SPECIAL READER'S DISCOUNT COUPON

The usual price to stay cool this summer and get the CoolAir 3000 is only \$189 (US) plus \$19 shipping for a total of \$208 delivered. Readers of this publication get a \$40 discount with this coupon and pay only \$149 plus receive FREE Shipping and Handling if you order within 10 days. Additional CoolAir 3000 air coolers are only \$129 each. There is a strict limit of 3 CoolAir 3000 at the discount price - no exceptions please. After 10 days, we reserve the right to accept or reject order requests at the discounted price.

- To order by phone, call TOLL FREE: 1-800-466-9973 Ext. PAC120. Place your order by using your credit card. Operators are on duty Monday - Friday 8am - 3am, Saturday 7am - Midnight and Sunday 7am - 11pm, EST.
- To order by mail, by check or credit card, fill out and mail in this coupon to the address below.
- To order online go to www.ihsmall.com

This product carries a complete satisfaction guarantee. If you are not totally satisfied your purchase price will be refunded. No questions asked.

NAME _____

ADDRESS _____

CITY _____

STATE _____

ZIP CODE _____

I am ordering within 10 days of the date of this publication, therefore I get a \$40 discount and my price is only \$149 for the CoolAir 3000 plus FREE Shipping and Handling. (CA 3000/VA)

Additional CoolAir 3000's are only \$129 each

Number of CoolAir 3000 air coolers you want _____

I am ordering past 10 days of the date of this publication, therefore I pay full price of \$189 for the CoolAir 3000 and \$17 Shipping and Handling. (CA 3000)

Enclosed is \$_____ in: Cash Check Money Order
(Make payable to IHS) or charge my

VISA MasterCard Am. Exp./Optima Discover/Novus

Account No. _____ Exp. Date ____ / ____

MAIL TO: International Home Shopping PAC120

7800 Whipple Ave. NW

Canton, OH 44707

IHS
INTERNATIONAL HOME SHOPPING
www.ihsmall.com



Crash Bang Zoom

Photos by Ken Klotzbach

by STEVE FANGE

The Schutte family's demolition derby devotion

Above: Cars collide during motorized mayhem at the Mississippi Valley Fairgrounds in Davenport, Iowa. Below, from left: Tory, Vicki, Ryan and Russ maintain the Schutte family's 38-year car-smashing tradition.



Russ Schutte, of Monroe, Wis. (pop. 10,843), sits behind the wheel of the 1976 Chevy Impala that he has spent hundreds of hours and a few thousand dollars rebuilding.

This is not, however, your average Saturday night car cruise.

Wearing his lucky helmet and his seatbelt, Russ, 52, shifts into reverse, guns the Chevy engine, and slams his back bumper into one of the dozen other cars circling the large dirt oval in front of the grandstands of the Mississippi Valley Fairgrounds in Davenport, Iowa, last September.

The other drivers, including Russ' younger brother, Tory, 34, do the same, and the cars—mostly 1970s sedans and station wagons—smash together in the kinds of crashes you'd normally only see in Hollywood action movies.

Mud from spinning tires flies into the stands and pelts some of the 1,000 fans. Flames shoot from exhaust pipes that stick straight up through holes cut into the car hoods. Steam and fluid spew from punctured radiators. Smoke billows from burning tires and failing motors. The crowd roars.

It's a familiar scene at county fairgrounds across the nation during the heart of the May-through-September fair season. Every year in the United States, an estimated 100,000 drivers crash, bang and zoom their cars in 3,000 demolition derbies from coast to coast.

The derbies range from 10-car crash-ups to mega events such as the annual Metal Mayhem in Oregon, Ill., where 5,000 fans

watch 200 cars compete for \$15,000 in prize money. The more unusual derbies feature colliding school buses, motorcycles or farm machinery.

Demolition derby's roots

Many consider the now-closed Islip Speedway in Long Island, N.Y., to be the birthplace of organized demolition derbies. In the late 1950s, Larry Mendelsohn, a 28-year-old stock car driver, observed that the crashes drew the most cheers and organized an event billed as "a night full of car wrecks."

"Larry is one of the most overlooked guys in motor sports," says Marty Himes, owner of The Himes Museum of Motor Racing Nostalgia in Bay Shore, N.Y. "He was a genius. Just look at the legacy he left."

By the 1960s, demo derbies—and the Islip Speedway—were regularly featured on ABC's *Wide World of Sports*.

"The first time I saw a derby on TV, I couldn't believe it," Russ Schutte says. "It was the coolest thing I'd ever seen. When a derby came to the (Green County) fairgrounds, I entered a junker. I was a one-hit wonder. One hit and I was done."

That was 1968, and Russ was hooked.

"It's everything a gearhead could love," Russ says. "You get to build a car, smash it, then build it again."



Russ gets a good-luck kiss from his wife Cindy.

(Continued on page 8)

Combined offers valid 6/18-6/28.

DELL

Get an outstanding deal on a new Dell! Save up to \$400 on select Dell™ PCs!

Dell recommends Windows®
XP Media Center Edition



15.4" Widescreen
XGA Display

SAVINGS SPOTLIGHT

Inspiron™ B130 Notebook

Basic Features, Affordable Widescreen

- Intel® Centrino® Mobile Technology
 - Intel® Pentium® M Processor 745 (1.80GHz)
 - Intel® PRO/Wireless 2915 Internal Wireless (802.11a/b/g)
- Genuine Windows® XP Home Edition
- 1GB Shared* DDR SDRAM
- 60GB* Hard Drive
- CD/DVD Burner (DVD+/-RW*)
- 1-Year Limited Warranty*, Ma2-In Service, Hardware Warranty Support

Pre-Savings **\$938** Now Only **\$599** after \$339 off or as low as \$18/mo.  E-Value™ Code: 07745-D80609H

UPGRADE IT!

\$205

- 80GB* Hard Drive
- Microsoft® Works Suite 2006 – Includes Word
- Additional 6-Cell Lithium Ion High-Capacity Battery
-  E-Value Code: 07745-D80611C

PROTECT IT LONGER!

- 3-Year Limited Warranty*, At-Home Service*, Hardware Warranty Support \$210
- 15-Month Subscription to McAfee® SecurityCenter™ with VirusScan®, Firewall, Privacy and Spyware Removal \$79

Introducing **DellConnect**

The simple online access tool that can allow a Dell service and support associate to diagnose your PC problems and help solve them remotely using a broadband connection. Don't bring your PC to the shop. Bring the shop to your PC. Go online for details at www.dell.com/dellconnects.

- Dell™ Photo All-in-One Printer 944 \$129
- 10' USB Printer Cable \$25
- 3-5 Day Shipping on all Dell printers at **NO CHARGE!**

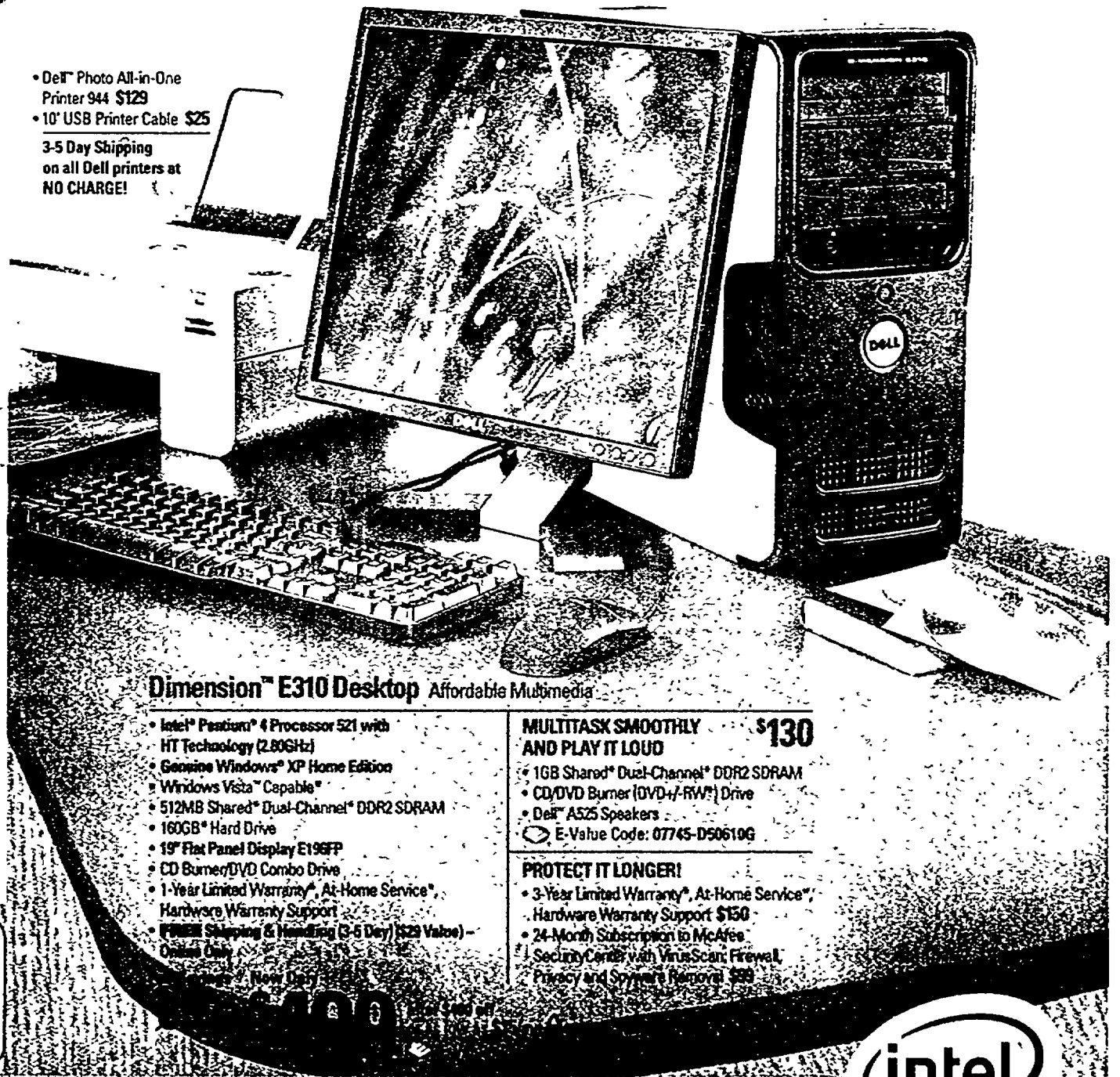

Dimension™ E310 Desktop Affordable Multimedia

- Intel® Pentium® 4 Processor 521 with HT Technology (2.80GHz)
- Genuine Windows® XP Home Edition
- Windows Vista™ Capable*
- 512MB Shared* Dual-Channel* DDR2 SDRAM
- 160GB* Hard Drive
- 19" Flat Panel Display E196FP
- CD Burner/DVD Combo Drive
- 1-Year Limited Warranty*, At-Home Service*, Hardware Warranty Support
- **FREE! Shipping & Handling (3-5 Day) (\$29 Value)** – Online Only

MULTITASK SMOOTHLY AND PLAY IT LOUD **\$130**

- 1GB Shared* Dual-Channel* DDR2 SDRAM
- CD/DVD Burner (DVD+/-RW*) Drive
- Dell™ A525 Speakers
-  E-Value Code: 07745-D50610G

PROTECT IT LONGER!

- 3-Year Limited Warranty*, At-Home Service*, Hardware Warranty Support \$150
- 24-Month Subscription to McAfee® SecurityCenter™ with VirusScan®, Firewall, Privacy and Spyware Removal \$99

Priced for everyone. Built just for you.

1-800-283-1450

Shop by phone 7 a.m.-11 p.m. CT
For hearing/speech impaired: 1-877-DELL-TTY (toll-free)

www.dell.com/profile

Click anytime for deals you can't find in retail stores!

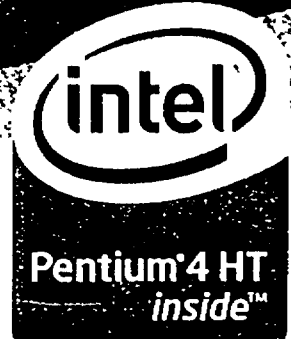

DELL PREFERRED ACCOUNT (DPA): Offered by CIT Bank to qualified U.S. residents with approved credit. Creditworthiness determined by lender. Taxes, fees, shipping, handling, and any other applicable charges are extra, and vary. Monthly payments based upon pre- rebate price. Minimum monthly payments of \$15 or 3% of account balance, whichever is greater.

PRICING/AVAILABILITY: Prices, specifications, availability and terms of offers may change without notice. Taxes, fees, shipping, handling (except systems free 3-5 day shipping & handling offer, if applicable) and any applicable restocking charges are extra, and vary. Offers may be combined with other select offers or discounts. Valid for U.S. Dell Home Systems Co. new purchases only. Systems free 3-5 day shipping and handling offer is available in Continental (except Alaska) U.S. only. Dell cannot be responsible for pricing or other errors, and reserves the right to cancel orders arising from such errors. **LIMITED WARRANTY:** You can get a copy of our limited warranties and guarantees by writing Dell USA LP, Attn: Warranties, One Dell Way Round Rock, TX 78682. To purchase warranty only or for information on other service options please call 1-800-915-3355 or visit www.dell.com/termsandconditions. **AT-HOME SERVICE:** At-Home service provided via third-party contract with customer. Technician will be dispatched if necessary following phone-based troubleshooting often the next business day. Availability varies. Other conditions apply. **HARD DRIVE:** For hard drives, GB means 1 billion bytes, actual capacity varies with preloaded material and operating environment and will be less. On Dimension, XPS, and Inspiron systems for Norton Ghost 10 and Dell DataSafe users, up to 25% of the stated hard drive capacity may be utilized by your system as dedicated backup space. **SHARED SDRAM:** Up to 128 MB of system memory may be allocated to support graphics, depending on system memory size and other factors. **McAfee SECURITYCENTER:** This offer is only available when purchased at point of sale and is not available after you receive your system. **WINDOWS VISTA CAPABLE:** Based on currently available information from Microsoft. Requirements subject to change. Microsoft requires that a PC have a modern processor and 512MB RAM to be included in the Windows Vista Capable PC program. Since the operating system and drivers are not final, Windows Vista has not been tested on all user configurations. Please visit www.dell.com/vista for more information. **DUAL CHANNEL MEMORY:** Dual-channel memory requires 2 each of the same capacity memory DIMMs. **DVD+RW, DVD+RW/-R AND DVD+/-RW DRIVES:** Discs burned with this drive may not be compatible with some existing drives and players, using DVD+R media provides maximum compatibility. **TRADEMARKS/COPYRIGHT NOTICES:** Intel, Intel logo, Intel Inside, Intel Inside logo, Celeron, Celeron Inside, Centrino, the Centrino logo, Intel Core, Core Inside, Pentium, and Pentium Inside are trademarks or registered trademarks of Intel Corporation or its subsidiaries in the United States and other countries. Microsoft and Windows are registered trademarks of Microsoft Corporation. ©2006 Dell Inc. All rights reserved.

(Continued from page 6)

Through the years, 12 of Russ' 16 brothers and sisters, who range in age from 32 to 60—and a few of their children—have driven in an estimated 300 demo derbies and won trophies and cash prizes in more than 100 events throughout the upper Midwest.

In 2000, a love for the sport prompted Tory to form the Demolition Derby Drivers Association, a 5,500-member group that supports standardized track rules across the country. The association's website, www.wcrash.com, features an events calendar, classified ads with 600 demo cars for sale, and car-building tips and techniques.

"We don't charge for memberships in the association," says Tory, a Navy recruiter. "I just wanted to give something back to the drivers. I want people to love the sport as much as I do."

Family tradition

Last September, Tory drove 1,600 miles in three days from his home in El Paso, Texas, to spend a weekend building, and then smashing, the 1976 Chevy station wagon that he hauled on a trailer to Russ' house in Wisconsin.

For two days before the derby, a dozen Schutte family members and friends put

the finishing touches on Russ' and Tory's cars. The occasional white flash of arc welding, the sound of sledgehammers on steel, and the smell of fresh spray paint filled Russ' garage, which primarily serves as a 32-by-42-foot demo derby car workshop.

The self-taught mechanics welded and hammered bumpers to the frame and painted Tory's station wagon Green Bay Packer green. Russ' wife, Cindy, who has attended nearly every demo event with her husband since the mid-1970s, packed lunches—and aspirin—for the four-hour round trip to Iowa.

"That is what it's all about," Russ says. "Spending time together as a family. I guess it's what they call bonding. With 17 kids in the family, we didn't get to do a lot of that growing up. This workshop is like our sandbox."

Tory drove his wreck to a third-place finish.



Russ relaxes in his demolished Chevrolet, bound for his garage in Monroe, Wis.

The Schuttes number their demo cars based on birth order. Russ, the fourth oldest, drives the No. 4 car. Youngest sibling and regular derby driver Ryan, 32, drives the No. 17 car.

Russ' daughter, Vicki, 24, is one of the rare female drivers—an estimated 2 percent—in the world of demo derbies. She's driven in a dozen derbies since winning a women-only event in 2001.

"It's something I can relate to the guys in the family with," says Vicki who, as Russ' oldest child, drives the '4a' car. "It's one time I know we can all hang out together. And when I drive, there's something pretty powerful in taking out my road rage on someone else."

Track rules

The requirements for demo cars are simple: Remove the windows, move the battery to the passenger side floor and replace the original gas tank with a small tank in the back seat.

Attention to detail, though, is what separates one-hit wonders from winners.

"A car shifts a lot when you hit it at 30 miles per hour," Russ says. "We strip the cars down to the frame, then completely rebuild them. We put in motors that can take a lot of abuse. We put a lot of time into protecting the wires and distributor cap and the radiator and hoses. We can spend an entire night welding one bumper."

The average Schutte car costs from \$500 to \$3,000. They spend an estimated 100 man-hours preparing each car for derby competition.

"I don't golf," says Russ, who operates heavy machinery for a fertilizer company. "Those golfers spend a lot of money on greens fees."

Rate This Story

How did you like this story? Log on to www.americanprofile.com/rate

"And," Tory asks, "do they get to feel like human gladiators?"

Demolition derby rules are simple: Don't hit a driver's side door. Sandbaggers—drivers who spend more time avoiding crashes than causing them—get disqualified. The last car moving wins.

Derby night

During the final event in Davenport, Russ and Tory never got a chance to go head to head on the track. Just a few minutes after the starter's flag dropped, Russ' rear bumper got hooked to another car and, vulnerable, his Chevy Impala took a direct hit that bent the car's front end straight up in the air.

"The distributor cap exploded," Russ says, "and every piece of metal in the car became an electrical conductor. It was, for me, a shocking experience. At least until I turned the engine off." He finished 12th.

Tory landed a number of solid hits with his station wagon and knocked out three cars. He finally got wedged into a corner—against one of the concrete barricades that surround the track—and couldn't work his way out. He took home \$300 and a 3-foot-high, third-place trophy that eventually will make its way to the family's collection displayed on Russ' living room table.

Long after the last fans exited the grandstands, Russ winched his car, with the front bumper sticking up higher than the car's roof, onto his flat bed trailer. "It doesn't look too bad," Russ says. "If we can't straighten the body out, we'll just buy another car and start all over again."

"It's really just a good excuse to spend some time with family and friends. And then spend another Saturday night wrecking some cars." ☆

Steve Lange is a freelance writer in Rochester, Minn.

ATTENTION DIABETIC METER RECALL ALERT

So far in 2006 there have been 12 manufacturer notifications. There have been over 20 different Class I High Risk Recalls for diabetic meters issued by the U.S. Food and Drug Administration in 2005. A Class I recall means that there is a reasonable chance that the product will cause serious health problems or death. Most major diabetic meter manufacturers have had a recall in the past 2 years! **YOUR CURRENT METER MAY BE INVOLVED IN A RECALL.**

Accuracy and consistency are extremely important when you test your blood!

If you have Medicare call us now to get a **NO COST** to you replacement meter and new testing supplies! Sorry, we are unable to help you if you are in an HMO.

Call Discount Diabetic at 1-800-853-6127.

If you have Arthritis, Medicare will cover a large, moist heating pad for you at **NO COST** to you. *Deductible and copay may apply.

Call 1-800-853-6127

Take it in your
hands and grasp
nature's majesty.

WOODLAND MONARCH

On a crisp morning you catch a glimpse of brown in the trees. Suddenly a ten-point buck emerges from the woods and turns toward you bearing all the nobility of the wild, providing the crowning image of nature's majesty.

A HAND-CRAFTED SCULPTURAL TREASURE

Now experience it for yourself in a replica collectible knife that measures a full 10 inches in length and features art from Greg Alexander on its porcelain blade. Beautifully detailed sculptures of a doe and buck adorn the hand-painted handle.

STRICTLY LIMITED EDITION... ORDER TODAY!

Strong demand is expected, so act now to acquire your replica knife at the \$39.95* issue price, payable in two installments of \$19.97 each. Your purchase is backed by our 365-day money-back guarantee. Send no money now. Just mail the Reservation Application today!

©2006 BGE 01-02544-001-EI

collectiblestoday.com

Home of The Bradford Exchange and All Things Collectible

RESERVATION APPLICATION

THE BRADFORD EXCHANGE

9345 Milwaukee Avenue Niles, IL 60714-1393

THE *Heart* OF COLLECTING

YES. Please reserve the "Woodland Monarch" collectible for me as described in this announcement.
Limit one per order.

Please Respond Promptly

Signature _____

Mr. Mrs. Ms _____
(Name, Please Print Clearly)

Address _____

City _____

State _____ Zip _____

01-02544-001-E57191

*Plus a total of \$5.99 shipping and service. Illinois residents add state sales tax. Prices higher in Canada. A limited edition presentation restricted to 295 casting days. Allow 4-8 weeks after initial payment for shipment. All sales are subject to product availability and order acceptance.

Replica knife
is richly
adorned with
deer and leaf
sculpture and
full-color
artwork

Shown smaller
than actual
height of
10½ inches.

Hometown Spotlight

On the morning of the Fourth of July in Fishkill, N.Y. (pop. 1,750), residents Jim Pagonos and his wife, Joan, stand atop the steps of the community hall—Van Wyck Hall—to carry on the 104-year-old Fishkill tradition of reading aloud the Declaration of Independence. The event draws hundreds of patriotic spectators from the state's mid-Hudson Valley region who gather on the street and sidewalk to hear the words crafted by America's founding fathers in 1776.

"I feel honored," says Joan, 58, a town supervisor. "It's such a thrill and a privilege, and the children who are here today will carry on this tradition to the next generation."

"The Declaration of Independence is as alive today as the day (Thomas) Jefferson wrote it," adds Jim, 55, a Dutchess County surrogate court judge.

Before the reading takes place, the crowd sings a rousing version of "The Star-Spangled Banner" and the bell at the 1731 Dutch Reformed Church tolls once for each year since 1776. Last year, Toni Houston and Roy Carruthers, who regularly ring the bell for Sunday morning services, pulled the bell's rope 229 times.

The church is an appropriate part of the Fourth of July celebration. During the American Revolution in the fall of 1776, the New York Provincial Congress met there to conduct business and write a constitution for the new State of New York. Among the delegates were Hudson Valley natives Robert Livingston, who helped draft the Declaration of Independence; his cousin Philip Livingston, who signed it; and John Jay, who became the first Chief Justice of the U.S. Supreme Court.

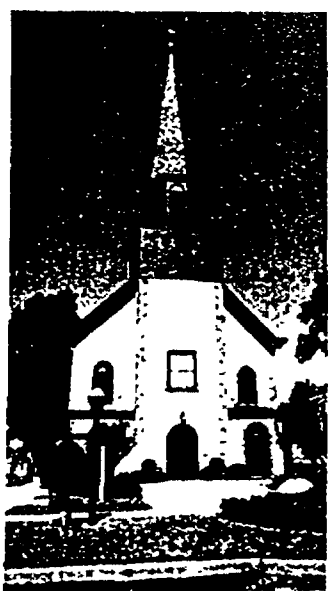

The Dutch Reformed Church

The annual reading began in memory of Henry DuBois Van Wyck, a native son who ventured west, made a fortune in the California gold rush and returned home. Van Wyck served as the first mayor when Fishkill was incorporated in 1899. He also built Van Wyck Hall as a working theater with the intention of giving it to the town, but died before his wishes could be carried out. Later, his heirs fulfilled that

Declaring America's Independence

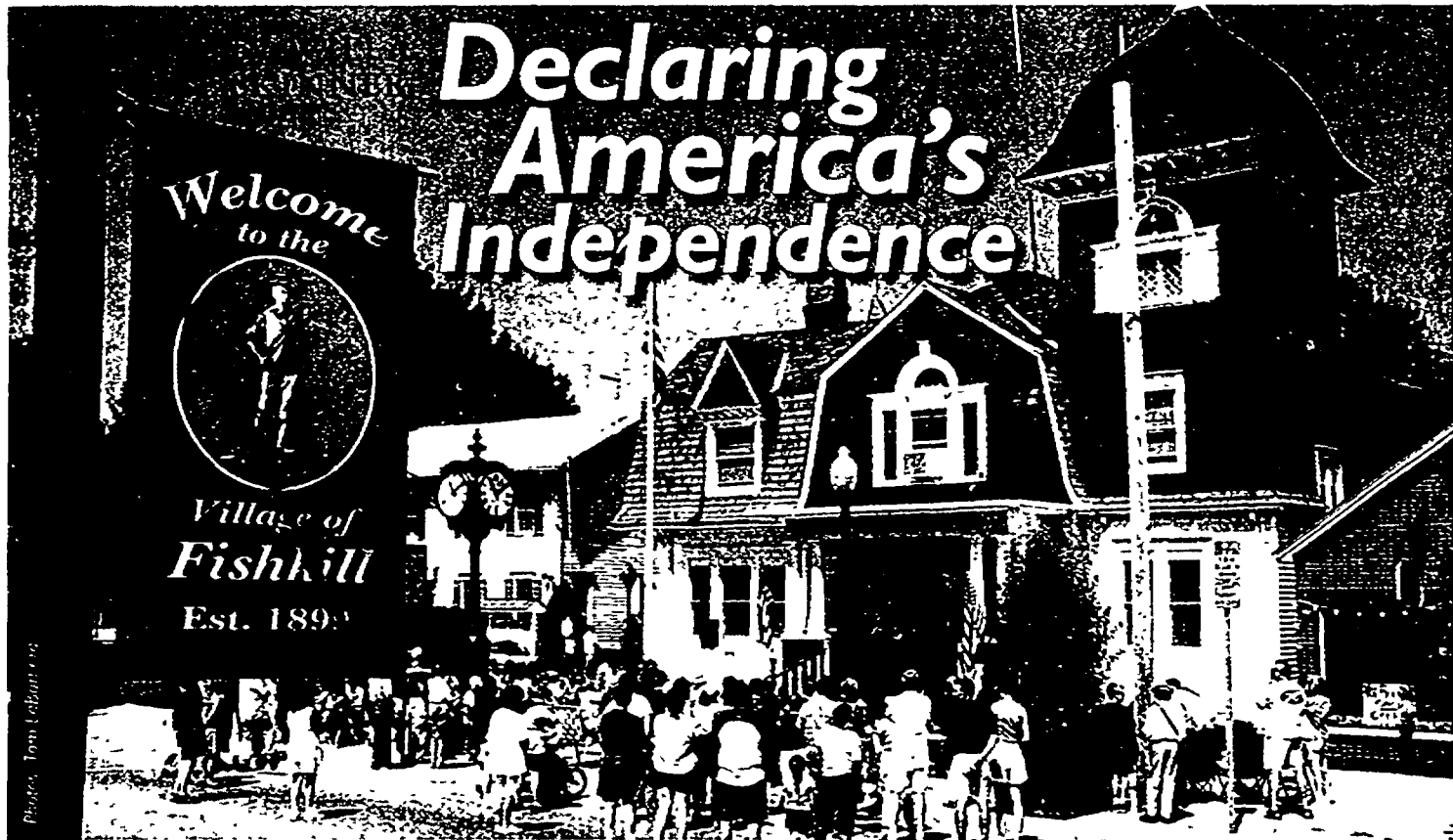

A crowd gathers outside Van Wyck Hall in Fishkill, N.Y., awaiting the annual Fourth of July reading of the Declaration of Independence.

wish and made an informal request that the Declaration of Independence be read aloud at the hall to honor their uncle's memory and his love of country.

"There is nothing in writing that says this should be done," says Fishkill historian Karen Hitt. "It's just a custom that has continued unbroken since the first reading in 1902."



Joan Pagonos and Jim Miccio

The custom, however, hasn't always had such a great turnout. There was a time in the 1950s when two residents, businesswoman Mary Bogardus and Sarah Taylor, who served as mayor from 1965 to 1975, found themselves alone at Van Wyck Hall on a dreary, rainy July Fourth. Undaunted, they stood outside on the steps and recited the Declaration just to keep the tradition alive, with no one but Taylor's dog for an audience. In succeeding years, Bogardus served as the reader and helped spread the word as new families moved to the area.

Since Bogardus' death in 1983, people from all walks of life—teachers, homemakers, a Gulf War veteran and historians—have been chosen to read the Declaration. There is no set policy on choosing each year's new reader, according to Hitt, who arranges the annual festivities with a committee and the Fishkill Historical Society.

Once the Pagonoses conclude their 20-minute reading, spectators file inside Van Wyck Hall to sign a guest book and celebrate the nation's birthday with slices of red, white and blue birthday cake donated by local merchants.

"It's not the fanciest celebration," Mayor Jim Miccio says. "But it's one of the best. It lets us know the meaning of why we celebrate." ★

Willie Skinner is a freelance writer in Fishkill, N.Y.

For more information, call the village of Fishkill at (845) 897-4430.

Rate This Story
How did you like this story? Log on to www.americanprofile.com/rate

Special Offer + FREE Flag Cards AMERICA'S FAVORITE FLAG SET

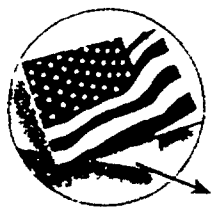

Fly Old Glory proudly this season! Set includes a 3-foot-by-5-foot American flag made from heavy cotton sheeting, brass grommets, 6-foot aluminum pole, gold plastic eagle, steel bracket/screws and assembly instructions. Made and assembled in the USA by American labor! PLUS - order now and receive a FREE 5-pack of patriotic notecards and envelopes.

To order the flag kit plus FREE flag notecards for \$24.95 + delivery, go to www.americanprofile.com/store or please have your credit card ready and call (800) 715-6248 or send check for \$29.90 to USA Flag Offer—Dept. AP, P.O. Box 340, Harrison, AR 72602.

CA, TN, IL, AR, NY residents add state sales tax. NSF checks automatically debited for amount of check + applicable fees. Expires 8/25/06. Allow 2-4 weeks for delivery. Satisfaction guaranteed or we will refund purchase price less s&h.



AS FEATURED ON TV

Bone-Health Breakthrough!



Can't Take FOSAMAX[®] or Boniva[®]? Don't be discouraged...

If your doctor told you not to take FOSAMAX[®] or Boniva[®] because of possible side effects, don't be discouraged... Ask your doctor about



*OsteoValin[™] is not a drug. OsteoValin is a Dietary Supplement and is not intended to be used as a substitute for any disease treatment, including drugs used for the treatment of osteoporosis.

NEW! OSTEOVALIN

- All-New
- All-Natural
- Non-Prescription
- Non-Drug Bone-Health Breakthrough

We all need strong bones... it's the difference between living young and being old. But calcium alone is not enough. And many of us can't take prescription drugs because of adverse side effects.

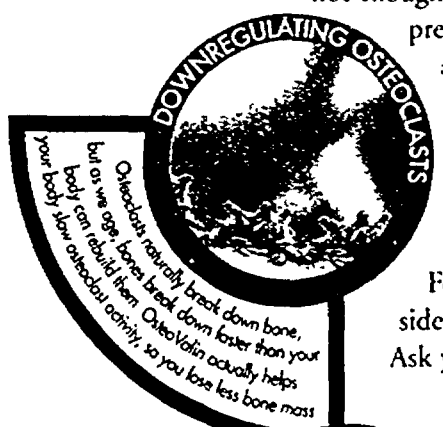

But now there's OsteoValin... the all new, all natural, non-prescription bone-health breakthrough.

If your doctor told you not to take Fosamax or Boniva because of possible side effects ... don't be discouraged. Ask your doctor about OsteoValin.

OsteoValin not only helps prevent bone deterioration, it actually helps your body build new bone mass*...

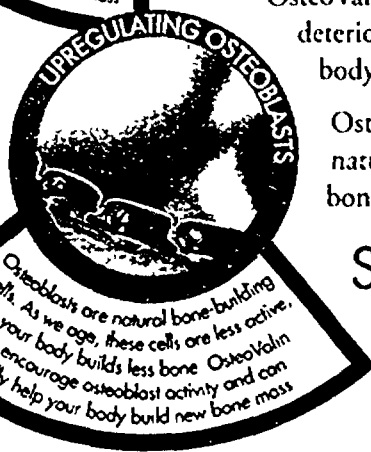

OsteoValin... the all new, all natural, non-prescription bone-health breakthrough!

Stay strong, upright and active...

Free Shipping Call Now!

1-800-391-0615

www.OsteoValin.com

While not conclusive, scientific evidence suggests that OsteoValin may help the body reduce bone deterioration and build new bone mass through natural down-regulation of osteoclast production and upregulation of osteoblast activity.

These statements have not been evaluated by the Food and Drug Administration. This product is not intended to diagnose, treat, cure, or prevent any disease.

*Fosamax is a registered trademark of Merck & Co., Inc.
Boniva is a registered trademark of Roche Therapeutics Inc.
All trademarks are the property of their respective owners.

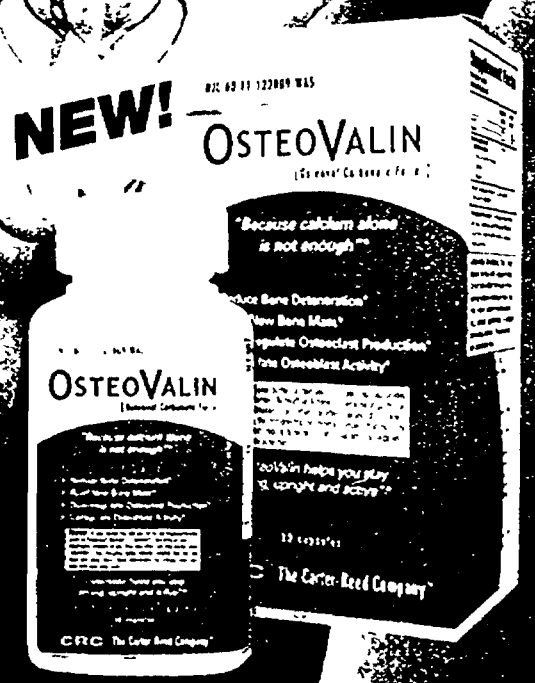
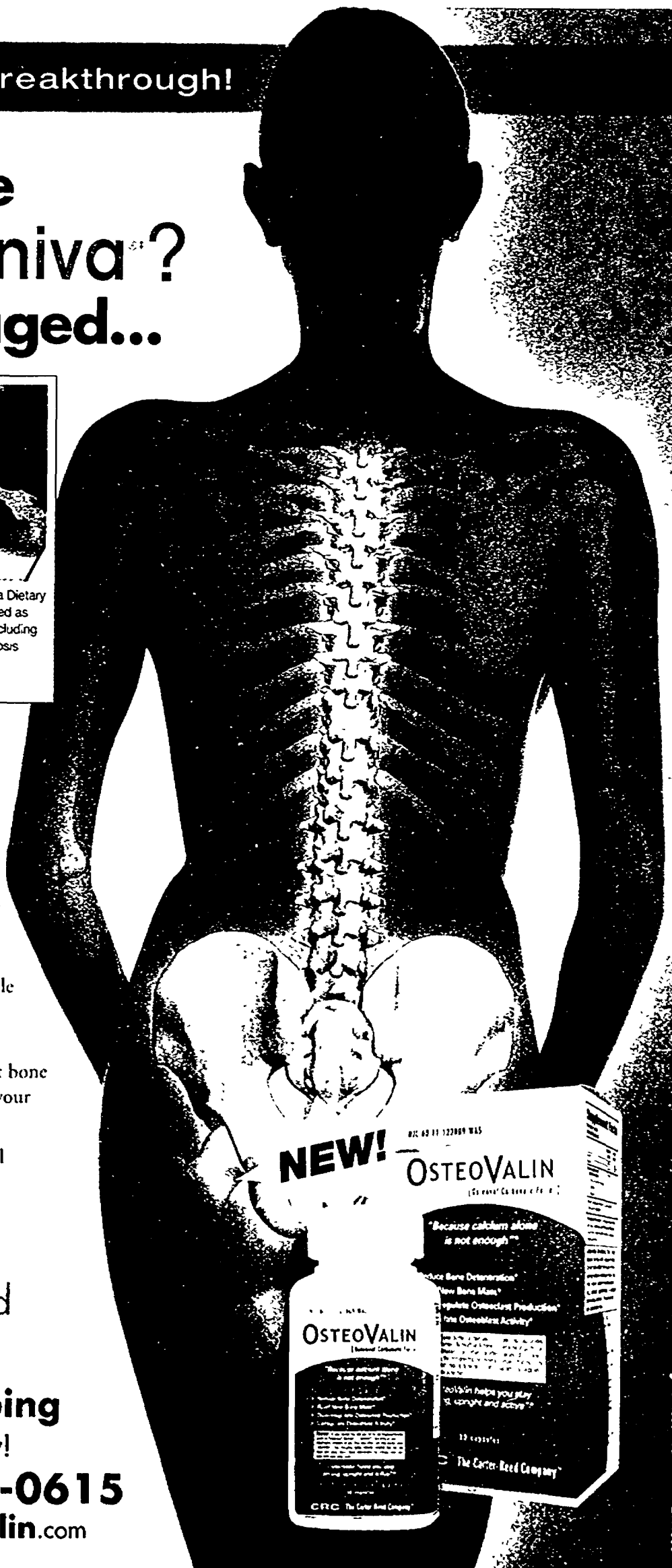

Win a FREE Copy of the *American Profile* NEW Holiday Cookbook!

WE'RE LOOKING FOR THE
BEST HOLIDAY RECIPES IN AMERICA!

Whether it's New Year's Day, Valentine's Day, Passover, Easter, 4th of July, Thanksgiving, Christmas, or any other holiday you celebrate, we want your special recipe!

If your recipe is chosen and published in the cookbook, you will receive a **FREE** copy when it's published in 2007.

Send us your recipe along with a color photograph of yourself and your name, address and phone number in case we have a question. Also, please send us a brief description of the recipe and how you celebrate the holiday. PLEASE note the holiday on the bottom left hand corner of the front of the envelope.

Deadline for submissions: August 1, 2006. *One recipe per envelope, please.*

Please send your recipe to:

Holiday Cookbook, 341 Cool Springs Blvd., Suite 400, Franklin, TN 37067

All submissions and photos become the property of American Profile. (Sorry, we can't return any materials.)



Tidbits

Did You Know...

ILLINOIS—The famous question—"Will it play in Peoria?"—originated during the 1920s vaudeville era when new stage shows were booked in Peoria to test audience reaction. Peoria was considered a typical heart-of-America town.

INDIANA—One of the nation's oldest football "trophies" is the Old Oaken Bucket, awarded since 1925 in the annual game between Purdue University in West Lafayette (pop. 28,778) and Indiana University in Bloomington. The century-old bucket, covered in moss and in need of repair, was found on a southern Indiana farm and designated a suitable trophy for the winner of the in-state rivalry.

IOWA—Built in 1886, St. Anthony of Padua Chapel near Festina in Winneshiek County (pop. 21,310) offers a little piece of heaven to visitors. The chapel measures only 14 feet by 20 feet, seats eight and is among the smallest in America.

KANSAS—After restoring more than 50 antique pump organs, Dick Rhea orchestrated them into a pump organ museum in downtown Sharon Springs (pop. 835). The organs date from the late 1800s to early 1900s.

MICHIGAN—Sanctuary and Safe Haven for Animals, or SASHA Farm, in Manchester (pop. 4,102) is among the largest farm-animal sanctuaries in the Midwest, offering shelter to more than 200 animals that have been neglected or discarded.

MINNESOTA—Madison (pop. 1,768) is the self-proclaimed "Lutefisk Capital of the World," where the town mascot is a 25-foot-long codfish statue aptly named Lou T. Fisk. Loved or loathed, lutefisk is a traditional Scandinavian dish of dried cod treated with lye. Lutefisk-eating contests are held during Madison's annual Norsefest each November.

MISSOURI—The Butler (pop. 4,209) Public Library is endowed by pioneering science fiction writer Robert Heinlein (1907-1988), who was born in Butler, and his wife, Virginia (1916-2003). The library houses many autographed and first editions of Heinlein's books, including *Strangers in a Strange Land* and *The Moon is a Harsh Mistress*.

NEBRASKA—An obsolete Titan 1 intercontinental ballistic missile stands in a park in Kimball

(pop. 2,559), once known as "Missile Center-U.S.A." because of the hundreds of missile silos built near the town in the late 1950s and early 1960s.

NORTH DAKOTA—A 400-pound, 6-foot-in-diameter bronze replica of the state's Great Seal was unveiled in February in the Capitol's Memorial Hall in Bismarck (pop. 55,532).

OHIO—In 1920, Youngstown candy maker Harry Burt created ice cream on a stick with his Good Humor Bar, so called because it was believed a person's "humor" or temperament was related to the humor of his palate or taste.

SOUTH DAKOTA—Jewel Cave near Custer (pop. 1,860) is the world's second longest cave. Spelunkers spent four days underground in January and explored an additional 3,700 feet, bringing the cave's total explored length to 135 miles and 10 feet.

WISCONSIN—In the winter, volunteers in Junction City (pop. 440) saw blocks of ice from frozen ponds and store them in a metal icehouse. During the summer, the ice is sold to benefit community projects. ☆



50 Glorious HYMNS

Residents of CA, TN, IL, AR and NY add sales tax. NSF checks will be automatically debited for the amount of the check plus applicable fees. Offer is limited and expires 1/31/06. Please allow 2-4 weeks for delivery.

HEAR CLASSIC HYMNS LIKE:

*How Great Thou Art • I'd Rather Have Jesus
Blessed Assurance • And Can It Be?
In the Garden • Turn Your Eyes Upon Jesus*

2 CD SET

Go to www.americanprofile.com/store
or call (800) 715-6248 from 8am - 5pm CDT, M-F or send check or money order for \$29.94 (\$25.99 + \$3.95 s/h) to Hymns - Dept AP, P.O. Box 340, Harrison, AR 72602.

FREE PERSONALIZATION

Grandmom's Precious Jewels

P E N D A N T

There's always room on her lap...and in her heart...for one more grandchild. That's why a grandma's love is so special.

Now she can show her love with an original birthstone pendant from Lenox. Crafted of solid sterling silver, this open-heart pendant has "Grandmom" spelled out in 24 karat gold electroplate. Her birthstone glistens in the center. And one birthstone for each of her precious grandchildren (up to 10) sparkles within the heart.

Genuine gemstones

Each birthstone is a genuine gem. Diamond, sapphire, ruby, emerald...each as brilliant as grandma's love. And they can be arranged within the pendant in the order she wishes (see the Order Form).



Pendant and gems shown actual size. Each birthstone is a genuine gem, individually hand set.

Grandmom's Precious Jewels Pendant is available direct from Lenox at \$95, payable in convenient monthly installments. A Certificate of Authenticity and 20-inch sterling silver chain accompany the pendant.

Order this imported Lenox® pendant today—for yourself or as meaningful gift. Lenox guarantees your complete satisfaction.

JAN/Garnet



JUL/Ruby



FEB/Amethyst



AUG/Peridot



MAR/Aquamarine



SEP/Sapphire



APR/Diamond
(illusion setting)



OCT/Cabochon
Opal



MAY/Emerald



NOV/Topaz



JUN/Cultured Pearl



DEC/Cabochon
Turquoise



Birthstones shown larger than actual size.

LENOX

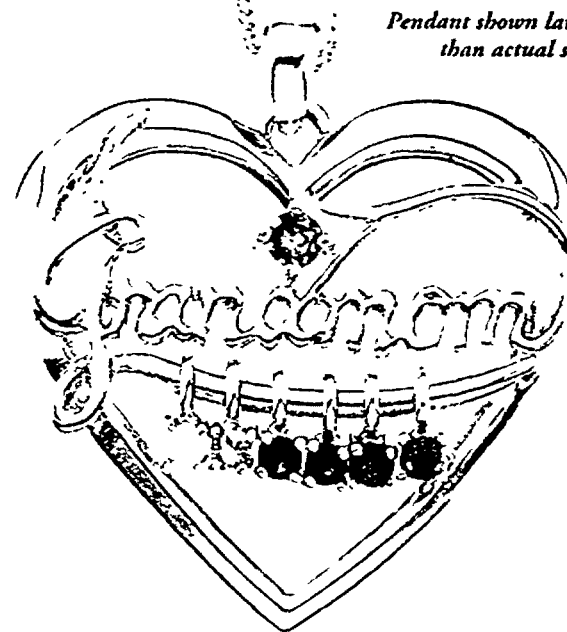

Pendant shown larger than actual size.

A heart of sterling silver and gold
personalized with your
and your grandchildren's birthstones

Order Form • Please mail within 30 days

Solid sterling silver • 24 karat gold • Genuine gems

I wish to order *Grandmom's Precious Jewels Pendant*, set with birthstones for the months indicated. No payment is required now.

Bill me for my pendant in five monthly installments of \$19* each.

Personalization instructions: Print the three-letter month abbreviations in the spaces below. Grandchildren's birthstone gems will be placed left to right, bottom (nos. 1-7) to top (nos. 8-10).

Grandma's birth month:

Grandchildren's birth months: (limit ten)

1. 2. 3. 4. 5.

6. 7. 8. 9. 10.

Signature _____

ALL ORDERS ARE SUBJECT TO ACCEPTANCE

Name _____

PLEASE PRINT CLEARLY

Address _____

City _____

State _____

Zip _____

S4019741

Telephone (____) _____

E-mail _____

* Plus \$6.50 per pendant for shipping and processing. Your sales tax will be added.

Mail to: Lenox

P.O. Box 3020 • Langhorne, PA 19047-9120



ClearPoint Direct.Com
P.O. Box 3508 Champlain NY 12919

UG60666
(Please print)

Name: _____
Address: _____ Apt: _____
City: _____ State: _____
Zip: _____ Tel: (____) _____

Item #	Description	Price	Qty	Total
(#0231)	Listening Device	\$9.95/each		
(#0470)	Shake-A-Light	\$5.95/each		
S & H - no matter how many are ordered				\$3.95
No C.O.D				Total for Order

SIGNATURE X

I have been advised by ClearPoint Direct that the Food and Drug Administration (FDA) has determined that my best health interest would be served if I had a medical evaluation by a licensed physician who specializes in diseases of the ear before purchasing a hearing aid. I do not wish a medical evaluation before purchasing a hearing aid.

Enclosed is \$_____ made payable to **ClearPoint**
Money Back Guarantee: Return merchandise within 90 days for refund less Shipping & Handling if not entirely satisfied.

Hear What You're Missing

Discreet Listening Device™

Brings Everything In Close

Great for:
Watching TV, Conversations,
Church Services & Nature Walks



Compact & Powerful
Loaded With Features!

- Low Profile Design, Hardly Noticeable
- Advanced Miniaturized Circuitry
- Fully Adjustable Volume Control
- Easy One Touch On-Off Switch
- Fits Securely & Discreetly Into Ear
- Easy to Read Instruction Booklet
- Save Thousands of Dollars
- Full Money Back Guarantee

Only
\$9.95
each
Sold
Elsewhere
for \$19.95



**For Right
or
Left Ear**

With the Discreet Listening Device™, you get on the inside track. Secretly listen to private conversations. Pick-up on the latest office gossip and hear what people are saying. Small enough to fit discreetly inside the ear. It is practically undetectable. Advanced circuitry and powerful amplifier brings you closer to the action. Great for nature walks, church services, the theatre, listening to TV, conversations, and much much more...

www.clearpointdirect.com

Shake-A-Light

ONLY
\$5.95
each

Can be Charged Thousands Of Times

Ultra-bright LED
Emergency Flashlight
Guaranteed to Last
FOREVER!

NEVER
Needs
Batteries

- Just Shake For 30 Seconds & Go
- High Intensity LED Light NEVER Needs Replacement
- Magnifying Lens Ensures Brightest Illumination - Visible Up to 1 Mile
- Water & Weather Resistant - It Even Floats
- Made of Highly Durable Impact Resistant Polymer Materials
- Use It Anywhere - Car, Camper, Cottage, Hiking, Boat, Travel or Emergency Kit

This amazing emergency flashlight is guaranteed to provide you with light wherever and whenever you need it - does not need batteries. Practically indestructible this flashlight is a must have for home, auto, cottage or camper - anywhere emergency light is required. High strength magnet passes back and forth between a wire coil, giving power to an ultra white bright LED. Shake for 30 seconds gives all the light you need. LED lasts over 100,000 hours and the flashlight can be recharged an infinite number of times. Made of unbreakable chemical resistant polymer. Makes a thoughtful gift.

Profiles in History

by JACK
KELLY

Grandmother to the Nation

Her name was Anna Mary Robertson Moses, but the nation knew her as Grandma. She didn't start painting until age 77, but she lived to become one of America's most popular artists.

Grandma Moses (1860-1961) left behind an evocative record of rural America in a simpler era. She grew up during the Civil War on a farm in upstate New York, married and raised five children. As a widow and grandmother, she began to paint her memories of farm



life—Thanksgiving dinners, maple sugaring and winter sleigh rides. In 1939, an art collector discovered her paintings in a drugstore window. Before long, the notion of the "painting grandma" captured the public's imagination, and her images were appearing on greeting cards, lamps, drapes and many other household products. She painted more than 1,600 works before her death at 101.

To learn more about this captivating and spirited lady, *American Profile* interviewed Karal Ann Marling, whose new book, *Designs on the Heart: The Homemade Art of Grandma Moses*, provides a portrait of the painter in the context of her time.

AP: Why take a fresh look at Grandma Moses in the 21st century?

KAM: Some critics have done her the disservice of shunting her into the category of "primitive" artist or pop culture icon. But Grandma Moses first became popular in the 1940s and 1950s because her work represented the values our soldiers were fighting for and offered reassurance during the anxious period of the Cold War. Today, we are again looking for order in an increasingly disordered world. Grandma Moses and her work evoke some of the bedrock American values: independence, self-confidence, family, simplicity and tradition.

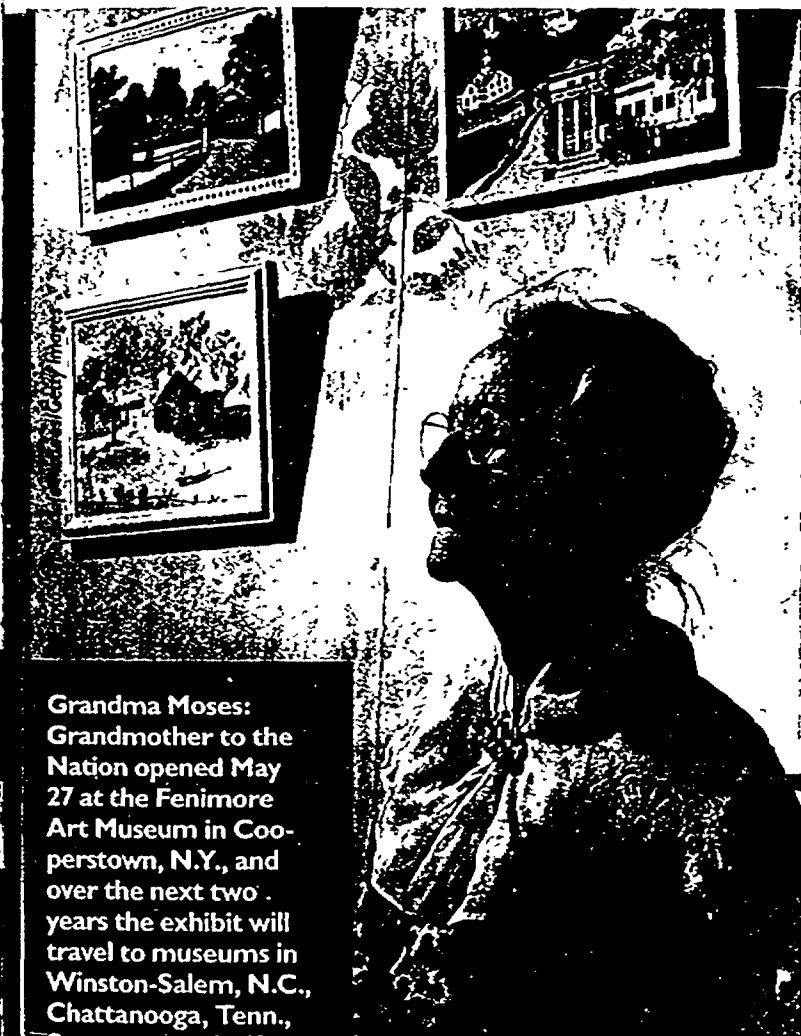

Grandma Moses: Grandmother to the Nation opened May 27 at the Fenimore Art Museum in Cooperstown, N.Y., and over the next two years the exhibit will travel to museums in Winston-Salem, N.C., Chattanooga, Tenn., Sacramento, Calif., and Sarasota, Fla. Visit www.fenimoreartmuseum.org/exhibitions/amoses.htm for more information.

Self-taught artist Grandma Moses in 1947

AP: What did you learn about her that surprised you?

KAM: Her character. I had known about her work, but I didn't understand what a gallant soul she was. Here

was a woman who went to work at age 12, who toiled hard all her life, who made the most of the little schooling she had, who sewed her own clothes and who was still active at 101—she was a truly admirable person. Her attitude toward money is especially refreshing today. Having come out a rural economy where cash didn't mean much, she never paid it much mind. She would deprecate the monetary value of her paintings; she was proud of them simply as paintings.

AP: Does Grandma Moses have something to say to baby boomers?

SPECIAL GRANDMA MOSES BOOK OFFER!

Beautifully illustrated with 68 color artworks, *Designs on the Heart: The Homemade Art of Grandma Moses*, brings to life the story and art of a true American icon. You will learn that while millions were falling in love with the art of this unlikely hero, the New York art establishment openly despised her! (Over 300 pages, 8.4 inches by 9.3 inches.)



To order *Designs on the Heart* for \$35.00 + delivery, visit www.americanprofile.com/store or please have your credit card ready and call (800) 715-6248 or send check for \$39.95 to Grandma Moses Offer—Dept. AP, P.O. Box 340, Harrison, AR 72602.

CA, TN, IL, AR, NY residents add state sales tax. NSF checks automatically debited for amount of check plus applicable fees. Offer expires 8/25/06. Please allow 2-4 weeks for delivery. Satisfaction guaranteed or we will refund your purchase price less s&h.

KAM: Certainly, she could serve as the role model of someone who stayed active all her life. She was always full of curiosity and willing to try something new. She wasn't the type to retire to Florida. Her mantra was work, and she found in work a source of satisfaction and self-respect. Grandma Moses is a poster girl for living well indefinitely through vigorous mental activity, good humor and strong family ties.

AP: What new perspective will the book offer on this familiar artist?

KAM: It gives a sense of how she fit into the culture of her time. Her work is often seen as being timeless. I wanted to show that the enormous popularity Grandma Moses enjoyed resulted from the fact that her art spoke to people of the period in which she

worked. It was a new era of television and rail fins, and though we wanted to gain these things, we didn't want to lose our root values.

AP: You call her "the Nation's Grandma." Why?

KAM: "Grandma" really brought out the fact that her art, her memories, her statements to the press, all were grounded in family. The name was both important and true. It didn't obscure her contribution as an artist. Instead, it put a finger on the essence of what made her special. ☆

Jack Kelly is a writer living in Milan, N.Y.

Rate This Story

How did you like this story? Log on to www.americanprofile.com/rate.

Work at Home Be a Medical Billing Specialist

Earn up to \$40,000 a year*



No previous medical experience needed...learn at home. Prepare medical claims for doctors, hospitals, clinics.

This is an exciting moneymaking opportunity! If you want to make a good living at home—without commuting, without selling...and working the hours you choose—call the toll-free number below or mail the coupon for free facts about what could be the greatest job opportunity of your life! There are plenty of excellent office jobs, too!

COMPARE THESE ADVANTAGES WITH ANY OTHER PROFESSION!

- Earn \$10-\$20/hour and more!
- Choose your own hours...any time of day or night that's convenient
- Save money! No expensive commute, clothes, lunches or day care
- No time wasted traveling to work
- Be your own boss
- Enjoy continuing graduate support throughout your career
- Work in any of the 50 states
- Prestige of working in the medical profession
- Plenty of great office jobs, too

Experts train you step by step...you can be ready to work in as little as four months!

The medical profession needs skilled medical claims and billing specialists...this is a secure, in-demand career! You learn everything you need to know—medical terminology, procedures and how to prepare medical claims for Medicare, Medicaid and private patients. Our experts show you step by step how to do your work to meet the exacting standards of the medical profession.

Compare the money you can make at home as a Medical Claims and Billing Specialist with any other job.

*What other job can you start with as little as four months of training at home and earn up to \$40,000 a year as your experience and skills increase? Plus, working at home, you get these extra benefits—no transportation costs or time wasted going to and from your job, no expensive office clothes or restaurant lunches, no child day care costs, work whatever hours you choose...early mornings, late at night, any time...and take "breaks" whenever you want them. And it's not only the money you make that's important—you'll be working in a prestigious job making a valuable contribution to the medical profession, and really helping people, too.

NATIONALLY ACCREDITED!
GET FREE FACTS!
MAIL COUPON TODAY
OR CALL TOLL-FREE

U.S. Career Institute
2001 Lowe Street, Dept. AMFA66
Fort Collins, CO 80525

1-800-388-8765 Dept. AMFA66

YES! Rush me free facts on how I can train at home to work as a Medical Claims and Billing Specialist.

Name _____ Age _____
Address _____ Apt. _____
City _____ State _____ Zip _____

YES Call me to arrange my **FREE** in-home design consultation.

I want to receive No Payments & No Interest until July 2007* on:

- Custom Cabinet Refacing
- Custom Kitchen Remodeling

I am also interested in:

- Custom Premium Vinyl Siding
- Custom Replacement Windows
- Cooling Systems Heating Systems

Sears

Call for your free in-home design consultation

1-800-276-0299

Hurry! Respond by 08/06/06

No Payments and No Interest until July 2007! with your Sears card*

Please send your request by August 6, 2006 for your FREE in-home design consultation to:
Sears Home Improvement Products, Inc.
PO Box 522290, Longwood, FL 32752-2290

Offer Code: 50-T5-K6-64-AP16

Name _____
Address _____
City _____ State _____ Zip _____
Home Phone () _____
Work Phone () _____
E-mail Address _____
 Yes, I would like to opt-in to receive e-mails with special promotions and information from Sears Home Improvement Products, Inc.

Custom Cabinet Refacing or Kitchen Remodeling



Sears

**No Payments
& No Interest
until July 2007!**

- Hundreds of drawer and door styles to choose from with coordinating hinges and handles
- Large selection of colors and woodgrains
- Countertops and sinks also available, including selections in laminate or in Corian® by Dupont®
- Turn-key kitchen installation includes related plumbing, carpentry and electrical as needed**
- A project coordinator to stay with you every step of the way
- Installation by Sears-Authorized licensed contractors
- Flexible financing†
- Satisfaction guaranteed*

Call for your FREE in-home design consultation. Hurry, offer ends soon! **1-800-276-0299**

*Offer expires 08/06/06. 0% APR financing until July 2007. Offer not valid on prior sales or in combination with any other offer. Not available on countertop only purchases. 0% APR FINANCING DETAILS (when offered): Available for qualified purchases when you use your Sears cards (Sears Commercial One® account excluded) as advertised. No finance charges accrue or are assessed during the 0% APR period. 0% APR offers of 14 months or more require minimum monthly payments as disclosed in the offer. Regular credit terms apply after the 0% APR period. Finance charges and any required minimum payments will continue on existing balances. If you default under your Sears card agreement, the 0% APR will terminate and penalties, including the default rate will apply. SearsCard/Sears Charge Plus/Sears Premier Card: APR is up to 25.99%, but if your account has a variable APR, the APR is up to 30.15% as of 5/13/06 and may vary. Sears Gold MasterCard/Sears Premier Gold MasterCard: APR is up to 26.49% but if your account has a variable APR, the APR is up to 31.99% as of 5/13/06 and may vary. Sears Home Improvement Card: APR is up to 18.90%, but if your account has a variable APR, the APR is up to 30.15% as of 5/13/06 and may vary. Variable will never be lower than 14.40%. Minimum monthly finance charges up to \$1. See your specific account terms and conditions for your applicable rate and additional information. Sears cards are issued by Citibank USA, N.A. Restrictions and exclusions apply. **Ask your sales associate about written limited warranty details. ***Plumbing, electrical and carpentry work only as it relates to the renovation. +See contract for details. The following licenses are held by or on behalf of Sears, Roebuck and Co.: AK (Gen. Contr. - Exc. Res. #675); AR (Contr. #0117740403); AZ (ROC013509, ROC079967, ROC080918, ROC082564); CA (Gen. Contr. #25455-B, HVAC #25455-C20); CT (HVAC #308530); FL (HVAC #CAC057299, Gen. Contr. #CBC015949); GA (Reg. CND03489); HI (Classified Spec. #C-4285 C-68LA); KY (HVAC #M03912); LA (Mech./Spec. Contr. #5526); MA (Home Imp. #103493); MD (MHC #32117 Steven Feldman, HVAC #6528); Nassau County, NY (H1809170000); NV (Contr. #0054530 0005543 - C-1, C-21); OH (#26034) OF (Gen. Contr. #0001051); RI (Gen. Contr. #4667); Rockland County, NY (H-A6-007621-00-00); TX (HVAC Nos. TACL B020401E, 019005E, 002235C, 013523C, 009563C, 009569C); VA (Class A Contr. #2705057009); WA (Gen. Contr. #SEARSR-372NT); WV (Gen. Bldg. Spec. #WV006529). Some services and installation performed by Sears associates. Other services and installation performed by Sears-Authorized licensed contractors, additional Sears license information available upon request. Electrical services not available in NJ. Ask sales associate for details. †Subject to applicant creditworthiness. ©2006 Sears, Roebuck and Co.